

Making it Right

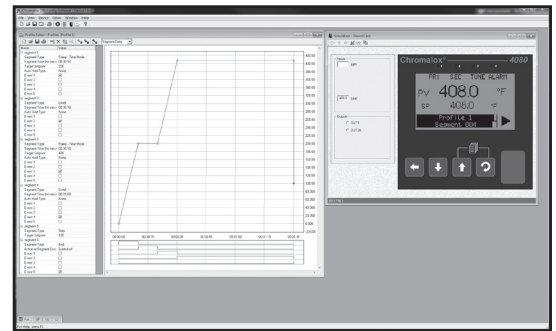

Monitors & Overtemperature Controls

Chromalox makes it easy to protect expensive process equipment, products and processes. From the microprocessor-driven 50 Series High Limit Controller with digital communications, to the space-saving, compact board level models, Chromalox has the right monitor or overtemperature controller for your application.



ChromaloxPro Software

Temperature & Process Controllers

With control options ranging from basic electromechanical thermostats to multi-loop, microprocessor-based temperature and process controllers, Chromalox has the exact degree of cost-effective product sophistication, or simplicity, that your application demands:

- Thermostats
- Non-Indicating Temperature Controls
- 1/32, 1/16, 1/8 and 1/4 DIN Temperature and Process Controllers
- Multi-Loop Controllers
- OEM Engineering and Customization Capabilities

Standard Chromalox controllers are equipped with advanced features such as:

- Digital Communications
- Ramp/Soak
- Fuzzy Logic
- Self-Tuning Control



Cost-Effective Products

SCR Components

SCR technology delivers the high precision power modulation and smooth power output to the load that ensures your process stability. Chromalox delivers, from stock, an entire range of SCR power components that package this technology into easy-to-install, maintenance-free SCR power components:

- Zero-Crossover and Phase-Angle Fired
- 120 to 600 Vac
- 0 to 1600 Amps
- Drive Single and 3-Phase Loads up to 1600 Amps
- Sophisticated Features such as Current Limiting, Flexible Microprocessor-Based Programmable SCR's and LED Status Indicators.

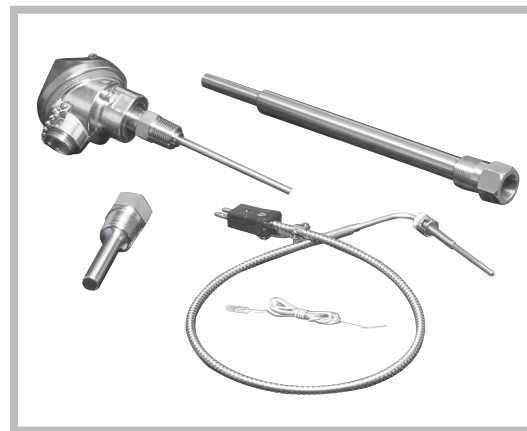
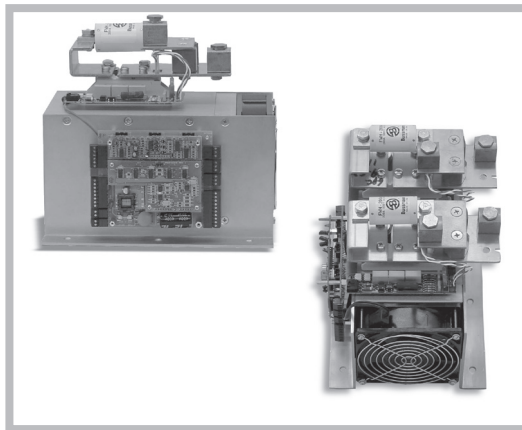

Your Single Source

Heat Trace Controls

Chromalox also offers a complete line of electronic heat trace controls and control panels.



Choose from integrated temperature controls, sensors and single or multi-loop control panels used for process temperature applications and freeze protection. See section G in this catalog for more information about our complete line of heat trace products.

Sensors & Accessories

As your single source for the essential control elements, Chromalox specifies and stocks all the accessories you need to complete your application – simply and reliably from one source:

- Thermocouples and RTDs
- Thermowells, Connection Hardware and Extension Wire
- Non-Contact Sensing Devices
- Calibration Devices
- Indicating Meters, Timers and Recorders
- Electromechanical Contactors, Thermostats and Thermostats.

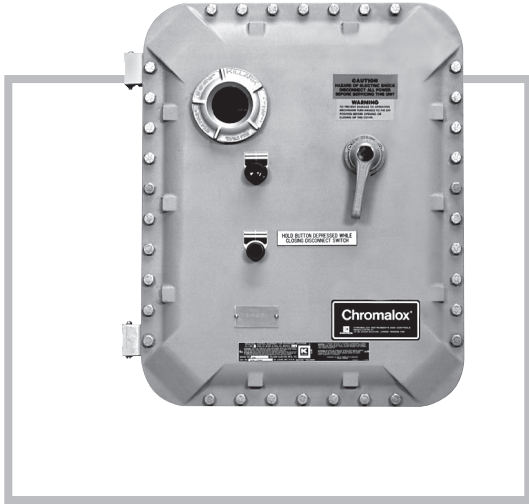

Control Panels

Integrating all the components – temperature controllers, overtemperature controllers and SCRs – into standard, off-the-shelf-panels, sets Chromalox apart from the competition. Chromalox stocks more standard power control panels, in more different sizes and configurations than anyone in the industry. Every panel is pre-engineered, field-proven and ready to install, and saves you the time and trouble of selecting, obtaining and assembling the various components. Select from pre-configured panels that include:

- NEMA 12, 7, 4X or 4 Enclosure
- Process/Temperature Controller(s)
- Overtemperature Controller(s)
- SCR Power Controller(s)
- Contactor(s)
- Control Power Transformer, Firing Card and Fusing
- Pushbuttons, Switches, Indicators and Labeling Options
- Agency Approvals (UL, CSA, cUL)

Power Control Center

Power Control Center™ from Chromalox delivers all the power control and process protection instrumentation that you will ever need – safely, efficiently and with the flexibility and ease-of-use that will make the essential building block of your process control equipment. For all the same reasons you specify a MCC as the industry standard for motor control, you'll quickly find that the Power Control Center™ is an engineered package for power control, designed by power control engineers.

Custom Panels & Control Systems

Drawing on nearly 100 years of experience, Chromalox has an expertise that comes from working with world-scale engineering groups such as Bechtel and Flour-Daniel, U.S. military shipboard systems and the most demanding research institutions. Chromalox has encountered and conquered the challenges of even the most specialized requirements. This experience translates to efficient, economical solutions for your system's applications.



The Essential Elements