

CONNECTIONS BASED ON TRIM PRESSURE							
	15 PSI	30 PSI	50 PSI	75 PSI	100 PSI	125 PSI	150 PSI
STEAM OUTLET SIZE	6"	4"	4"	4"	4"	4"	4"
SAFETY VALVE OUTLET SIZE	(2X) 2"	2"	2"	1 1/2"	1 1/2"	1 1/4"	1 1/4"

CUSTOMER CONNECTIONS			
ITEM	DESCRIPTION	SIZE	TYPE
A	FEED WATER INLET	1"	N.P.T.
B	BLOWDOWN OUTLET	1 1/2"	N.P.T.
C	STEAM OUTLET	NOTE 11*	150#
D	SAFETY RELIEF VALVE	NOTE 11*	N.P.T.
E	WATER COLUMN DRAIN	1"	N.P.T.
F	WATER SAMPLE PORT	1/4"	N.P.T.
G	STEAM SAMPLE PORT	1/4"	N.P.T.
H	SURFACE BLOWDOWN (PLUGGED)	3/4"	N.P.T.
J	HIGH WATER PROTECTION (CAPPED)	3/4"	N.P.T.
K	POWER INLET(S)	- - -	N.P.T.
L	AUXILIARY WATER COLUMN (CAPPED)	1"	N.P.T.
M	SECONDARY SAFETY RELIEF VALVE (CAPPED)	2"	N.P.T.

EQUIPMENT SPECIFICATION CHART	
ENERGY SOURCE:	ELECTRIC
MAX. ALLOWABLE WORKING PRESSURE:	150 PSI**
BOILER INPUT:	400 KW
BOILER OUTPUT:	1,364,800 BTU/HR
STEAM OUTPUT:	1,400 LBS/HR
MIN. SAFETY RELIEF VALVE CAPACITY:	1,750 LBS/HR
WATER CAPACITY (OPERATING):	335 GAL.
APPX. DRY WEIGHT:	4,000 LBS.
APPX. OPERATING WEIGHT:	6,800 LBS.
APPX. SHIPPING WEIGHT:	4,300 LBS.
APPX. FLOODED WEIGHT:	7,500 LBS.
NUMBER OF HEATERS:	(4) - 100KW
TURNDOWN:	100:1 WITH FULL MODULATION

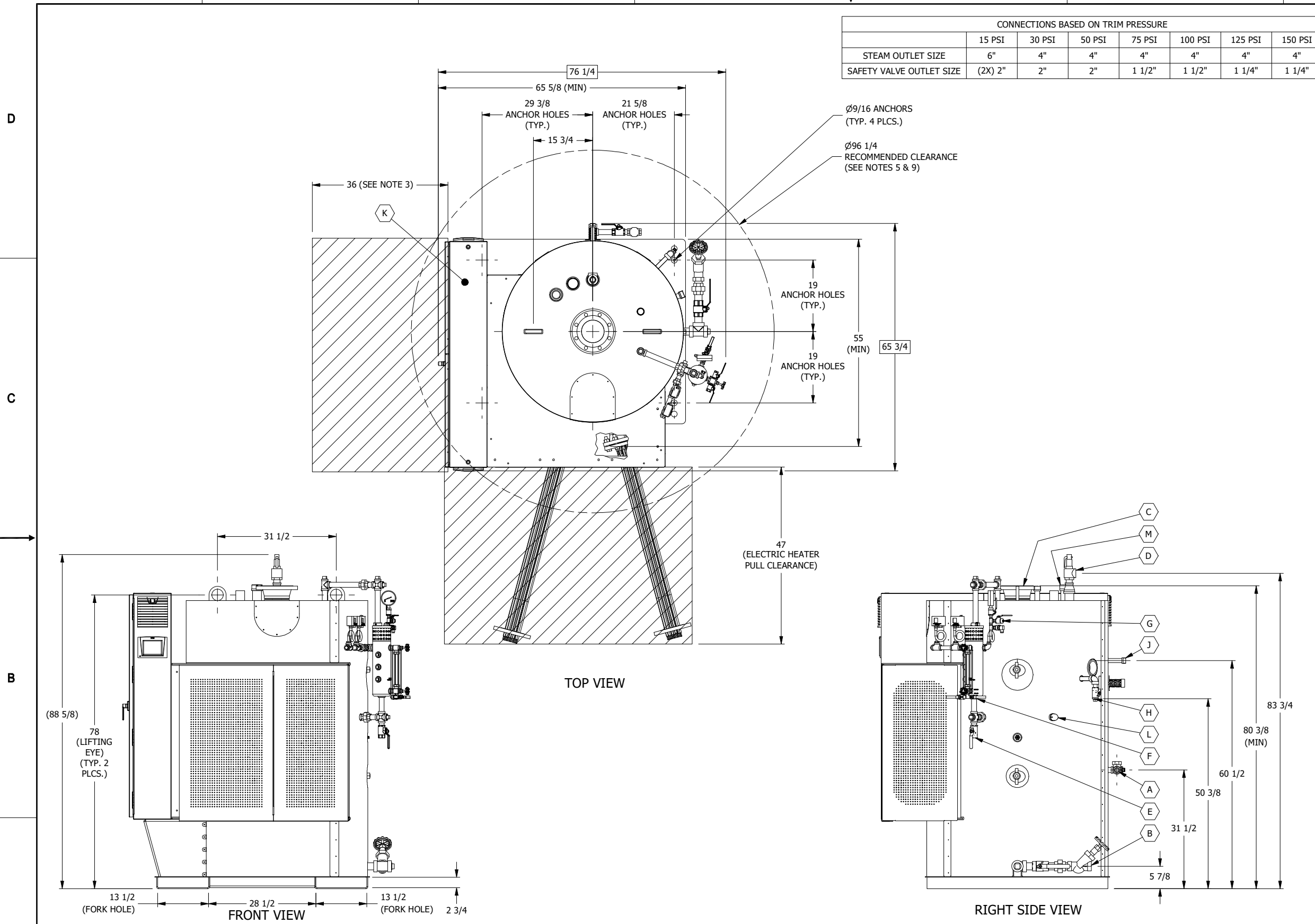

- NOTES:
- STEAM OUTPUT LB/HR: FROM 0 PSIG AT 212°F (0 KG/CM² AT 100°C)
 - ALL CLEARANCES ARE FACTORY RECOMMENDATIONS. CONSULT LOCAL JURISDICTION FOR EXACT CODE COMPLIANCE.
 - RECOMMENDED MINIMUM CLEARANCE OF 36" IN FRONT OF ELECTRICAL PANELS.
 - RECOMMENDED 36" CLEARANCE BETWEEN INSPECTION OPENINGS OF ALL BOILERS AND 18" CLEARANCE OF HANDHOLES.
 - PLEASE REFER TO THE O&M MANUAL FOR ADDITIONAL INFORMATION REGARDING CLEARANCES AND INSTALLATION INSTRUCTIONS.
 - ALL DIMENSIONS INSIDE () DENOTE REFERENCE DIMENSIONS.
 - ALL DIMENSIONS INSIDE □ DENOTE OVERALL DIMENSIONS.
 - WE RESERVE THE RIGHT TO CHANGE SPECIFICATIONS AND/OR DIMENSIONS. ALL INFORMATION IS SUBJECT TO CHANGE BASED ON ADDITION OF ANY OPTIONAL EQUIPMENT AND/OR ACCESSORIES. PLEASE CONSULT THE FACTORY FOR PROJECT SPECIFIC ESTIMATES IF ADDITIONAL OPTIONS OR ACCESSORIES ARE REQUIRED.
 - LOCAL CODES CAN SUPERCEDE RECOMMENDED CLEARANCE.
 - CONSULT MODEL TECHNICAL DATA SHEET FOR HOW TO MAINTAIN 100KA SCCR RATING.
 - *SIZES BASED ON TRIM PRESSURE AND OPTIONS.
 - **BOILER CAN BE BUILT IN COMPLIANCE WITH ASME SECTION IV CODE WITH MAWP 15 PSI.

Chromalox® www.chromalox.com
 DESCRIPTION:
 CHSI-0400 (400KW) ELECTRIC STEAM BOILER

8

7

6

5

4

3

1

D

C

B

A

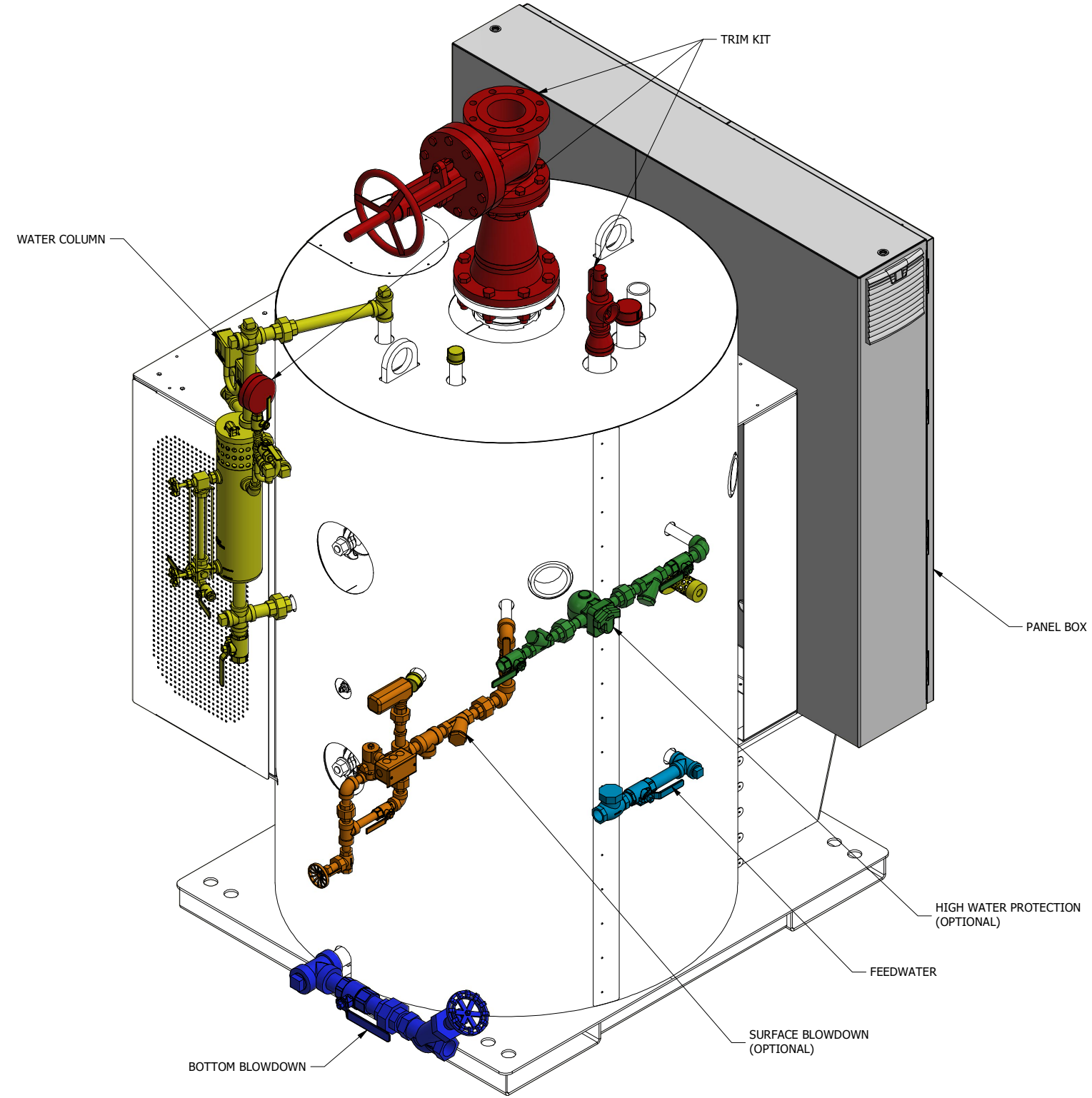

BACK RIGHT VIEW

Chromalox[®] www.chromalox.com

DESCRIPTION:
CHSI-0400 (400KW) ELECTRIC STEAM BOILER

8

7

6

5

4

3

2

1