

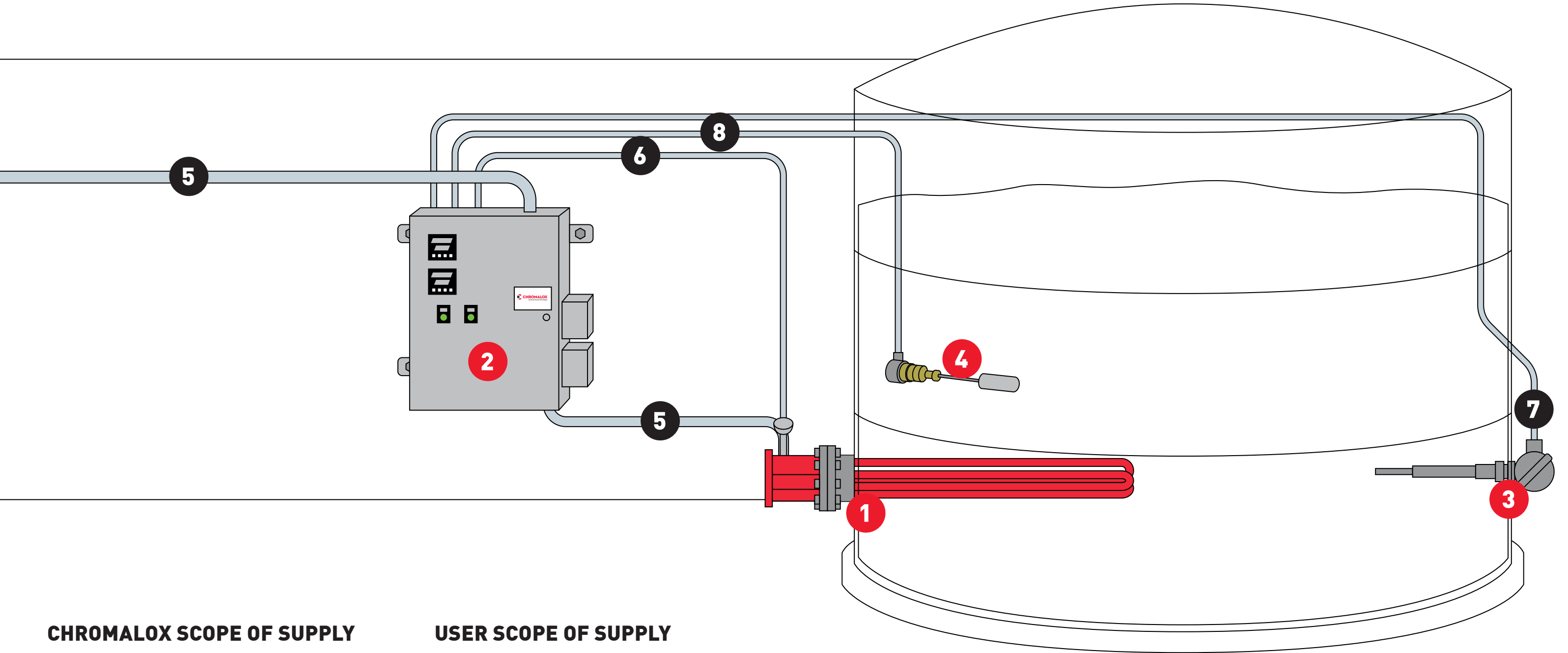

# PICK AND SHIP PROGRAM PRODUCT SELECTION GUIDE

# SCOPE OF SUPPLY



## CHROMALOX SCOPE OF SUPPLY

- 1** Electric Immersion Heater
- 2** Power Control Assembly
- 3** Temperature Sensor & Thermowell
- 4** Liquid Level Sensor

## USER SCOPE OF SUPPLY

- 5** Power Wire & Conduit
- 6** Overtemperature Sensor Wire & Conduit
- 7** Process Sensor Conduit
- 8** Liquid Level Sensor Wire & Conduit

FOR FURTHER PRODUCT DETAILS, PLEASE REFER TO THE FOLLOWING CHROMALOX DOCUMENTS:

ANSI Flange – PNS-SG-001, PNS-DS-001

Screw Plug Heaters – PNS-SG-003, PNS-DS-003

Power Control Assembly – PNS-SG-002, PNS-DS-002

Temperature Sensor, Liquid Level Sensor, Wiring & Accessories – PNS-DS-004

# ANSI Flange Pick and Ship Selection Guide

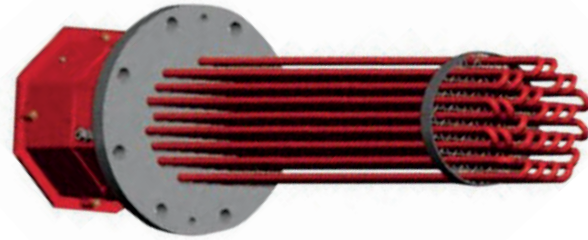

## Steps for Picking Flanged Immersion Heater

1. Calculate the kilowatt requirement and round up to the closest heater kW rating.
2. Choose the column with the appropriate application watt density.
3. Find the corresponding heater part number at the intersection of the selected heater kW rating and application watt density.
  - Confirm the selected heater part number with the data sheet PNS-DS-001 for application and installation suitability.
4. Select related Power Control Assembly and Sensor Equipment Packages by referring to documents PNS-SG-002, PNS-SG-002 & PNS-DS-004.

## Heater Selection Table – Refer to ANSI Flange Data Sheet for further technical details

kW Rating Load @ 480 V 3pH	45 WPSI Water Water/Glycol	25 WPSI Process Water Light Weight Oil <600°F Air <sup>1</sup>	15 WPSI Medium Weight Oil <1,000°F Air <sup>1</sup>	7.5 WPSI Heavy Weight Oil <1,200°F Air <sup>1</sup>
58 kW / 70 amps	155-307496-050	155-307496-046		
37 kW / 45 amps	155-307496-051	155-307496-047	155-307496-043	
24.9 kW / 30 amps	155-307496-052	155-307496-048	155-307496-044	155-307496-040
16.5 kW / 20 amps	155-307496-053	155-307496-049	155-307496-045	155-307496-041
12 kW / 14.5 amps	155-307498-798	155-307498-799	155-307498-800	
8 kW / 10 amps	155-307496-056	155-307496-055	155-307496-054	155-307496-042
5.5 kW / 6.6 amps				155-307498-805

<sup>1</sup>Air temperature ratings are for general guidelines only. Every gas application must be thoroughly reviewed for product suitability or heater damage can occur. Please refer to the Chromalox technical literature or local sales office for proper guidance.

## Choose Integral Equipment

As indicated on the Scope of Supply a proper heater installation requires the heater, power control system, and the sensors accessories to all work together for complete Thermal Loop Management. For Power Control Assemblies, please refer to documents PNS-SG-002. For Temperature and Liquid Level sensor packages, please refer to document PNS-DS-004.

# ANSI Flange Pick and Ship Data Sheet

## Heater Specifications (Common to all units)

**Electrical Rating**– 480 volts, 1 circuit, 3 phase.

**Power Terminal Enclosure**– Powder coated, color red, rated NEMA 4 / IP66, UL / cCSAus Certification.

**Power Wiring Conduit Location**– Chromalox 'Octobox' enclosure allows for user selection of conduit punch size, entry location, and entry angle to suit installation needs.

**Mechanical Installation Connection**– ANSI rated 150# flange, carbon steel material, raise face surface.

**Mechanical Installation Gasket**– Composition grade gasket is provided.

**Element Sheath**– Heater elements are sheathed with INCOLOY® 800 for superior corrosion resistance and longevity.

**Element Seals**– Conformal terminal coating over mica is provided for all heater elements.

**Element Protection**– One type K thermocouple attached to element sheath for overtemperature protection. The mechanical compression fitting boundary connection allows for thermocouple replacement, if needed.

**Element Overtemperature Electrical Enclosure**– A separate thermocouple, aluminum junction box, rated NEMA 4 / IP66 is included with a 3/4" NPT wiring connection provided.

**Thermowell**– An INCOLOY® 800 bundle thermowell is provided for customers requiring additional process temperature input locations.

**Heater Removal**– Two threaded back out holes are provided for removal of heater bundle, if needed.

Part Number	Electrical Data			Mechanical Parameters					
	WPSI Category	kW	Amp. Load	ANSI Conn. <sup>1</sup>	Immersion Length (In/mm)	Unheated Length (In/mm)	Terminal Box Height (In/mm)	Bundle Diameter <sup>2</sup> (In/mm)	Weight (lbs/kg.)
155-307496-056	45	8	10	3", 150#	18 / 457	4 / 102	8 / 205	2.88 / 73	20 / 9
155-307498-798	45	12	15	4", 150#	24 / 610	6 / 152	10 / 254	3.81 / 97	36 / 17
155-307496-053	45	16.5	20	5", 150#	24 / 610	6 / 152	10 / 254	4.62 / 117	42 / 19
155-307496-052	45	24.9	30	6", 150#	24 / 610	6 / 152	10 / 254	5.81 / 148	60 / 27
155-307496-051	45	37	45	6", 150#	24 / 610	6 / 152	10 / 254	5.81 / 148	60 / 27
155-307496-050	45	58	70	6", 150#	36 / 914	6 / 152	10 / 254	5.81 / 148	71 / 32
155-307496-055	25	8	10	3", 150#	24 / 610	4 / 102	8 / 205	2.88 / 73	21 / 10
155-307498-799	25	12	15	4", 150#	36 / 914	6 / 152	10 / 254	3.81 / 97	43 / 20
155-307496-049	25	16.5	20	5", 150#	36 / 914	6 / 152	10 / 254	4.62 / 125	49 / 22
155-307496-048	25	24.9	30	5", 150#	48 / 1219	6 / 152	10 / 254	4.62 / 117	56 / 25
155-307496-047	25	37	45	6", 150#	48 / 1219	6 / 152	10 / 254	5.81 / 148	83 / 38
155-307496-046	25	58	70	8", 150#	36 / 914	6 / 152	10 / 254	7.75 / 197	124 / 56
155-307496-054	15	8	10	3", 150#	36 / 914	4 / 102	8 / 205	2.88 / 73	22 / 10
155-307498-800	15	12	15	4", 150#	48 / 1218	6 / 152	10 / 254	3.81 / 97	50 / 23
155-307496-045	15	16.5	20	5", 150#	48 / 1219	6 / 152	10 / 254	4.62 / 119	56 / 25
155-307496-044	15	24.9	30	6", 150#	48 / 1219	6 / 152	10 / 254	5.81 / 148	83 / 38
155-307496-043	15	37	45	8", 150#	36 / 914	6 / 152	10 / 254	7.75 / 197	124 / 56
155-307498-805	7.5	5.5	7	4", 150#	48 / 1219	6 / 152	10 / 254	3.81 / 97	50 / 23
155-307496-042	7.5	8	10	5", 150#	48 / 1219	6 / 152	10 / 254	4.62 / 117	56 / 25
155-307496-041	7.5	16.5	20	8", 150#	36 / 914	6 / 152	10 / 254	7.75 / 197	124 / 56
155-307496-040	7.5	24.9	30	8", 150#	48 / 1219	6 / 152	10 / 254	7.75 / 197	144 / 65

<sup>1</sup>Application pressure and temperature ratings must conform with ANSI guidelines to ensure safe operation of the unit. Every gas application must be thoroughly reviewed for product suitability or heater damage can occur. Please refer to the Chromalox technical literature or local sales office for proper guidance.

<sup>2</sup>The bundle diameter is designed to fit through a standard Schedule 40 pipe connection. Chromalox recommends a minimum of 3mm diameter clearance on all sides for any other installation to avoid damage to the heater elements.

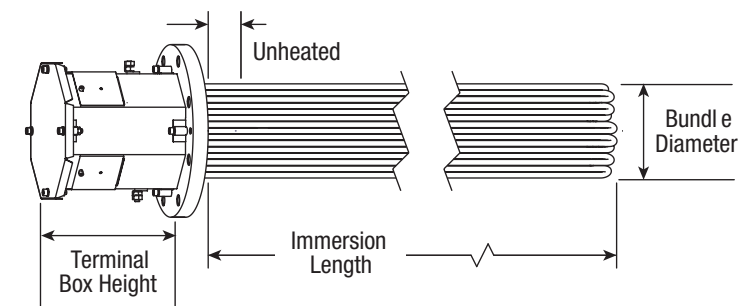

# Circulation Pick and Ship Selection Guide

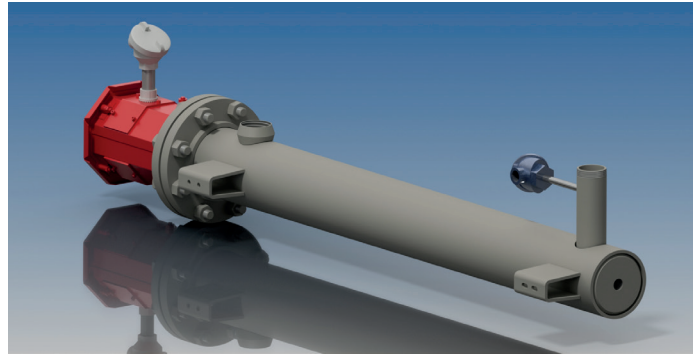

## Steps for Picking Circulation Heater

1. Calculate the kilowatt requirement and round up to to the closest heater kW rating.
2. Find the corresponding heater part number at the intersection of the selected heater kW rating and application watt density.
3. Confirm the selected heater part number with the Circulation product data sheet for application and installation suitability.
4. Select related Power Control Assembly and Sensor Equipment Packages by referring to documents PNS-SG-002 & PNS-DS-004.

## Heater Selection Table – Refer to ANSI Flange Data Sheet for further technical details

kW Rating Load @ 480 V 3pH	45 WPSI Water Water/Glycol	25 WPSI Process Water Light Weight Oil <600°F Air <sup>1</sup>	15 WPSI Medium Weight Oil <1,000°F Air <sup>1</sup>	7.5 WPSI Heavy Weight Oil <1,200°F Air <sup>1</sup>
<b>58 kW / 70 Amps</b>	054-307616-006	054-307616-012		
<b>37 kW / 45 Amps</b>	054-307616-005	054-307616-011	054-307616-017	
<b>24.9 kW / 30 Amps</b>	054-307616-004	054-307616-010	054-307616-016	054-307616-021
<b>16.5 kW / 20 Amps</b>	054-307616-003	054-307616-009	054-307616-015	054-307616-020
<b>12 kW / 15 Amps</b>	054-307616-002	054-307616-008	054-307616-014	
<b>8 kW / 10 Amps</b>	054-307616-001	054-307616-007	054-307616-013	054-307616-019
<b>5.5 kW / 6.6 Amps</b>				054-307616-018

<sup>1</sup>Air temperature ratings are for general guidelines only. Every gas application must be thoroughly reviewed for application suitability or heater damage can occur. Please refer to the Chromalox technical literature or local sales office for proper guidance.

<sup>2</sup>Application pressure and temperature ratings must conform with ANSI guidelines to ensure safe operation of the unit. Proper temperature and pressure ratings must be observed for safe operation. Refer to Chromalox Technical section for further details.

## Choose Integral Equipment

As indicated on the Scope of Supply a proper heater installation requires the heater, power control system, and the sensors accessories to all work together for complete Thermal Loop Management. For Power Control Assemblies, please refer to documents PNS-SG-002. For Temperature and Liquid Level sensor packages, please refer to document PNS-DS-004.

# Circulation Product Data Sheet

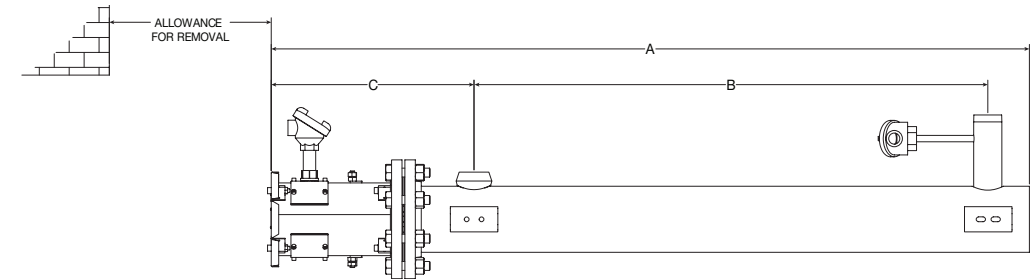

## Heater Specifications (by part number)

Part Number	Electrical Data			Mechanical Parameters							
	WPSI Category	kW	Amp. Load	Vessel Const. <sup>1</sup>	Inlet Conn. (FNPT)	Outlet Conn. (MNPT)	Overall Length 'A' Dim (in/mm)	Center to Center 'B' Dim (in/mm)	Housing to Inlet 'C' Dim (in/mm)	Min. Allowance for Removal (in/mm)	Weight (lbs/kg.)
054-307616-001	45	8	10	3", 150#	1-1/2"	1-1/2"	49.22 / 1251	33 / 839	12.97 / 330	24 / 610	65 / 30
054-307616-002	45	12	15	4", 150#	2"	2"	61.66 / 1567	43.25 / 1099	14.91 / 379	30 / 762	109 / 50
054-307616-003	45	16.5	20	5", 150#	2"	2"	63.81 / 1621	43.25 / 1099	17.06 / 434	30 / 762	139 / 64
054-307616-004	45	24.9	30	6", 150#	2"	2"	63.87 / 1623	43.25 / 1099	17.12 / 435	30 / 762	182 / 83
054-307616-005	45	37	45	6", 150#	2"	2"	63.87 / 1623	43.25 / 1099	17.12 / 435	30 / 762	182 / 83
054-307616-006	45	58	70	6", 150#	2"	2"	63.87 / 1623	43.25 / 1099	17.12 / 435	42 / 1067	193 / 88
054-307616-007	25	8	10	3", 150#	1-1/2"	1-1/2"	49.22 / 1251	33 / 839	12.97 / 330	30 / 762	66 / 30
054-307616-008	25	12	15	4", 150#	2"	2"	61.66 / 1567	43.25 / 1099	14.91 / 379	42 / 1067	116 / 53
054-307616-009	25	16.5	20	5", 150#	2"	2"	63.84 / 1622	43.25 / 1099	17.06 / 434	42 / 1067	146 / 67
054-307616-010	25	24.9	30	5", 150#	2"	2"	63.81 / 1621	43.25 / 1099	17.06 / 434	54 / 1372	153 / 70
054-307616-011	25	37	45	6", 150#	2"	2"	63.87 / 1623	43.25 / 1099	17.12 / 435	54 / 1372	105 / 48
054-307616-012	25	58	70	8", 150#	2"	2"	63.96 / 1625	43.25 / 1099	14.15 / 360	42 / 1067	305 / 139
054-307616-013	15	8	10	3", 150#	1-1/2"	1-1/2"	49.22 / 1251	33 / 839	12.97 / 330	42 / 1067	67 / 31
054-307616-014	15	12	15	4", 150#	2"	2"	61.66 / 1567	43.25 / 1099	14.91 / 379	54 / 1372	123 / 56
054-307616-015	15	16.5	20	5", 150#	2"	2"	63.81 / 1621	43.25 / 1099	17.06 / 434	54 / 1372	153 / 70
054-307616-016	15	24.9	30	6", 150#	2"	2"	63.87 / 1623	43.25 / 1099	17.12 / 435	54 / 1372	205 / 93
054-307616-017	15	37	45	8", 150#	2"	2"	63.96 / 1625	43.25 / 1099	14.15 / 360	42 / 1067	305 / 139
054-307616-018	7.5	5.5	7	4", 150#	2"	2"	61.66 / 1567	33 / 839	14.91 / 379	54 / 1372	123 / 56
054-307616-019	7.5	8	10	5", 150#	2"	2"	63.81 / 1621	43.25 / 1099	17.06 / 434	54 / 1372	153 / 70
054-307616-020	7.5	16.5	20	8", 150#	2"	2"	63.96 / 1625	43.25 / 1099	14.15 / 360	42 / 1067	305 / 139
054-307616-021	7.5	24.9	30	8", 150#	2"	2"	63.96 / 1625	43.25 / 1099	14.15 / 360	54 / 1372	325 / 148

<sup>1</sup>Air temperature ratings are for general guidelines only. Every gas application must be thoroughly reviewed for application suitability or heater damage can occur. Please refer to the Chromalox technical literature or local sales office for proper guidance.

<sup>2</sup>Application pressure and temperature ratings must conform with ANSI guidelines to ensure safe operation of the unit. Proper temperature and pressure ratings must be observed for safe operation. Refer to Chromalox Technical section for further details.

## Heater Specifications (Common to all units)

**Electrical Rating** – 480 volts, 1 circuit, 3 phase

**Power Terminal Enclosure** – Powder coated, color red, Rated NEMA 4 / IP66, UL / cCSAus Certification

**Power Wiring Conduit Location** – Chromalox 'Octobox' enclosure allows for user selection of conduit punch size, entry location, and entry angle to suit installation needs.

**Pressure Vessel** – Painted exterior, Carbon Steel construction, ANSI rated 150# flange heater with NPT process connections

**Installation Gasket** – Composition grade gasket is provided.

**Element Sheath** – Heater elements are sheathed with INCOLOY 800 for superior corrosion resistance and longevity.

**Element Seals** – Conformal terminal coating over mica is provided for all heater elements.

**Element Protection** – One type K thermocouple attached to element sheath for overtemperature protection. The mechanical compression fitting boundary connection allows for thermocouple replacement, if needed.

**Element Overtemperature Sensor Electrical Enclosure** – A separate aluminum junction box, rated NEMA 4 / IP66 is included with a 3/4" NPT wiring connection provided.

**Process Temperature Sensor** – One type J thermocouple in a thermowell is provided in the outlet piping.

**Process Sensor Electrical Enclosure** – A separate aluminum junction box, rated NEMA 4 / IP66 is included with a 3/4" NPT wiring connection

**Thermowell** – An INCOLOY 800 bundle thermowell is provided for customers requiring an additional process temperature input location.

**Inlet / Outlet Connection** – Threaded NPT connection, sized per specification.

**Mounting Lugs** – One fixed mounting lugs and one slotted lug (to allow for thermal expansion) is provided.

**Heater Removal** – Two threaded back out holes are provided for removal of heater bundle, if needed. Be sure to allow room for removal, during installation.

# Screw Plug Pick and Ship Selection Guide

## Steps for Picking Screw Plug Immersion Heater

1. Calculate the kilowatt requirement and round up to the closest heater kW rating.
2. Choose the column with the appropriate application watt density.
3. Find the corresponding heater part number at the intersection of the selected heater kW rating and application watt density.
  - Confirm the selected heater part number with the data sheet PNS-DS-003 for application and installation suitability.
4. Select related Power Control Assembly and Sensor Equipment Packages by referring to documents PNS-SG-002, PNS-SG-002 & PNS-DS-004.

## Heater Selection Table – Refer to Screw Plug Data Sheet for further technical details

kW Rating Load @ 480 V 3pH	45 WPSI Water <sup>1</sup> Water/Glycol	25 WPSI Process Water Light Weight Oil <600°F Air <sup>2</sup>	15 WPSI Medium Weight Oil <1,000°F Air <sup>2</sup>	7.5 WPSI Heavy Weight Oil <1,200°F Air <sup>2</sup>
1 kW / 1.2 Amps				156-306351-836
1.5 kW / 1.8 Amps				156-306351-839
2 kW / 2.4 Amps			156-306351-842	156-306351-840
3 kW / 3.6 Amps			156-306351-843	156-306351-841
4 kW / 4.8 Amps	156-306351-854	156-306351-846	156-306351-844	
6 kW / 7.2 Amps		156-306351-847	156-306351-845	
8 kW / 9.6 Amps	156-306351-850			
10 kW / 12 Amps	156-306351-851	156-306351-848		

<sup>1</sup>Under the U.S. Federal Safe Drinking Water Act, it is unlawful to install or use this product in any service that comes into contact with water for human consumption (including drinking, food or beverage preparation, hand washing, or teeth brushing). This product is intended exclusively for use in non-potable service.

<sup>2</sup>Air temperature ratings are for general guidelines only. Every gas application must be thoroughly reviewed for product suitability or heater damage can occur. Please refer to the Chromalox technical literature or local sales office for proper guidance.

## Choose Integral Equipment

As indicated on the Scope of Supply a proper heater installation requires the heater, power control system, and the sensors accessories to all work together for complete Thermal Loop Management. For Power Control Assemblies, please refer to documents PNS-SG-002 and PNS-SG-002. For Temperature and Liquid Level sensor packages, please refer to document PNS-DS-004.

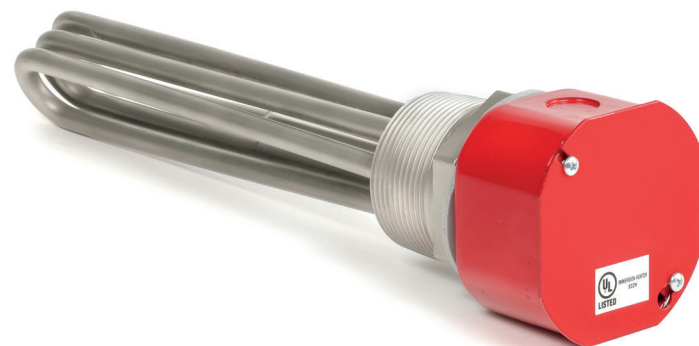

# Screw Plug Pick and Ship Data Sheet for Corrosive Solution, Non-Potable Water and Gas Applications

## Heater Specifications (Common to all units)

**Electrical Rating**– 480 volts, 1 circuit, 1 or 3 phase

**Power Terminal Enclosure**– Powder coated, color red, rated NEMA 1 / IP10, UL / cCSAus Certification

**Power Wiring Conduit Location**– Four 3/4" Knock outs are located on the sides of the terminal housing to suit installation needs.

**Mechanical Installation Connection**– Heaters are provided with a 304SST, 2" NPT screw plug for easy installation.

**Element Sheath**– Heater elements are sheathed with INCOLOY® 800 for superior corrosion resistance and longevity.

**Element Seals**– Conformal terminal coating over mica is provided for all heater elements.

**Thermowell**– An INCOLOY® 800 bundle thermowell is provided for customers requiring additional process temperature input locations.

**Wiring** – Heaters are field convertible from three phase to single phase, allowing for versatile installation.

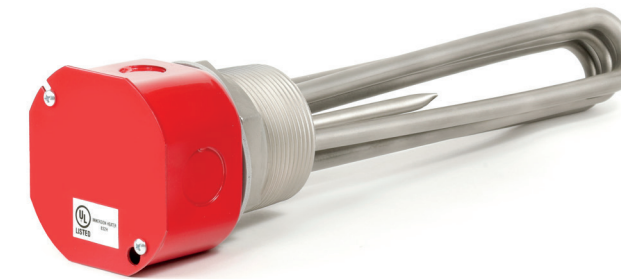

Part Number	Electrical Data				Mechanical Parameters			
	WPSI Category	kW	3 Ph Amp. Load	1 Ph Amp. Load	Immersion Length (In/mm)	Unheated Length (In/mm)	Bundle Diameter <sup>2</sup> (In/mm)	Weight (lbs/kg.)
156-306351-836	7.5	1.0	1.2	2.1	18 / 457	2 / 51	1.9 / 48.4	5 / 2.3
156-306351-839	7.5	1.5	1.8	3.1	24 / 610	2 / 51	1.9 / 48.4	6 / 2.7
156-306351-840	7.5	2.0	2.4	4.2	36 / 914	2 / 51	1.9 / 48.4	8 / 3.6
156-306351-841	7.5	3.0	3.6	6.3	48 / 1219	2 / 51	1.9 / 48.4	10 / 4.5
156-306351-842	15	2.0	2.4	4.2	18 / 457	2 / 51	1.9 / 48.4	5 / 2.3
156-306351-843	15	3.0	3.6	6.3	24 / 610	2 / 51	1.9 / 48.4	6 / 2.7
156-306351-844	15	4.0	4.8	8.3	36 / 914	2 / 51	1.9 / 48.4	8 / 3.6
156-306351-845	15	6.0	7.2	12.5	48 / 1219	2 / 51	1.9 / 48.4	10 / 4.5
156-306351-846	25	4.0	4.8	8.3	24 / 610	2 / 51	1.9 / 48.4	6 / 2.7
156-306351-847	25	6.0	7.2	12.5	36 / 914	2 / 51	1.9 / 48.4	8 / 3.6
156-306351-848	25	10.0	12.0	20.8	48 / 1219	2 / 51	1.9 / 48.4	10 / 4.5
156-306351-854	45	4.0	4.8	8.3	12 / 305	2 / 51	1.9 / 48.4	4 / 1.8
156-306351-850	45	8.0	9.6	16.7	24 / 610	2 / 51	1.9 / 48.4	6 / 2.7
156-306351-851	45	10.0	12.0	20.8	36 / 914	2 / 51	1.9 / 48.4	8 / 3.6

<sup>1</sup>Application pressure and temperature ratings must conform with ANSI guidelines to ensure safe operation of the unit. Every gas application must be thoroughly reviewed for product suitability or heater damage can occur. Please refer to the Chromalox technical literature or local sales office for proper guidance.

<sup>2</sup>The bundle diameter is designed to fit through a standard Schedule 40 pipe connection. Chromalox recommends a minimum of 3mm diameter clearance on all sides for any other installation to avoid damage to the heater elements.

# Duct Heater Pick & Ship Selection Guide

## Steps for Picking Duct Heaters

1. Calculate the kilowatt requirement and round up to the closest heater kW rating.
2. Choose the column with the insertion length (duct width).
3. Find the corresponding heater part number at the intersection of the selected heater kW rating and application watt density.
  - Confirm the selected heater part number with the data sheet PNS-DS-005 for application and installation suitability.
4. Select any accessories based on the installation needs.
  - Refer to product data sheet PNS-DS-005 for details.

## Heater Selection Table – Refer to Duct Heater Data Sheet for further technical details

kW Rating Load @ 480 V 3pH	B = 20-1/4" (514mm)	B = 25" (635mm)	B = 32-1/4" (826mm)
9 kW / 10.8 Amps	106-553126-198		
18 kW / 21.7 Amps	106-553126-199		
27 kW / 32.5 Amps	106-553126-189		
36 kW / 43.4 Amps	106-553126-200		
45 kW / 54.2 Amps	106-553126-201		
54 kW / 65 Amps	106-553126-195		
63 kW / 75.9 Amps	106-553126-202		
79 kW / 95.1 Amps		106-553126-203	
105 kW / 126.4 Amps			106-553126-204

## Choose Accessories

As indicated on the Scope of Supply a proper heater installation requires the heater, power control system, and the sensors accessories to all work together for complete Thermal Loop Management. For Power Control Assemblies, please refer to documents PNS-SG-002 and PNS-SG-002. For Temperature and Liquid Level sensor packages, please refer to document PNS-DS-004.



# Duct Heater Pick & Ship Data Sheet for Air Applications up to 800°F (427°C)

## Heater Specifications (Common to all units)

**Electrical Rating**– 480 volts, 3 phase

**Power Terminal Enclosure**– Epoxy coated, color gray, rated NEMA 1 / IP10, UL and CSA component recognized.

**Power Wiring Conduit Location**– 3/4" Knock outs are located on the sides of the terminal housing to suit installation needs.

**Mechanical Installation Connection**– Heaters are provided with a 1/4" thick epoxy painted steel flange and 3/8" bolt holes for easy installation.

**Element Sheath** – Heater elements are sheathed with INCOLOY® 840 for superior corrosion resistance and longevity.

**Element Seals**– Silicon Resin coating over mica is provided for all heater elements.

**Thermocouple**– All Heaters are provided with a type "K" over-temperature thermocouple.

A separate, remote thermowell and process sensor is always recommended for the best heating results – refer to Accessories Data Sheet section for Chromalox provided kits.

**Wiring** – Heaters are factory bussed for easy wiring.

Part Number	Model	Electrical Data					Mechanical Parameters							
		kW	Volts	3 Ph Amp. Load	Elem	Circ	A Dim. (In/mm)	B Dim. (In/mm)	C Dim. (In/mm)	D Dim. (In/mm)	E Dim. (In/mm)	F Dim. (In/mm)	G Dim. (In/mm)	Weight (lbs/kg.)
106-553126-198	ADH-B-009T	9	480	10.8	3	1	28-1/4 (718)	20-1/4 (514)	3-3/4 (95)	7-1/2 (191)	4 (102)	4 (102)	3 (76)	35 (15.9)
106-553126-199	ADH-B-018T	18	480	21.7	6	1	28-1/4 (718)	20-1/4 (514)	6-3/4 (171)	10-1/2 (267)	7 (178)	7 (178)	3 (76)	55 (25)
106-553126-189	ADH-B-027T	27	480	32.5	9	1	28-1/4 (718)	20-1/4 (514)	9-3/4 (248)	13-1/2 (343)	10 (254)	10 (254)	3 (76)	75 (34.1)
106-553126-200	ADH-B-036T	36	480	43.4	12	1	28-1/4 (718)	20-1/4 (514)	12-3/4 (324)	16-1/2 (419)	13 (330)	13 (330)	3 (76)	95 (43.2)
106-553126-201	ADH-B-045T	45	480	54.2	15	5	28-1/4 (718)	20-1/4 (514)	15-3/4 (400)	19-1/2 (495)	16 (406)	17 (432)	3 (76)	115 (52.3)
106-553126-195	ADH-B-054T	54	480	65	18	2	28-1/4 (718)	20-1/4 (514)	18-3/4 (476)	22-1/2 (572)	19 (483)	20 (508)	3 (76)	135 (61.4)
106-553126-202	ADH-B-063T	63	480	75.9	21	7	28-1/4 (718)	20-1/4 (514)	21-3/4 (552)	25-1/2 (648)	22 (559)	23 (584)	3 (76)	155 (70.5)
106-553126-203	ADH-B-079T	79	480	95.1	21	7	33 (838)	25 (635)	21-3/4 (552)	25-1/2 (648)	22 (559)	23 (584)	3 (76)	180 (81.8)
106-553126-204	ADH-B-105T	105	480	126.4	21	7	40-1/2 (1029)	32-1/2 (826)	21-3/4 (552)	25-1/2 (648)	22 (559)	23 (584)	3 (76)	215 (97.7)

<sup>1</sup>To ensure a long life, terminal enclosure temperatures should be kept below 400°F (205°C). See figure 2. An estimated pressure drop can be calculated using figure 1. Sheath temperature should not exceed 1000°F (538°C), see figure 3.

# Power Control Assembly Selection Guide

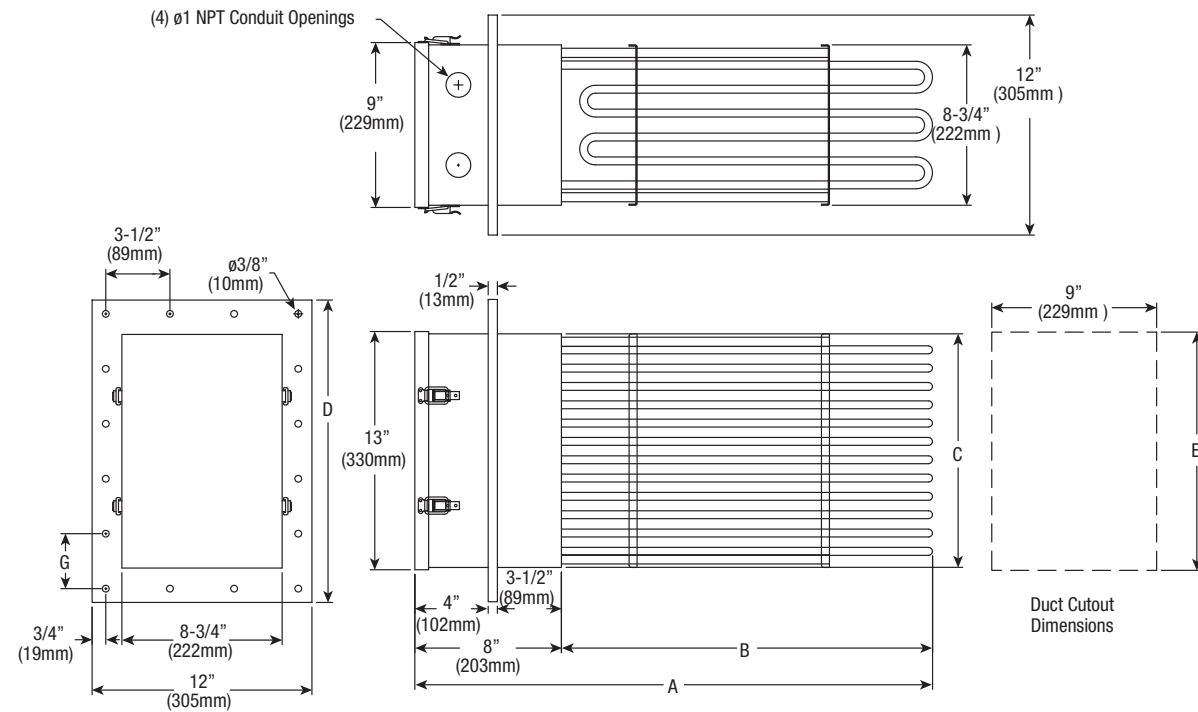

FIGURE 1: ADH-B TUBULAR DUCT HEATER  
PRESSURE DROP VS. VELOCITY

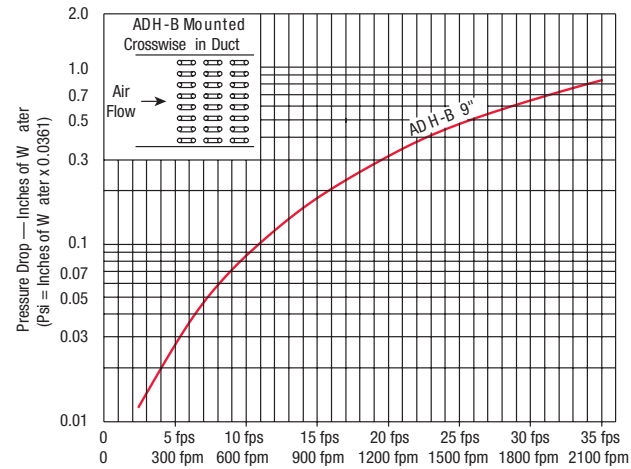

FIGURE 2: ADH-B Terminal Box  
Temperatures Field Wiring Selection Guide

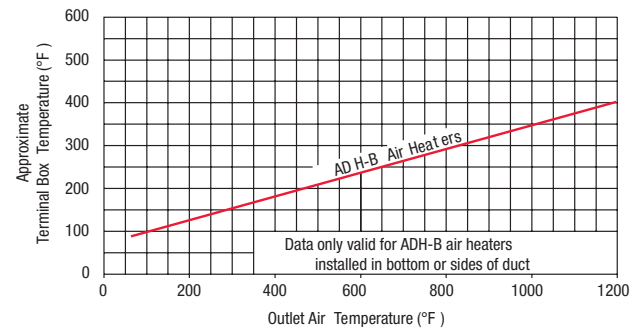
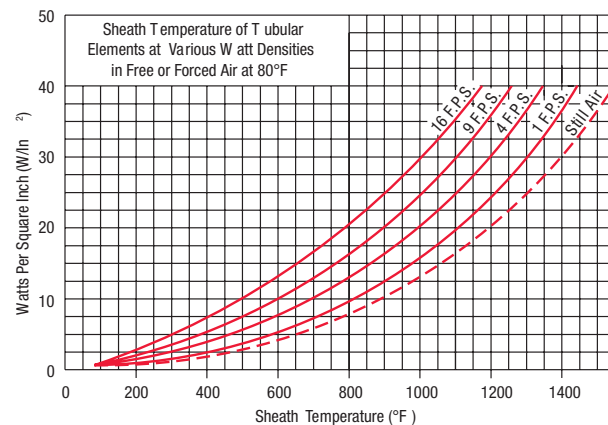

FIGURE 3: TUBULAR AIR HEATING SHEATH  
TEMPERATURE VS. WATT DENSITY



MODEL: CPCA-S1-75E4C  
PART NO: 484211-001



MODEL: CPCA-S1-75E4H  
PART NO: 484211-002



MODEL: CPCA-S1-75E4V  
PART NO: 484211-003

## Steps for Picking Power Control Assembly

1. Ensure matching heater is rated for 480 volts, 3 phase, 1 circuit, and up to 75 amps.
2. If an installer is providing their own process and overtemperature control and overtemperature signals, choose model CPCA-S1-75E4C.
3. If process and overtemperature control is to be provided by Chromalox, choose the controller location option of either:
  - Model CPCA-S1-75E4H features DIN rail mount (internal) controllers that will be secured inside the enclosure during heater operation.
  - Model CPCA-S1-75E4V features DOOR mounted (external) controllers that will be accessible during operation.
4. Confirm the selected power control assembly with the product data sheet (PNS-DS-003) for application and installation suitability.
5. Select related Sensor Equipment Packages by referring to document PNS-DS-004.

## Power Control Assembly Selection Table - Refer to Data Sheet for further technical details

Model Description	Part Number	Power Control Type	Process Controller or Input Signal	Overtemperature Controller or Input Signal	Controller Mounting Location
CPCA-S1-75E4C 480V 3ph	484211-001	Proportional	Customer Supplied 4-32Vdc	Customer Supplied Relay	n/a
CPCA-S1-75E4H 480V 3ph	484211-002	Proportional	1020-SR000	1030-1R000	DIN Rail
CPCA-S1-75E4V 480V 3ph	484211-003	Proportional	6040-SR000	6050-1R000	Door Mount

## Choose Integral Equipment

As indicated on the Scope of Supply a proper heater installation requires the heater, power control system, and the sensors accessories to all work together for complete Thermal Loop Management. For Power Control Assemblies, please refer to documents PNS-SG-002 and PNS-SG-002. For Temperature and Liquid Level sensor packages, please refer to document PNS-DS-004.

# Power Control Assembly Pick and Ship Product Data Sheet

## Power Control Assembly Illustrations



MODEL: CPCA-S1-75E4C  
PART NO: 484211-001



MODEL: CPCA-S1-75E4H  
PART NO: 484211-002



MODEL: CPCA-S1-75E4V  
PART NO: 484211-003

## Power Control Assembly Specifications

### Common Features on all Units

**Electrical Rating** – 480 volts, 3 phase, 1 circuit, up to 75 amps

**Power Terminal Enclosure** – Powder coated, color gray, rated NEMA 4 / IP66, UL / cCSAus Certification

**Power Wiring Conduit Location** – Enclosure can be punch drilled to suit incoming power connection size and location.

**Power Control Type** – Full proportional power control utilizing a SSR assembly, rated up to 75 amps at 480V 3ph

**Shutdown Capability** – One shutdown contactor is provided for complete power off capability.

**Optional Shutdown Connection** – Connection is shipped jumpered, and can be reconfigured to accept a customer relay signal for heater operation.

**Heat Sinks** – External heat sinks are provided for temperature regulation, pre-mounted to the enclosure

**Mounting Location** – Enclosure is designed for mounting in an environment up to NEMA 4 IP66 rating with a maximum of 40°C and minimum of 0°C ambient, out of direct sunlight.

**Short Circuit Current Rating** – Assembly is rated for up to 5kA SCCR.

### Unique Features by Model Name

**Model CPCA-S1-75E4C** includes terminal blocks for customer provided control and overtemperature signal. External display includes a Power On light indicator.

**Model CPCA-S1-75E4H** includes a Chromalox 1020 process and 1030 overtemperature controller, DIN rail mounted, for process and overtemperature control. External display includes a Power On, Heater Enabled, and Overtemperature Alarm light.

**Model CPCA-S1-75E4V** includes a Chromalox 6040 process and 6050 overtemperature controller, door mounted, for process and overtemperature control. External display includes the 6040 process controller, 6050 overtemperature controller, Power On, Heater Enable, and Overtemperature Alarm light via the 6050 display.

# Pick and Ship Sensor Equipment Data Sheet

## Specifications

### Temperature Sensor Package

Each Temperature Sensor Package will include a process sensor, sensor wire, and a 304 stainless steel thermowell with a 3/4" NPT boundary connection, 7-1/2" insertion length, and lagging extension for up to 3" of insulation clearance.

- Part PSKS-J4SS50-0001 is intended for sensor locations requiring <50 feet of wiring. The kit includes a thermowell, matching type J thermocouple, and 50 ft of thermocouple wire
- Part PSKS-RTD4SS200-0002 is intended for sensor locations requiring <200 ft of wiring. The kit includes a thermowell, matching RTD, and 200 ft of RTD wire

## Temperature Sensor Package Technical Details

### Thermowell Dimensions

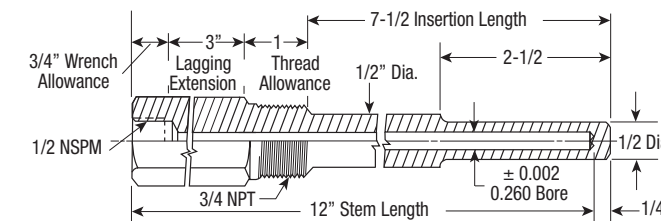

**Note:** NPSM internal pipe thread will accept both NPT and NPS male threads

### Sensor Connection Head Dimensions

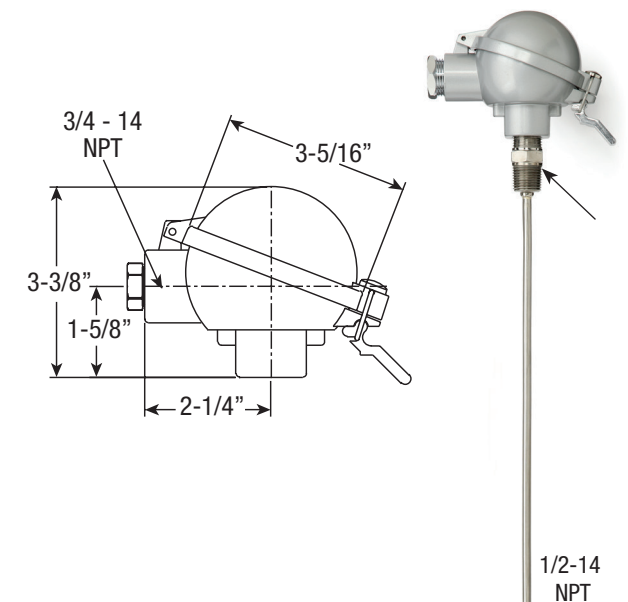

Type J thermocouple wire is 20 gauge solid Iron/Constantan wire with Teflon insulation.

RTD wire is 3 wire, 16 gauge, copper twisted-shield with polyvinyl insulation.

## Specifications

### Liquid Level Sensor Package

Having a liquid level switch in the application is vital to protecting the heating equipment by ensuring proper shutdown of the heater when the level drops below the threshold point. Select between a brass level switch with simple terminal wiring or a more robust stainless steel model with Class I Group C,D / Class II Group E,F, G explosion-proof terminal housing.

**Part PSKS-BNL-0003** is intended for side mounting in clean water applications, non-hazardous area for temperatures up to 400°F. Wiring is handled by simply connecting to the leads with a conduit or a connection head directly coupled to the brass fitting.

**Part PSKS-6SSYH-0004** is intended for side mounting in water, oil, or caustic solution applications with a minimum specific gravity of 0.7. It can be used in hazardous area installations, being rated for Class 1 Groups C, D / Class II Group E, F, G areas. Wiring is via the explosion-proof terminal enclosure.



PSKS-BNL-0003



PSKS-6SSYH-0004

### Dimensions - In (mm)

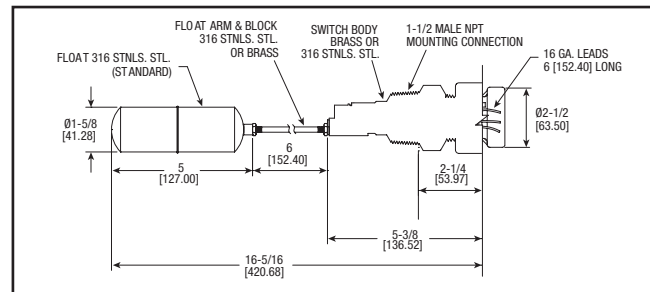

### Dimensions - In (mm)

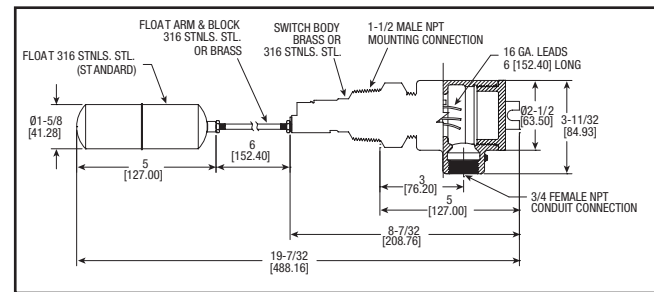

## Specifications

PSKS-BNL-0003	
Temperature Range	Min: 4°F / Max: 400°F
Pressure Limit (Body)	1000 PSIG
Pressure Limit (Float)	100 PSIG
Conduit Connection	3/4" FNPT
Process Connection	1-1/2" MNPT
Materials of Construction	Body: Brass / Float: 316 SST
Switch Type	SPDT Snap Switch
Electrical Ratings	5A @ 125/250VAC
Weight	4.56 lb

PSKS-6SSYH-004	
Temperature Range	Min: 4°F / Max: 400°F
Pressure Limit (Body)	2000 PSIG
Pressure Limit (Float)	100 PSIG
Conduit Connection	3/4" FNPT
Process Connection	1-1/2" MNPT
Materials of Construction	Body: 316 SST / Float: 316 SST
Switch Type	SPDT Snap Switch
Electrical Ratings	5A @ 125/250VAC
Weight	4.56 lb

## CHROMALOX WORLDWIDE LOCATIONS



- Sales Offices
- Manufacturing Facilities

### Chromalox Headquarters

103 Gamma Drive  
Pittsburgh, PA 15238  
USA

Phone: (412) 967-3800  
Fax: (412) 967-5148  
Toll-Free: 1-800-443-2640

email: sales@chromalox.com  
www.chromalox.com

### Brazil

Tel: ++55 11 4615-9198

email: fabio.yamasaki@chromalox.com  
www.chromalox.com

### Canada

Tel: 877-238-4754  
Fax: 888-292-9607

email: sales@chromalox.com  
www.chromalox.com

### China

Tel: +86 (0) 21-5866-8802  
Fax: +86 (0) 21-5866-8803

email: shanghai.office@chromalox.com  
www.chromalox.cn

### France

Tel: +33 (0) 3 23 74 39 39  
Fax: +33 (0) 3 23 74 39 00

email: ventes@chromalox.fr  
www.chromalox.fr

### Germany

Tel: +49 (0) 231-58 44 990-0  
Fax: +49 (0) 231-58 44 990-9

email: Kontakt@chromalox.com  
www.chromalox.de

### Middle East

Tel: +971 4 8879776  
Fax: +971 4 8879793

email: middle-eastsales@chromalox.com  
www.chromalox.com

### India

Tel: +91-11-25623134  
Fax: +91-11-25623480

email: indiasales@chromalox.com  
www.chromalox.in

### Singapore

Tel: +65 (0) 6339 1228  
Fax: +65 (0) 6339 2648

email: singapore@chromalox.com  
www.chromalox.com

### Thailand

Tel: +66 (0) 38 190916  
Fax: +66 (0) 38 190919

email: asiasales@chromalox.com  
www.chromalox.com

### United Kingdom

Tel: +44 (0) 20 8665 8900  
Fax: +44 (0) 20 8689 0571

email: uksales@chromalox.com  
www.chromalox.co.uk



PNS-DS-004