

# Rosemount™ 248 Wireless Temperature Transmitter



- Standard temperature transmitter offers a wireless solution for process monitoring
- Optimize plant efficiency and increase measurement reliability with industry-proven capabilities and specifications
- Emerson™ Smart Wireless delivers innovative wireless solutions for temperature measurement and overall transmitter performance
- Explore the benefits of Complete Point Solutions™ from Rosemount Temperature

# Rosemount 248 Wireless Temperature Transmitter

## Standard temperature transmitter offers a cost effective solution for wireless process monitoring

- Single sensor capability with universal sensor inputs (RTD, T/C, mV, ohms)
- IEC-approved *WirelessHART*® protocol
- Large LCD display (only available with enclosure option code P)

## Optimize plant efficiency and increase measurement reliability with industry-proven capabilities and specifications

- One-year stability rating reduces maintenance costs
- User-centric device dashboards communicate important diagnostics and ensure process health
- Open/short sensor diagnostics assist with detecting issues in the sensor loop
- Compensation for ambient temperatures enhances transmitter performance
- Four user-configurable alerts provide increased process information and measurement point insight (only available with enclosure option code P)

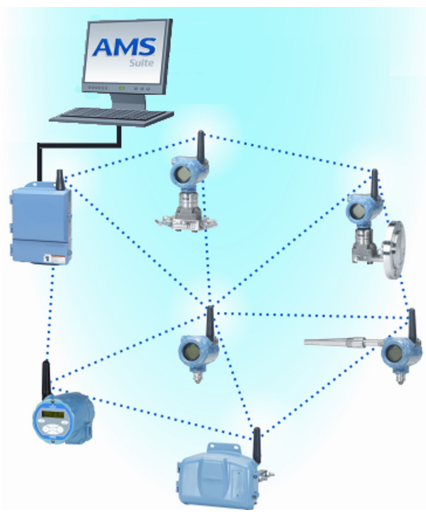

## Smart Wireless delivers innovative wireless solutions for temperature measurement and overall transmitter performance

- Self-organizing network delivers information rich data with >99% data reliability and establishes a highly stable network
- Smart Wireless capabilities extend the full benefits of PlantWeb™ to previously inaccessible temperature measurement locations
- Emerson SmartPower™ solutions provide an intrinsically safe Power Module, allowing field replacements without removing the transmitter from the process, keeping personnel safe and reducing maintenance costs
- Emerson Process Management’s layered approach to wireless network security ensures that data transmissions are secure

### Contents

Rosemount 248 Wireless Temperature Transmitter ... 2	Product Certifications ..... 12
Ordering Information ..... 4	Dimensional Drawings ..... 15
Specifications ..... 6	

## Explore the benefits of a Complete Point Solution from Rosemount Temperature Measurement

- An “Assemble To Sensor” option enables Emerson to provide a complete point temperature solution, delivering an installation-ready transmitter and sensor assembly
- Emerson offers a selection of RTDs, thermocouples, and thermowells that bring superior durability and Rosemount reliability to temperature sensing, complementing the Rosemount transmitter portfolio

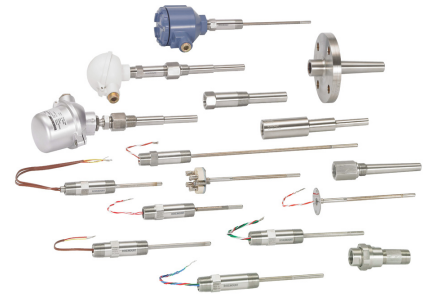

## Experience global consistency and local support from numerous worldwide Rosemount Temperature manufacturing sites



- World-class manufacturing provides globally consistent product from every factory and the capacity to fulfill the needs of any project, large or small
- Experienced Instrumentation Consultants help select the right product for any temperature application and advise on best installation practices
- An extensive global network of Emerson service and support personnel can be on-site when and where they are needed

- Make wireless installation and configuration easy with the **Emerson Smart Wireless Gateway**.
- For wireless applications that require superior accuracy, consider the **Rosemount 648 Wireless Temperature Transmitter**.
- Explore how Emerson's intrinsically safe **SmartPower Solutions** reduce maintenance costs.

## Ordering Information



The Rosemount 248 Wireless Temperature Transmitter has a rugged wireless transmitter design and industry-proven capabilities and specifications.

Transmitter features include:

- IEC-approved *WirelessHART* protocol (option code WA3)
- Large LCD display (option code M5)
- Internal antenna (option code WP5)
- 3-point calibration certificate (option code Q4)
- Assemble to Sensor options (option code XA)

**Table 1. Rosemount 248 Wireless Temperature Transmitter Ordering Information**

★ The Standard offering represents the most common options. The starred options (★) should be selected for best delivery. The Expanded offering is subject to additional delivery lead time.

Code	Product description				
248	Temperature transmitter				
<b>Transmitter type</b>					
D	Wireless field mount		★		
<b>Transmitter output</b>					
X	Wireless		★		
<b>Product certifications</b>					
NA	No Approval		★		
I5	USA Intrinsically Safe and Non-incendive		★		
N5 <sup>(1)</sup>	USA Nonincendive and Dust-Ignitionproof		★		
I6	Canada Intrinsically Safe		★		
I1	ATEX Intrinsic Safety		★		
I7	IECEx Intrinsic Safety		★		
I2 <sup>(2)</sup>	INMETRO Intrinsic Safety		★		
I4 <sup>(2)</sup>	TIIS Intrinsic Safety		★		
I3 <sup>(2)</sup>	NEPSI Intrinsic Safety		★		
IM	Technical Regulation Customs Union (EAC), Intrinsic Safety		★		
<b>Enclosure options</b>			<b>Material</b>	<b>IP rating</b>	
D	Wireless housing		Aluminum	IP66/67	★
P	Wireless engineered polymer housing		Engineered Polymer	IP66/67	★
<b>Conduit entry size</b>					
2	1/2–14 NPT				★

**Table 1. Rosemount 248 Wireless Temperature Transmitter Ordering Information**

★ The Standard offering represents the most common options. The starred options (★) should be selected for best delivery. The Expanded offering is subject to additional delivery lead time.

**Options (include with selected model number)**

<b>Assemble to options</b>		
NS	No sensor	★
XA <sup>(3)</sup>	Sensor specified separately and assembled to transmitter	★
<b>Wireless update rate, operating frequency, and protocol</b>		
WA3	User configurable update rate, 2.4GHz DSSS, <i>WirelessHART</i>	★
<b>Omnidirectional wireless antenna and SmartPower</b>		
WP5 <sup>(2)(4)</sup>	Internal antenna, compatible with green power module (I.S. power module sold separately)	★
WK1 <sup>(1)(5)</sup>	External antenna, adapter for black power module (I.S. power module sold separately)	★
<b>Mounting bracket</b>		
B5	Universal “L” mounting bracket for 2-in. pipe mounting – SST bracket and bolts	★
<b>Display<sup>(2)</sup></b>		
M5	LCD display	★
<b>Cable gland option</b>		
G2	Cable gland (7.5 mm to 11.9 mm)	★
G4	Thin wire cable gland (3 mm to 8 mm)	★
<b>5-point calibration<sup>(1)</sup></b>		
C4	5-point calibration (Requires the Q4 option code to generate a calibration certificate)	★
<b>Calibration certificate</b>		
Q4	Calibration certificate (3-point calibration)	★
<b>External ground<sup>(1)</sup></b>		
G1	External ground lug assembly	★
<b>Line filter</b>		
F5	50 Hz line voltage filter	★
F6	60 Hz line voltage filter	★
<b>Software configuration</b>		
C1	Custom configuration of date, descriptor, message, and wireless parameters (Requires CDS with order)	★
<b>Extended product warranty</b>		
WR3	3-year limited warranty	★
WR5	5-year limited warranty	★
<b>Typical model number: 248 D X NA P 2 NS WA3 WP5 B5 M5 F6 WR3</b>		

1. Only available with enclosure option code D.

2. Only available with enclosure option code P.

3. When ordering a Rosemount 248 Wireless with the XA option, a mounting bracket is not included. If a bracket is required, order option code B5.

4. Green power module must be shipped separately, order Model 701PGNKF.

5. Black power module must be shipped separately, order Model 701PBKKF.

# Specifications

## Functional specifications

### Input

Supports Thermocouple, RTD, millivolt, and ohm input types. See “Accuracy” on page 9 for a full listing of sensor options.

### Output

IEC 62591 (*WirelessHART*), 2.4 GHz DSSS

### Local display<sup>(1)</sup>

The optional five digit integral LCD display can display sensor temperature in engineering units (°F, °C, °R, K, Ω, and millivolts) and percent of range. The display updates based in the wireless update rate.

### Humidity limits

0–99% non-condensing relative humidity

### Update rate

*WirelessHART*, user-selectable 1 second to 60 minutes

### Accuracy (Pt 100 @ reference condition: 20 °C)

±0.81 °F (±0.45 °C)

### Wireless radio (WP5 and WK1 options)

Frequency: 2,400–2,485 GHz

Channels: 15

Modulation: IEEE 802.15.4 compliant DSSS

## Physical specifications

### Material selection

Emerson provides a variety of Rosemount product with various product options and configurations including materials of construction that can be expected to perform well in a wide range of applications. The Rosemount product information presented is intended as a guide for the purchaser to make an appropriate selection for the application. It is the purchaser’s sole responsibility to make a careful analysis of all process parameters (such as all chemical components, temperature, pressure, flow rate, abrasives, contaminants, etc.), when specifying product, materials, options and components for the particular application. Emerson Process Management is not in a position to evaluate or guarantee the compatibility of the process fluid or other process parameters with the product, options, configuration or materials of construction selected.

### Conformance to specifications ( $\pm 3\sigma$ [Sigma])

Technology leadership, advanced manufacturing techniques, and statistical process control ensure specification conformance to at least  $\pm 3\sigma$ .

### Electrical connections

#### Power module

The Emerson SmartPower power module is field replaceable, featuring keyed connections that eliminate the risk of incorrect installation.

The power module is an Intrinsically Safe solution, containing Lithium-thionyl chloride with a polybutadine terephthalate (PBT) enclosure.

The Rosemount 248 Wireless has a power module life time rating of 10 years with a one minute update rate at reference conditions.<sup>(2)</sup>

#### Sensor terminals

Sensor terminals permanently fixed to terminal block

1. Only available with enclosure option code P.

2. Reference conditions are 70 °F (21 °C), and routing data for three additional network devices.

Note: Continuous exposure to ambient temperature limits –40 °F or 185 °F (–40 °C or 85 °C) may reduce specified life by less than 20 percent.

## Field Communicator connections

### Communication terminals

HART® interface connections fixed to the power module (polymer housing)

Clips permanently fixed to terminal block, designated by the text “COMM” (aluminum housing)

### Materials of construction

#### Enclosure

Housing: PBT/PC or low-copper aluminum with NEMA® 4X and IP66/67

Paint: Polyurethane (aluminum housing)

Cover O-ring: Silicone (polymer housing),  
Buna-N (aluminum housing)

Conduit entry: 316 SST (polymer housing)

#### Antenna

PBT/PC integrated omni-directional antenna (aluminum housing)

### Mounting

Transmitters may be attached directly to the sensor. Mounting brackets also permit remote mounting. See “[Dimensional Drawings](#)” on page 15.

### Weight

#### Engineered polymer

248 without LCD display: 0.99 lb (0,45 kg)

248 with LCD display: 1.11 lb (0,51 kg)

#### Aluminum

3.03 lb (1,38 kg)

### Enclosure ratings

Type 4X and IP66/67

## Performance specifications

### Electromagnetic Compatibility (EMC)

Meets all relevant requirements of IEC 61326

### Transmitter measurement stability

±0.15% of output reading or 0.15 °C (whichever is greater) for 12 months

### Self calibration

The analog-to-digital measurement circuitry automatically self-calibrates for each temperature update by comparing the dynamic measurement to extremely stable and accurate internal reference elements.

### Vibration effect

The Rosemount 248 Wireless (direct and remote mounted with enclosure option code D and direct mounted with enclosure option code P) are tested to the following specifications with no effect on performance per IEC 60770-1, 1999:

Frequency	Acceleration
10–60 Hz	0.21 mm peak displacement
60–2000 Hz	3 g

The Rosemount 248 Wireless (remote mounted with enclosure option code P) is tested to the following specifications with no effect on performance per IEC 60770-1, 1999:

Frequency	Acceleration
10–60 Hz	0.15 mm peak displacement
60–500 Hz	2 g

Sensor connections

Figure 1. Rosemount 248 Wireless Sensor Terminal Block (Polymer Housing)

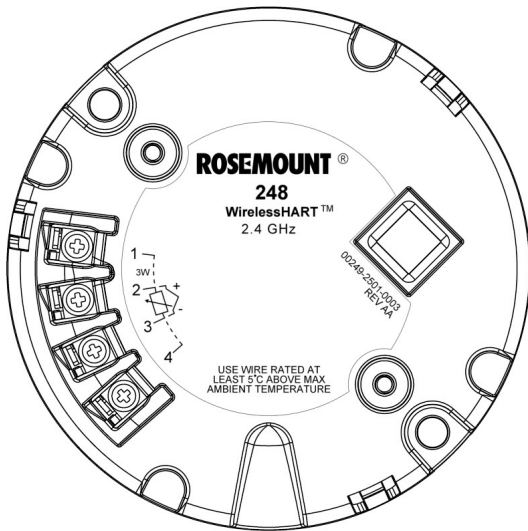

Figure 2. Rosemount 248 Wireless Sensor Terminal Block (Aluminum Housing)

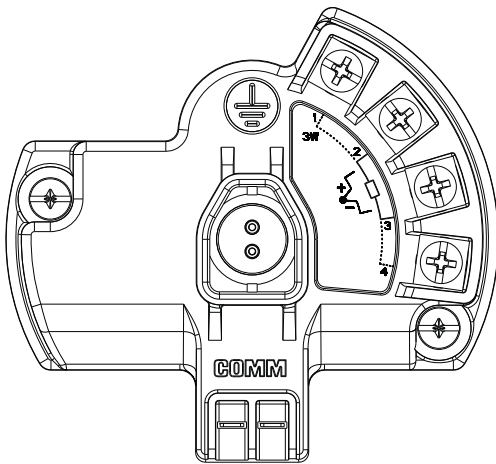
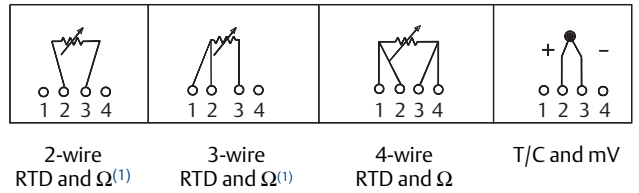

Figure 3. 248 Wireless Sensor Connection



- Emerson Process Management provides 4-wire sensors for all single element RTDs. You can use these RTDs in 3-wire or 2-wire configurations by leaving the unneeded leads disconnected and insulated with electrical tape.

Temperature limits

Operating limit	Storage limit
-40 to 185 °F (-40 to 85 °C)	-40 to 185 °F (-40 to 85 °C)

## Accuracy

Table 2. Rosemount 248 Wireless Input Options and Accuracy

Sensor options	Sensor reference	Input ranges		Digital accuracy <sup>(1)</sup>	
		°C	°F	°C	°F
<b>2-, 3-, 4-wire RTDs</b>					
Pt 100 ( $\alpha = 0.00385$ )	IEC 751	-200 to 850	-328 to 1562	±0.45	±0.81
Pt 200 ( $\alpha = 0.00385$ )	IEC 751	-200 to 850	-328 to 1562	±0.45	±0.81
Pt 500 ( $\alpha = 0.00385$ )	IEC 751	-200 to 850	-328 to 1562	±0.57	±1.026
Pt 1000 ( $\alpha = 0.00385$ )	IEC 751	-200 to 300	-328 to 572	±0.57	±1.026
Pt 100 ( $\alpha = 0.003916$ )	JIS 1604	-200 to 645	-328 to 1193	±0.45	±0.81
Pt 200 ( $\alpha = 0.003916$ )	JIS 1604	-200 to 645	-328 to 1193	±0.45	±0.81
Ni 120	Edison Curve No. 7	-70 to 300	-94 to 572	±0.45	±0.81
Cu 10	Edison Copper Winding No. 15	-50 to 250	-58 to 482	±4.16	±7.488
Pt 50 ( $\alpha = 0.00391$ )	GOST 6651-94	-200 to 550	-328 to 990	±0.9	±1.62
Pt 100 ( $\alpha = 0.00391$ )	GOST 6651-94	-200 to 550	-328 to 990	±0.45	±0.81
Cu 50 ( $\alpha = 0.00426$ )	GOST 6651-94	-50 to 200	-58 to 392	±1.44	±2.592
Cu 50 ( $\alpha = 0.00428$ )	GOST 6651-94	-185 to 200	-301 to 392	±1.44	±2.592
Cu 100 ( $\alpha = 0.00426$ )	GOST 6651-94	-50 to 200	-58 to 392	±0.72	±1.296
Cu 100 ( $\alpha = 0.00428$ )	GOST 6651-94	-185 to 200	-301 to 392	±0.72	±1.296
<b>Thermocouples<sup>(2)</sup></b>					
Type B <sup>(3)</sup>	NIST Monograph 175, IEC 584	100 to 1820	212 to 3308	±2.25	±4.05
Type E	NIST Monograph 175, IEC 584	-50 to 1000	-58 to 1832	±0.60	±1.08
Type J	NIST Monograph 175, IEC 584	-180 to 760	-292 to 1400	±1.05	±1.89
Type K <sup>(4)</sup>	NIST Monograph 175, IEC 584	-180 to 1372	-292 to 2501	±1.46	±2.628
Type N	NIST Monograph 175, IEC 584	-200 to 1300	-328 to 2372	±1.46	±2.628
Type R	NIST Monograph 175, IEC 584	0 to 1768	-32 to 3214	±2.25	±4.05
Type S	NIST Monograph 175, IEC 584	0 to 1768	-32 to 3214	±2.1	±3.78
Type T	NIST Monograph 175, IEC 584	-200 to 400	-328 to 752	±1.05	±1.89
DIN Type L	DIN 43710	-200 to 900	-328 to 1652	±1.05	±1.89
DIN Type U	DIN 43710	-200 to 600	-328 to 1112	±1.05	±1.89
Type W5Re/W26Re	ASTM E 988-96	0 to 2000	-32 to 3632	±2.1	±3.78
GOST Type L	GOST R 8.585-2001	-200 to 800	-328 to 1472	±1.80	±3.24
<b>Other sensor types</b>					
Millivolt input		-10 to 100 mV		±0.045 mV	
2-, 3-, 4-wire ohm input		0 to 2000 ohms		±1.35 ohm	

1. The published digital accuracy applies over the entire sensor input range. Digital output can be accessed by HART Communications or wireless protocol.
2. Total digital accuracy for thermocouple measurement: sum of digital accuracy +0.8 °C (cold junction accuracy).
3. Digital accuracy for NIST Type B T/C is ±16.2 °F (± 9.0 °C) from 212 to 572 °F (100 to 300 °C).
4. Digital accuracy for NIST Type K T/C is ± 35.79 °F (± 2.1 °C) from -292 to -130 °F (-180 to -90 °C).

## Ambient temperature effect

Table 3. Rosemount 248 Wireless Ambient Temperature Effect

Sensor options	Sensor reference	Input range (°C)	Temperature effects per 1.0 °C (1.8 °F) change in ambient temperature <sup>(1)(2)</sup>	Range
<b>2-, 3-, 4-wire RTDs</b>				
Pt 100 ( $\alpha = 0.00385$ )	IEC 751	-200 to 850	0.009 °C (0.0162 °F)	Entire sensor input range
Pt 200 ( $\alpha = 0.00385$ )	IEC 751	-200 to 850	0.012 °C (0.0216 °F)	Entire sensor input range
Pt 500 ( $\alpha = 0.00385$ )	IEC 751	-200 to 850	0.009 °C (0.0162 °F)	Entire sensor input range
Pt 1000 ( $\alpha = 0.00385$ )	IEC 751	-200 to 300	0.009 °C (0.0162 °F)	Entire sensor input range
Pt 100 ( $\alpha = 0.003916$ )	JIS 1604	-200 to 645	0.009 °C (0.0162 °F)	Entire sensor input range
Pt 200 ( $\alpha = 0.003916$ )	JIS 1604	-200 to 645	0.012 °C (0.0216 °F)	Entire sensor input range
Ni 120	Edison Curve No. 7	-70 to 300	0.009 °C (0.0162 °F)	Entire sensor input range
Cu 10	Edison Copper Winding No. 15	-50 to 250	0.06 °C (0.162 °F)	Entire sensor input range
Pt 50 ( $\alpha = 0.003910$ )	GOST 6651-94	-200 to 550	0.018 °C (0.0324 °F)	Entire sensor input range
Pt 100 ( $\alpha = 0.003910$ )	GOST 6651-94	-200 to 550	0.009 °C (0.0162 °F)	Entire sensor input range
Cu 50 ( $\alpha = 0.00426$ )	GOST 6651-94	-50 to 200	0.012 °C (0.0216 °F)	Entire sensor input range
Cu 50 ( $\alpha = 0.00428$ )	GOST 6651-94	-185 to 200	0.012 °C (0.0216 °F)	Entire sensor input range
Cu 100 ( $\alpha = 0.00426$ )	GOST 6651-94	-50 to 200	0.009 °C (0.0162 °F)	Entire sensor input range
Cu 100 ( $\alpha = 0.00428$ )	GOST 6651-94	-185 to 200	0.009 °C (0.0162 °F)	Entire sensor input range
<b>Thermocouples</b>				
Type B	NIST Monograph 175, IEC 584	100 to 1820	0.0435 °C	$T \geq 1000$ °C
			$0.096$ °C - (0.0075% of [T - 300])	$300$ °C $\leq T < 1000$ °C
			$0.162$ °C - (0.033% of [T - 100])	$100$ °C $\leq T < 300$ °C
Type E	NIST Monograph 175, IEC 584	-50 to 1000	$0.015$ °C + (0.00129% of absolute value T)	All
Type J	NIST Monograph 175, IEC 584	-180 to 760	$0.0162$ °C + (0.00087% of T)	$T \geq 0$ °C
			$0.0162$ °C + (0.0075% of absolute value T)	$T < 0$ °C
Type K	NIST Monograph 175, IEC 584	-180 to 1372	$0.0183$ °C + (0.0027% of T)	$T \geq 0$ °C
			$0.0183$ °C + (0.0075% of absolute value T)	$T < 0$ °C

**Table 3. Rosemount 248 Wireless Ambient Temperature Effect**

<b>Thermocouples</b>				
Type N	NIST Monograph 175, IEC 584	-200 to 1300	0.0204 °C + (0.00108% of absolute value T)	All
Type R	NIST Monograph 175, IEC 584	0 to 1768	0.048 °C	T ≥ 200 °C
			0.069 °C – (0.0108% of T)	T < 200 °C
Type S	NIST Monograph 175, IEC 584	0 to 1768	0.048 °C	T ≥ 200 °C
			0.069 °C – (0.0108% of T)	T < 200 °C
Type T	NIST Monograph 175, IEC 584	-200 to 400	0.0192 °C	T ≥ 0 °C
			0.0192 °C + (0.0129% of absolute value T)	T < 0 °C
DIN Type L	DIN 43710	-200 to 900	0.0162 °C + (0.00087% of T)	T ≥ 0 °C
			0.0162 °C + (0.0075% of absolute value T)	T < 0 °C
DIN Type U	DIN 43710	-200 to 900	0.0192 °C	T ≥ 0 °C
			0.0192 °C + (0.0129% of absolute value T)	T < 0 °C
Type W5Re/W26Re	ASTM E 988-96	0 to 2000	0.048 °C	T ≥ 200 °C
			0.069 °C – (0.0108% of T)	T < 200 °C
GOST Type L	GOST R 8.585-2001	-200 to 800	0.021 °C	T ≥ 0 °C
			0.0105 °C + (0.0045% of absolute value T)	T < 0 °C
<b>Other sensor types</b>				
Millivolt input		-10 to 100 mV	0.0015 mV	Entire sensor input range
2-, 3-, 4-wire ohm		0 to 2000 W	0.0252 W	Entire sensor input range

1. Change in ambient is with reference to the calibration temperature of the transmitter 68 °F (20 °C) from factory.
2. Ambient temperature effect specification valid over minimum temperature span of 50 °F (28 °C).

Transmitters can be installed in locations where the ambient temperature is between -40 and 185 °F (-40 and 85 °C). In order to maintain excellent accuracy performance, each transmitter is individually characterized over this ambient temperature range at the factory.

**Temperature effects example**

When using a Pt 100 ( $\alpha = 0.00385$ ) sensor input at 30 °C ambient temperature:

- Digital temperature effects:  $0.009\text{ °C} \times (30 - 20) = 0.09\text{ °C}$
- Worst case error: Digital + Digital temperature effects =  $0.45\text{ °C} + 0.09\text{ °C} = 0.54\text{ °C}$
- Total probable error:  $\sqrt{0.45^2 + 0.09^2} = 0.459\text{ °C}$

# Product Certifications

Rev 1.5

## European Directive Information

A copy of the EC Declaration of Conformity can be found at the end of the Quick Start Guide. The most recent revision of the EC Declaration of Conformity can be found at

[EmersonProcess.com/Rosemount](http://EmersonProcess.com/Rosemount).

## Ordinary Location Certification

As standard, the transmitter has been examined and tested to determine that the design meets the basic electrical, mechanical, and fire protection requirements by a nationally recognized test laboratory (NRTL) as accredited by the Federal Occupational Safety and Health Administration (OSHA).

## Telecommunication Compliance

All wireless devices require certification to ensure that they adhere to regulations regarding the use of the RF spectrum. Nearly every country requires this type of product certification. Emerson is working with governmental agencies around the world to supply fully compliant products and remove the risk of violating country directives or laws governing wireless device usage.

## FCC and IC

This device complies with Part 15 of the FCC Rules. Operation is subject to the following conditions: This devices may not cause harmful interference, this devices must accept any interference received, including interference that may cause undesired operation. This device must be installed to ensure a minimum antenna separation distance of 20 cm from all persons.

## Installing Equipment in North America

The US National Electrical Code® (NEC) and the Canadian Electrical Code (CEC) permit the use of Division marked equipment in Zones and Zone marked equipment in Divisions. The markings must be suitable for the area classification, gas, and temperature class. This information is clearly defined in the respective codes.

## USA

- I5** USA Intrinsically Safe  
 Certificate: 70008071 (Polymer housing)  
 Standards: FM 3600:2011; FM 3610:2010;  
 FM 3611:2004; UL 61010-1:2012;  
 UL 50E:2012; ANSI/IEC 60529:2004  
 Markings: Intrinsically Safe: CL I, DIV 1, GP A, B, C, D;  
 CL I, DIV 2, GP A, B, C, D;  
 Class I, Zone 0, AEx ia IIC T4/T5 Ga;  
 T4(-50 °C ≤ T<sub>a</sub> ≤ +70 °C);  
 T5(-50 °C ≤ T<sub>a</sub> ≤ +40 °C); when installed per  
 Rosemount drawing 00249-2020; Type 4X,  
 IP66/67  
 See [Table 4](#) at the end of the Product  
 Certifications section for Entity Parameters.

### **Special Condition for Safe Use (X):**

- Battery Exchange: The battery module can be change inside hazardous gas-explosive locations. During battery change it must be assured that the connections are free from dust or dirt.
- I5** USA Intrinsically Safe  
 Certificate: 3039717 (Aluminum housing)  
 Standards: FM Class 3600:1998; FM Class 3610:2010;  
 FM Class 3611:2004; FM Class 3810:2005;  
 ANSI/NEMA 250:2003; ANSI/IEC 60529:2004  
 Markings: IS CL I/II/III, DIV 1, GP A, B, C, D, E, F, G;  
 IS CL I, Zone 0, AEx ia IIC; NI CL I, DIV 2,  
 GP A, B, C, D; T4(-50 °C ≤ T<sub>a</sub> ≤ +70 °C),  
 T5(-50 °C ≤ T<sub>a</sub> ≤ +40 °C) when installed per  
 Rosemount drawing 00249-1000; Type 4X;  
 IP66/67  
 See [Table 4](#) at the end of the Product  
 Certifications section for Entity Parameters.
- N5** USA Nonincendive and Dust-Ignitionproof  
 Certificate: 3039717 (Aluminum housing)  
 Standards: FM Class 3600:1998; FM Class 3611:2004;  
 FM Class 3810:2005; ANSI/NEMA 250: 2003;  
 ANSI/IEC 60529: 2004  
 Markings: NI CL I, DIV 2, GP A, B, C, D;  
 T4(-50 °C ≤ T<sub>a</sub> ≤ +70 °C);  
 DIP CL II/III, DIV 1, GP E, F, G;  
 -50 °C ≤ T<sub>a</sub> ≤ +85 °C; when installed per  
 Rosemount drawing 00249-1000; Type 4X;  
 IP66/67

## Canada

- 16** Canada Intrinsically Safe  
 Certificate: 70008071 (Polymer housing)  
 Standards: CSA C22.2 No. 0-10;  
 CSA C22.2 No. 94.2-07 (R2012);  
 CSA C22.2 No. 213-M1987 (R2013);  
 CAN/CSA-60079-0-11;  
 CAN/CSA-60079-11-14;  
 CAN/CSA C22.2 No. 60529-05;  
 CAN/CSA-C22.2 No. 61010-1-12  
 Markings: Intrinsically Safe: CL I, DIV 1, GP A, B, C, D;  
 CL I, DIV 2, GP A, B, C, D; Ex ia IIC T4/T5 Ga;  
 T4(-50 °C ≤ T<sub>a</sub> ≤ +70 °C);  
 T5(-50 °C ≤ T<sub>a</sub> ≤ +40 °C) when installed per  
 Rosemount drawing 00249-2020; Type 4X,  
 IP66/67  
 See [Table 4](#) at the end of the Product  
 Certifications section for Entity Parameters.

### **Special Condition for Safe Use (X):**

- Battery Exchange: The battery module can be change inside hazardous gas-explosive locations. During battery change it must be assured that the connections are free from dust or dirt.
- 16** Canada Intrinsically Safe  
 Certificate: 1091070 (Aluminum housing)  
 Standards: CAN/CSA C22.2 No. 0-10;  
 CSA Std. C22.2 No. 25-1966;  
 CAN/CSA C22.2 No. 94-M91;  
 CAN/CSA C22.2 No. 157-92;  
 CSA C22.2 No. 213-M1987;  
 C22.2 No. 60529-05;  
 CSA Std. C22.2 No. 142-M1987  
 Markings: Intrinsically Safe: CL I, DIV 1 GP A, B, C, D;  
 Suitable for use in CL I DIV 2 GP A, B, C, D; T3C;  
 when installed per Rosemount drawing  
 00249-1020; Type 4X, IP66/67  
 See [Table 4](#) at the end of the Product  
 Certifications section for Entity Parameters.

## Europe

- 11** ATEX Intrinsic Safety  
 Certificate: Baseefa14ATEX0359X (Polymer housing)  
 Standards: EN 60079-0:2012; EN 60079-11:2012  
 Markings: Ⓔ II 1 G Ex ia IIC T4/T5 Ga;  
 T4(-60 °C ≤ T<sub>a</sub> ≤ +70 °C);  
 T5(-60 °C ≤ T<sub>a</sub> ≤ +40 °C)  
 See [Table 4](#) at the end of the Product  
 Certifications section for Entity Parameters.

### **Special Condition for Safe Use (X):**

- The plastic enclosure may present a potential electrostatic ignition hazard and must not be rubbed or cleaned with a dry cloth.
- 11** ATEX Intrinsic Safety  
 Certificate: Baseefa10ATEX0121X (Aluminum housing)  
 Standards: EN 60079-0:2009; EN 60079-11:2007  
 Markings: Ⓔ II 1 G Ex ia IIC T4/T5 Ga,  
 T4(-60 °C ≤ T<sub>a</sub> ≤ +70 °C),  
 T5(-60 °C ≤ T<sub>a</sub> ≤ +40 °C);  
 See [Table 4](#) at the end of the Product  
 Certifications section for Entity Parameters

### **Special Conditions for Safe Use (X):**

- The plastic antenna may present a potential electrostatic ignition hazard and must not be rubbed or cleaned with a dry cloth.
- The Rosemount 248 enclosure may be made of aluminum alloy and given a protective polyurethane paint finish; however, care should be taken to protect it from impact or abrasion if located in a Zone 0 area.

## International

- I7** IECEx Intrinsic Safety  
 Certificate: IECEx BAS 14.0158X (Polymer housing)  
 Standards: IEC 60079-0:2011; IEC 60079-11:2011  
 Markings: Ex ia IIC T4/T5 Ga, T4(-60 °C ≤ T<sub>a</sub> ≤ +70 °C),  
 T5(-60 °C ≤ T<sub>a</sub> ≤ +40 °C);  
 See [Table 4](#) at the end of the Product  
 Certifications section for Entity Parameters.

**Special Condition for Safe Use (X):**

- The plastic enclosure may present a potential electrostatic ignition hazard and must not be rubbed or cleaned with a dry cloth.
- I7** IECEx Intrinsic Safety  
 Certificate: IECEx BAS 10.0059X (Aluminum housing)  
 Standards: IEC 60079-0:2011; IEC 60079-11:2011  
 Markings: Ex ia IIC T4/T5 Ga, T4(-60 °C ≤ T<sub>a</sub> ≤ +70 °C),  
 T5(-60 °C ≤ T<sub>a</sub> ≤ +40 °C);  
 See [Table 4](#) at the end of the Product  
 Certifications section for Entity Parameters.

**Special Conditions for Safe Use (X):**

- The surface resistivity of the antenna is greater than 1GΩ. To avoid electrostatic charge build-up, it must not be rubbed or cleaned with solvents or a dry cloth.
- The Rosemount 701PBKKF Power Module and Intelligent Power Module 71008 may be replaced in a hazardous area. The Power Modules have a surface resistivity greater than 1GΩ and must be properly installed in the wireless device enclosure. Care must be taken during transportation to and from the point of installation to prevent electrostatic charge build-up.
- The Rosemount 248 enclosure may be made of aluminum alloy and given a protective polyurethane paint finish; however, care should be taken to protect it from impact or abrasion if located in a Zone 0 area.

## Brazil

- I2** INMETRO Intrinsic Safety  
 Certificate: UL-BR 15.0222X (Polymer housing)  
 Standards: ABNT NBR IEC 60079-0: 2008 + Corrigendum 1:2011; ABNT NBR IEC 60079-11:2009  
 Markings: Ex ia IIC T4/T5 Ga; T4 (-60 °C ≤ T<sub>a</sub> ≤ +70 °C);  
 T5 (-60 °C ≤ T<sub>a</sub> ≤ +40 °C)  
 See [Table 4](#) at the end of the Product  
 Certifications section for Entity Parameters.

**Special Condition for Safe Use (X):**

- The plastic enclosure may present a potential electrostatic ignition hazard and must not be rubbed or cleaned with a dry cloth.

## China

- I3** NEPSI Intrinsic Safety  
 Certificate: GYJ15.1143X (Polymer housing)  
 Standards: GB3836.1-2010, GB3836.4-2010,  
 GB3836.20-2010  
 Markings: Ex ia IIC T4/T5 Ga; T4 (-60 °C ≤ T<sub>a</sub> ≤ +70 °C);  
 T5 (-60 °C ≤ T<sub>a</sub> ≤ +40 °C)  
 See [Table 4](#) at the end of the Product  
 Certifications section for Entity Parameters.

**Special Conditions for Safe Use (X):**

- Non-metallic parts incorporated in the enclosure of the product shall only be cleaned with a damp cloth to avoid electrostatic charge.
- Must use Rosemount 701PGNKF SmartPower Green Power Module provided by the manufacture.

## Japan

- I4** TIIS Intrinsic Safety  
 Certificate: TC21031 (Polymer housing)  
 Markings: Ex ia IIC T4 X (-20 °C ~ +60 °C)  
 See [Table 4](#) at the end of the Product  
 Certifications section for Entity Parameters.

## EAC

- IM** Technical Regulation Customs Union (EAC) Intrinsic Safety  
 Certificate: TC RU C-US.AA87.B.00057  
 Markings: 0Ex ia IIC T4, T5 Ga X, T5(-60 °C ≤ T<sub>a</sub> ≤ +40 °C),  
 T4(-60 °C ≤ T<sub>a</sub> ≤ +70 °C); IP66/IP67

**Special Condition for Safe Use (X):**

- See certificate for special conditions.

## Tables

**Table 4. Entity Parameters**

Parameters	USA, ATEX, IECEx, and Canada (Polymer)	Canada (Aluminum)
Voltage U <sub>o</sub>	6.6 V	6.6 V
Current I <sub>o</sub>	26.2 mA	26.2 mA
Power P <sub>o</sub>	42.6 mW	42.6 mW
Capacitance C <sub>o</sub>	11 μF	23.8 μF
Inductance L <sub>o</sub>	25 mH	25 mH

# Dimensional Drawings

**Figure 4. Rosemount 248 Wireless Remote Mount (Polymer Housing)**

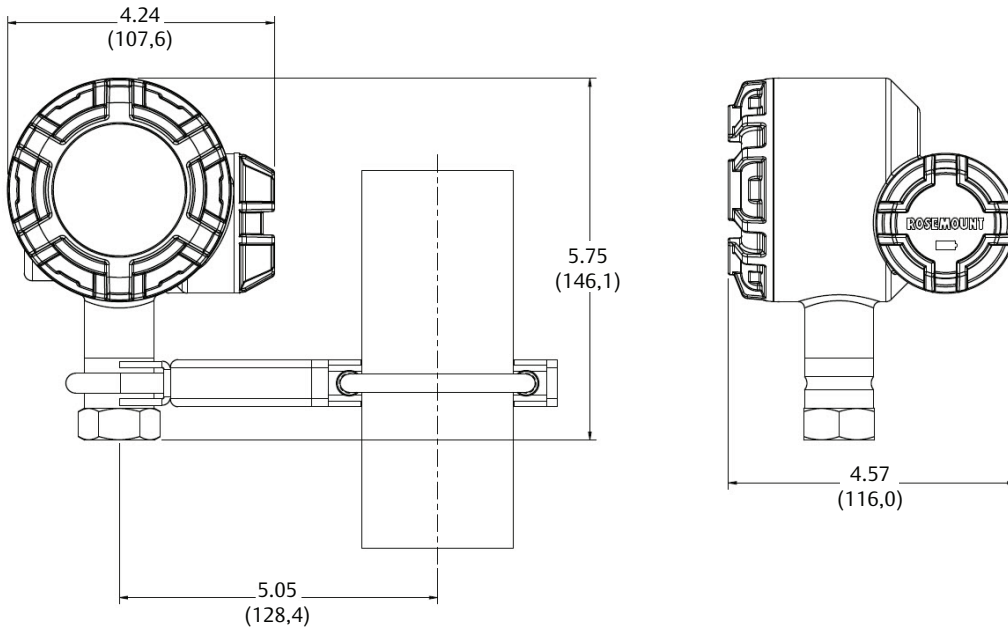

Dimensions are in inches (millimeters).

**Figure 5. Rosemount 248 Wireless Direct Mount (Polymer Housing)**

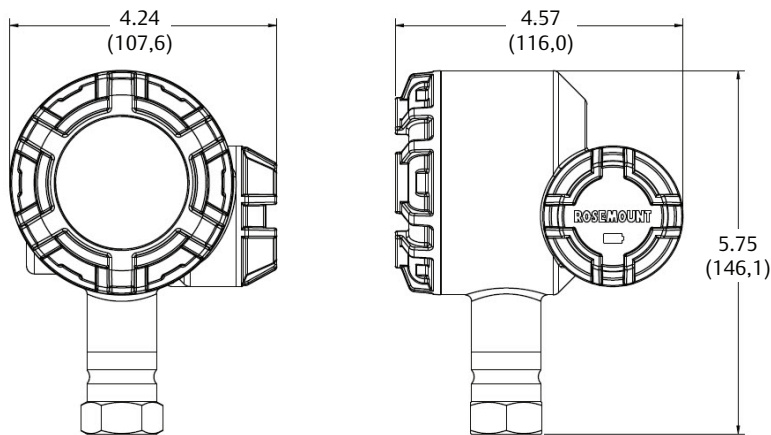

Dimensions are in inches (millimeters).

**Figure 6. Rosemount 248 Wireless Remote Mount (Aluminum Housing)**

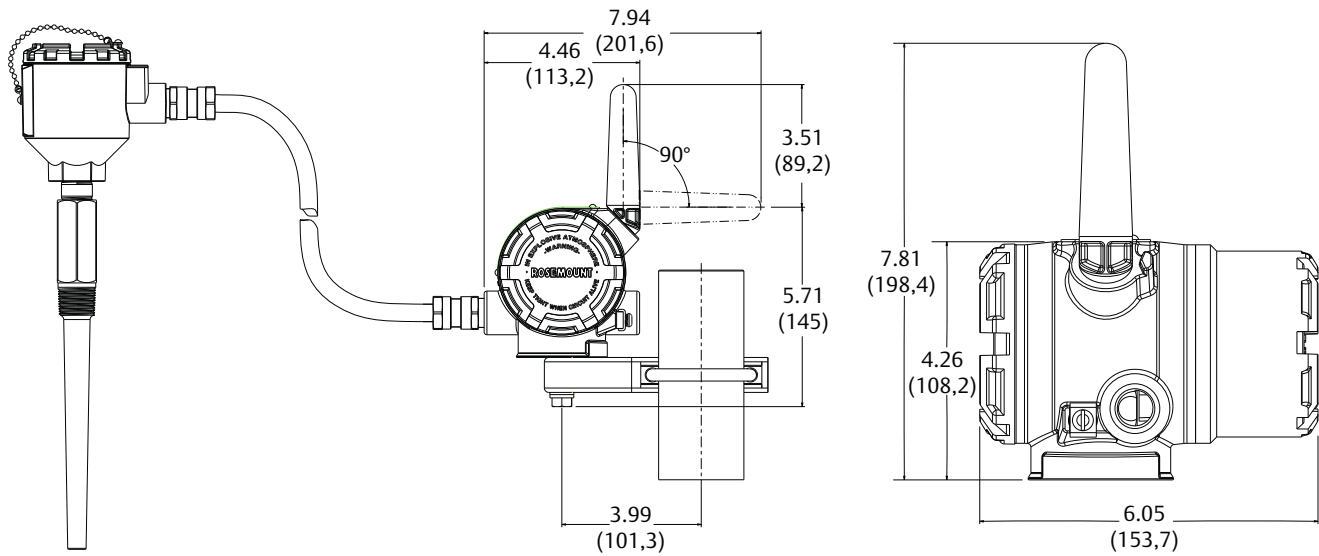

Remote mounted temperature sensor specified separately.  
Dimensions are in inches (millimeters).

**Figure 7. Rosemount 248 Wireless Direct Mount (Aluminum Housing)**

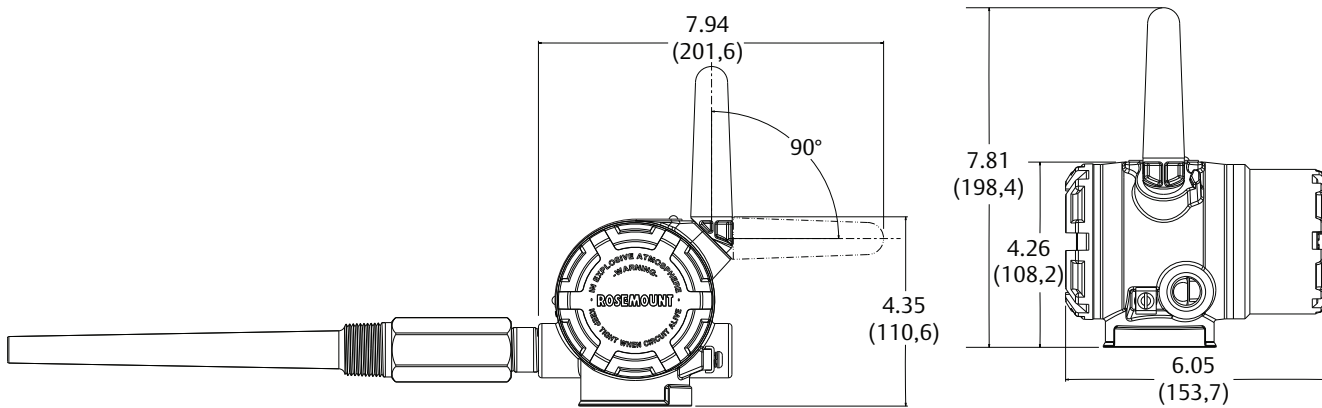

Direct mounted temperature sensor specified separately (see ordering option code XA).  
Dimensions are in inches (millimeters).



## Global Headquarters

### Emerson Process Management

6021 Innovation Blvd.  
Shakopee, MN 55379, USA  
+1 800 999 9307 or +1 952 906 8888  
+1 952 949 7001  
RFQ.RMD-RCC@EmersonProcess.com

## North America Regional Office

### Emerson Process Management

8200 Market Blvd.  
Chanhassen, MN 55317, USA  
+1 800 999 9307 or +1 952 906 8888  
+1 952 949 7001  
RMT-NA.RCCRFQ@Emerson.com

## Latin America Regional Office

### Emerson Process Management

1300 Concord Terrace, Suite 400  
Sunrise, FL 33323, USA  
+1 954 846 5030  
+1 954 846 5121  
RFQ.RMD-RCC@EmersonProcess.com

## Europe Regional Office

### Emerson Process Management Europe GmbH

Neuhofstrasse 19a P.O. Box 1046  
CH 6340 Baar  
Switzerland  
+41 (0) 41 768 6111  
+41 (0) 41 768 6300  
RFQ.RMD-RCC@EmersonProcess.com

## Asia Pacific Regional Office

### Emerson Process Management Asia Pacific Pte Ltd

1 Pandan Crescent  
Singapore 128461  
+65 6777 8211  
+65 6777 0947  
Enquiries@AP.EmersonProcess.com

## Middle East and Africa Regional Office

### Emerson Process Management

Emerson FZE P.O. Box 17033,  
Jebel Ali Free Zone - South 2  
Dubai, United Arab Emirates  
+971 4 8118100  
+971 4 8865465  
RFQ.RMTMEA@Emerson.com

 [Linkedin.com/company/Emerson-Process-Management](https://www.linkedin.com/company/Emerson-Process-Management)

 [Twitter.com/Rosemount\\_News](https://twitter.com/Rosemount_News)

 [Facebook.com/Rosemount](https://www.facebook.com/Rosemount)

 [Youtube.com/user/RosemountMeasurement](https://www.youtube.com/user/RosemountMeasurement)

 [Google.com/+RosemountMeasurement](https://www.google.com/+RosemountMeasurement)

Standard Terms and Conditions of Sale can be found at:

[www.Emerson.com/en-us/pages/Terms-of-Use.aspx](http://www.Emerson.com/en-us/pages/Terms-of-Use.aspx)

The Emerson logo is a trademark and service mark of Emerson Electric Co. Complete Point Solutions, PlantWeb, SmartPower, Rosemount, and Rosemount logotype are trademarks of Emerson Process Management. HART and *Wireless*HART are registered trademarks of FieldComm Group. NEMA is a registered trademark and service mark of the National Electrical Manufacturers Association. National Electrical Code is a registered trademark of National Fire Protection Association, Inc.

All other marks are the property of their respective owners.  
© 2016 Emerson Process Management. All rights reserved.