

VCF, VCS, VCR & HCP

Percentage Timing Input Controllers



- Motor Driven Cycling Device, 115 & 230 Vac
- 50/60 Hz, 20 & 25 Amp Capacity
- 50/60 Hz, 60 Amp Capacity (HCP only)
- 15 & 30 Second Cycles

VCF
Flush mounted controller for indoor use, UL Listed.

Applications

- Processes requiring exact replication of heat pulses.
- Varying work loads
- Conveyors
- Radiant heat control

Features

Percentage timing can be set to energize a heater for a chosen percentage (4-100%) of a preset 15 or 30 second cycle, thus derating heat output to match varying work sizes, loads or conveyor speeds.

Settings are repeatable between instruments and provide constant percentage of heat output.

WARNING: Hazard of Fire. These devices function as energy controls only. Because they do not fail-safe, an approved temperature and/or pressure safety control must be used for safe operation.

VCS
Surface mounted controller for indoor use, UL Listed.

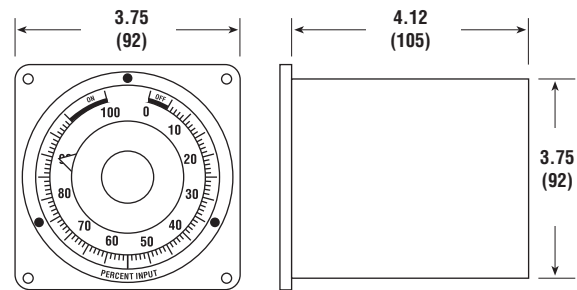

Front View

Side View

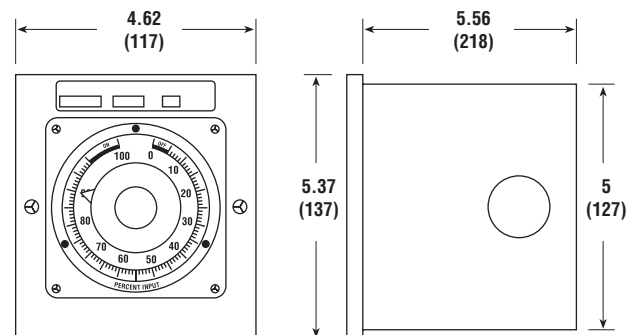

Front View

Side View

All Dimensions in Inches (mm)

VCF, VCS, VCR & HCP Percentage Timing Input Controllers (cont'd.)



VCR

Pre-wired input controller panel includes combination of input controller, pilot lights, fuse blocks and line switch to simplify heater and contactor wiring.

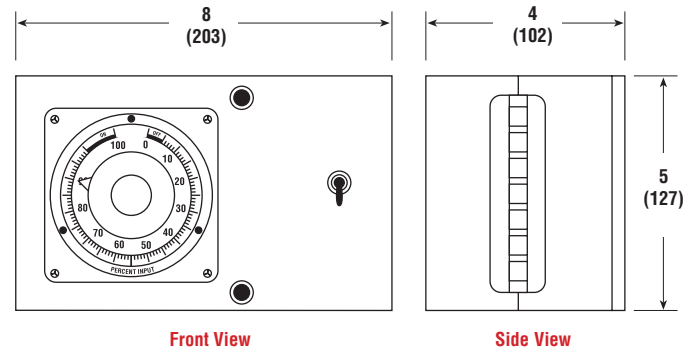

Timer Panel New HCP (309905)

Completely wired mechanical control package for infinitely varying radiant heater output. The heavy gauge metal enclosure includes a door-mounted input controller, indicator lights and ON/OFF switch for the control circuit. Panel mounted inside is a 3-pole magnetic contactor for power interruption, a voltage step-down transformer to provide 120 Vac to the control circuit from a 240 or 480 Vac power supply, and a 2-pole fuse block to protect the transformer. The HCP can be used to control either single or 3-phase loads. PCN 309905

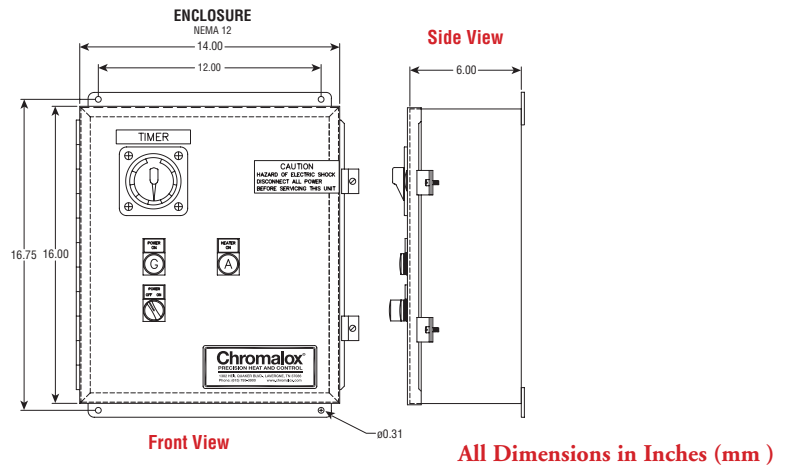

Specifications and Ordering Information

Time Cycle Sec.	Volts Mtr.	Capacity Amps	Type of Mtg.	Model	Stock	PCN	Wt. (Lbs.)
30	115	25	Flush	VCF-401A	S	114340	3-3/4
15	115	25	Flush	VCF-401A-15	S	114390	3-3/4
30	230	20 ²	Flush	VCF-402A	S	114358	3-3/4
15	230	20 ²	Flush	VCF-402A-15	S	114403	3-3/4
30	115	25	Surface	VCS-401A	S	112117	3-3/4
15	115	25	Surface	VCS-401A-15	S	114374	3-3/4
30	230	20 ²	Surface	VCS-402A	S	112125	3-3/4
15	230	20 ²	Surface	VCS-402A-15	S	114382	3-3/4
30	115	25	Surface	VCR-115	S	112168	5
30	230	20	Surface	VCR-230	S	112176	6
30	120	60 ³	Surface	4439-23006	S	309905	30

Stock Status: S = stock

Notes —

- When used on 50 Hz, standard units will provide 36 second cycle instead of 30, or 18 second cycle instead of 15.
- 25 Amps permissible on 230V but not UL.
- Contactors capacity.