

Edge-Cutter® Roof De-Icing System

- Aluminium Construction
- Angled or Flat Surface Designs
- Corrosion Resistant Coating Available

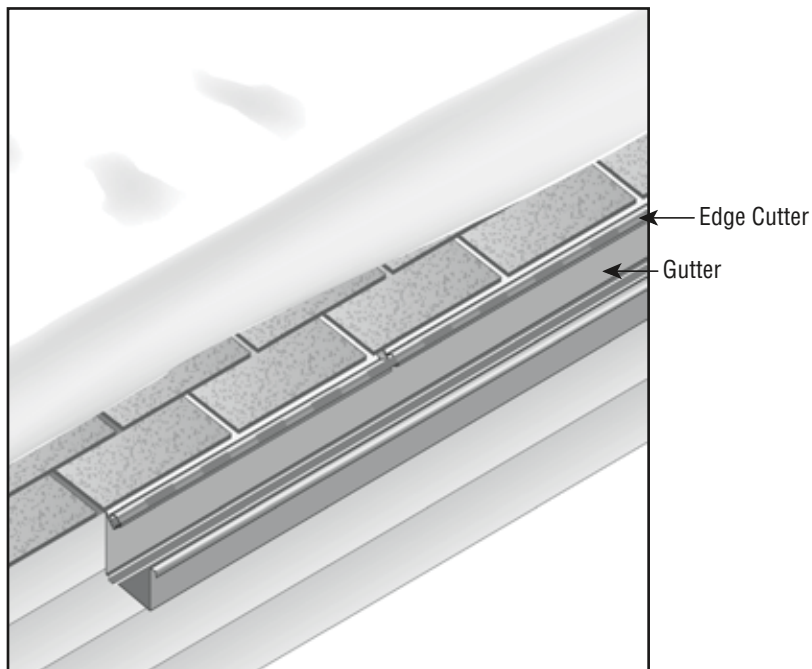

Description

Edge-Cutter® is an aluminum flashing designed to be used as a heat conductive plate to aid in keeping snow and ice from roof edges. The system is for use only with self-regulating heating cables certified for use in roof and gutter applications.

Edge-Cutter is designed to be applied between the roofing and the roof substrate. It can be used with various roofing products such as asphalt shingles, aluminum, steel* and even slate.

Valleys on a roof may also be heat traced with Edge-Cutter PLD-ECF (Flat Flashing).

Edge-Cutter can be fastened using various methods including screws or adhesives depending on application and building materials.

*Edge-Cutter can be ordered with a 6 mil urethane membrane applied to help prevent galvanic oxidation or corrosion when in contact with dissimilar metals.

Available Items

Model	PCN	Stock	Length	Wt (Lbs.)
PLD-EC*	393967	S	4'	1
PLD-ECF*	393975	S	4'	1
Cover-EC	393983	S	4'	1

* When ordering, cover is included with these models

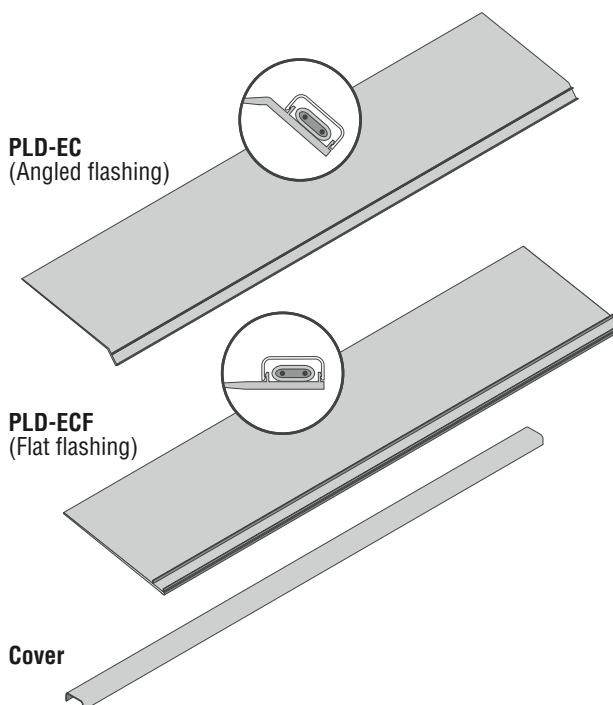

SNOW MELTING
CONTROLS

Edge-Cutter[®] Roof De-Icing System

(cont'd.)

Valleys can also be heat traced using Edge-Cutter PLD-ECF flat flashing. Dual or single flashing can be used in the valleys

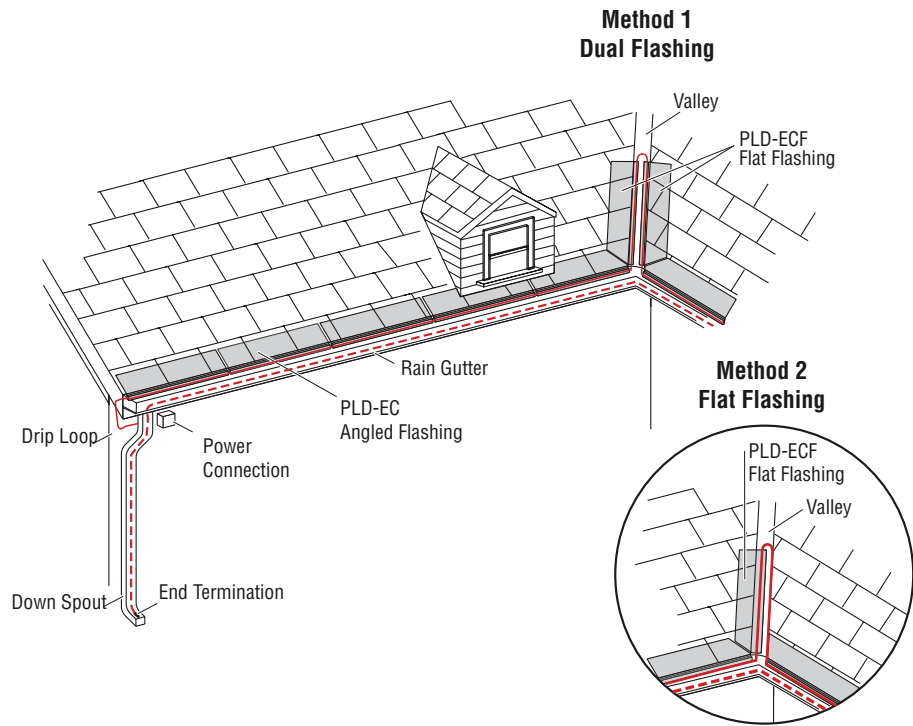

Edge-Cutter flashing can be cut to fit your specific roofing layout. Screws or adhesive can be used to easily attach the Edge-Cutter system to your roof.

