

LN & LW

Infrared Oven Section Heater Assemblies

- 0.5 - 2.25 kW/Ft²
- 0.45 - 3.8 kW
- 120, 208, 240, 480 and 575 Volt
- Metal Sheath, Quartz Tube or Quartz Lamp Elements
- 6" Wide Section (Type LN)
- 12" Wide Section (Type LW)

Applications

- Finish Curing
- Latex and Resin Curing
- Plastics Processing
- Ink Drying
- Textile and Non-Woven Fabric Manufacturing
- Paper and Paperboard Manufacturing
- Food Processing
- Ceramic Drying

Features

Wide Range of Heat Intensities in modular sections.

Two Widths — 6 inches (type LN) and 12 inches (type LW).

Four Lengths — 15, 21, 30 and 43 inches. LN, LW. — 44 inches LC-4 only.

Socket Assembly Terminal Block — Type LSO allows the mounting and wiring of metal sheath, quartz tubes or quartz lamp elements.



LN & LW — Dimensions (Inches)

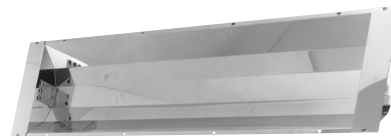
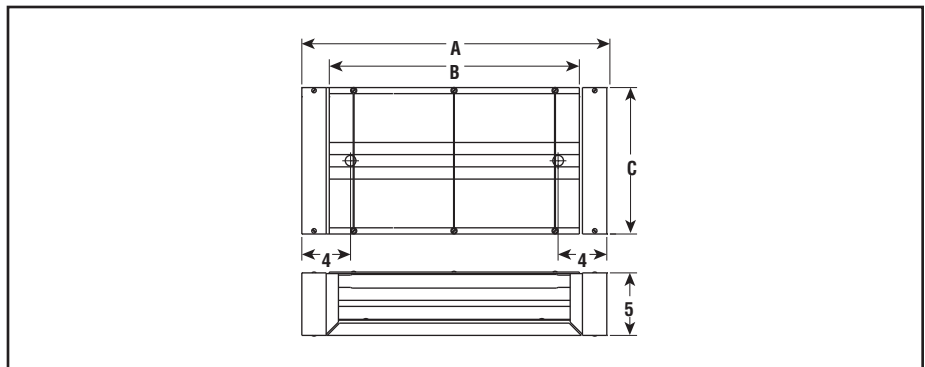

LC-4 — Dimensions (Inches)

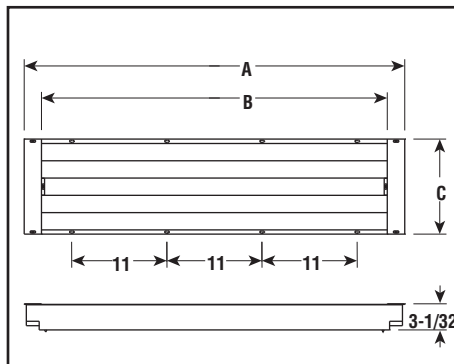

Construction

Heavy Duty Construction — 20 gauge cold rolled steel housing with double-back construction to accommodate both insulation and/or air cooling as desired.

Baked Green Enamel Finish — Reflective surfaces are bright aluminum.

Mounting — (4) 9/32" diameter knockouts are located on the back of each section that can be used for mounting with 1/4-20 bolts, nuts and lock washers. See Mounting Methods at the beginning of this Radiant section.

LC-4 — Asymmetrical Dim. (In)

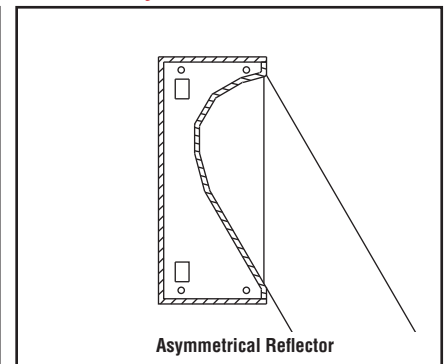

Optional Reflectors

Asymmetrical Reflector — This specially designed aluminum reflector, installed in one or more rows at top or bottom of heater banks, heats top and bottom surfaces of wide products, yet permits use of flat reflector banks without the complexity of angled-in reflectors. Available in LW width only. Chromalox can supply other sizes and ratings. Contact your Local Chromalox Sales office for price and availability. Order by part number 234-106117-024.

Lamp Conversion Reflectors — The LC-4 lamp conversion reflector permits tripling the heating capacity of the 11 x 44" reflector it replaces. The old reflector, installed in many plants, uses four G-30 lamps.

Process Air and Radiant

LN & LW

Infrared Oven Section Heater

Assemblies (*cont'd.*)

LN Heaters — Specifications and Ordering Information

Dimensions (In.)			Oven Section			Elements				
A	B	C	Model	Stock	PCN	kW	Volts	Model	Stock	PCN
Metal Sheath Elements										
15	11	6	LN-15AL	NS	120758	0.45	120	LMS-15	NS	114083
21	17	6	LN-21AL	NS	120766	0.725	208	LMS-21X1	NS	114104
21	17	6	LN-21AL	NS	120766	0.725	240	LMS-21	NS	114091
30	26	6	LN-30AL	NS	120774	1.15	208	LMS-30X1	NS	114120
30	26	6	LN-30AL	NS	120774	1.15	240	LMS-30	NS	114112
43	39	6	LN-43AL	NS	120782	1.75	208	LMS-43X1	NS	114147
43	39	6	LN-43AL	NS	120782	1.75	240	LMS-43	NS	114139
43	39	6	LN-43AL	NS	120782	1.75	480	LMS-43X2	NS	114155
Quartz Tube Elements										
15	11	6	LN-15AL	NS	120758	0.35	120	1-47624	NS	114235
21	17	6	LN-21AL	NS	120766	0.55	240	4-47624	NS	114243
30	26	6	LN-30AL	NS	120774	0.85	240	7-47624	NS	114251
43	39	6	LN-43AL	NS	120782	1.3	240	10-47624	NS	114260
Quartz Lamp (T-3) Elements										
15	11	6	LN-15AL	NS	120758	1	240	1000T-3	NS	114286
21	17	6	LN-21AL	NS	120766	1.6	240	1600T-3	NS	114307
30	26	6	LN-30AL	NS	120774	2.5	480	2500T-3	NS	114315
43	39	6	LN-43AL	NS	120782	3.8	575	3800T-3 ¹	NS	114331

LW Heaters — Specifications and Ordering Information

Dimensions (In.)			Oven Section			Elements				
A	B	C	Model	Stock	PCN	kW	Volts	Model	Stock	PCN
Metal Sheath Elements										
15	11	12	LW-15AL	NS	120715	0.45	120	LMS-15	S	114083
21	17	12	LW-21AL	NS	120723	0.725	208	LMS-21X1	S	114104
21	17	12	LW-21AL	NS	120723	0.725	240	LMS-21	S	114091
30	26	12	LW-30AL	NS	120731	1.15	208	LMS-30X1	NS	114120
30	26	12	LW-30AL	NS	120731	1.15	240	LMS-30	S	114112
43	39	12	LW-43AL	NS	120740	1.75	208	LMS-43X1	S	114147
43	39	12	LW-43AL	NS	120740	1.75	240	LMS-43	S	114139
43	39	12	LW-43AL	NS	120740	1.75	480	LMS-43X2	S	114155
Quartz Tube Elements										
15	11	12	LW-15AL	NS	120715	0.35	120	1-47624	AS	114235
21	17	12	LW-21AL	NS	120723	0.55	240	4-47624	AS	114243
30	26	12	LW-30AL	NS	120731	0.85	240	7-47624	NS	114251
43	39	12	LW-43AL	NS	120740	1.3	240	10-47624	AS	114260
Quartz Lamp (T-3) Elements										
15	11	12	LW-15AL	NS	120715	1	240	1000T-3	AS	114286
21	17	12	LW-21AL	NS	120723	1.6	240	1600T-3	AS	114307
30	26	12	LW-30AL	NS	120731	2.5	480	2500T-3	AS	114315
43	39	12	LW-43AL	NS	120740	3.8	575	3800T-3 ¹	AS	114331

LC-4 Reflectors — Specifications and Ordering Information

Dimensions (In.)			Oven Section			Elements				
A	B	C	Model	Stock	PCN	kW	Volts	Model	Stock	PCN
For LN or LW Heater Sections with Metal Sheath Elements										
44	39	11	LC-4	NS	114500	1.75	208	LMS-43X1	NS	114147
44	39	11	LC-4	NS	114500	1.75	240	LMS-43	S	114139
44	39	11	LC-4	NS	114500	1.75	480	LMS-43X2	S	114155
For LN or LW Heater Sections with Quartz Tube Elements										
44	39	11	LC-4	NS	114500	1.3	240	10-47624	AS	114260
For LN or LW Heater Sections with Quartz Lamp (T-3) Elements										
44	39	11	LC-4	NS	114500	3.8	575	3800T-3 ¹	AS	114331

Stock Status: S = stock AS = assembly stock NS = non-stock
To Order—Specify model and PCN of section and/or elements.

1. When used on 3kW, 480V or 1kW, 240V models.
2. Max. no. elements per section - Metal Sheath or Quartz Tube — 3, Quartz Lamp — 1 in LN, 2 in LW and LC-4.