

## GHTF

### Side Mount Heat Exchangers Fluoropolymer Heating or Cooling Coils

- Fluoropolymer Tube - 1/4" and 1/2" OD
- Surface Area (2-1/4 - 46-1/2 Ft<sup>2</sup>)

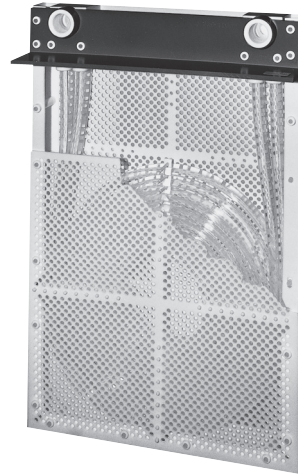

OVER-THE-SIDE

#### Features

- Polypropylene Guard, standard
- Standard Coils Rated to 30 psi Steam Service. Coils Available up to 60 psi
- 10 psi Minimum Steam Pressure Required for Operation
- Integral Inlet and Outlet Manifolds for Single Point Connections
- Options Available:
  - Anti-Floatation Brackets
  - Special Sizes and Manifold Configurations
  - L Shaped Configurations
  - Dual Coils for both Heating and Cooling

**Note:** Vacuum breakers recommended for fluoropolymer heat exchanger steam heating installations. Consult factory regarding reduced pressure applications.

#### Dimensions (Inches)

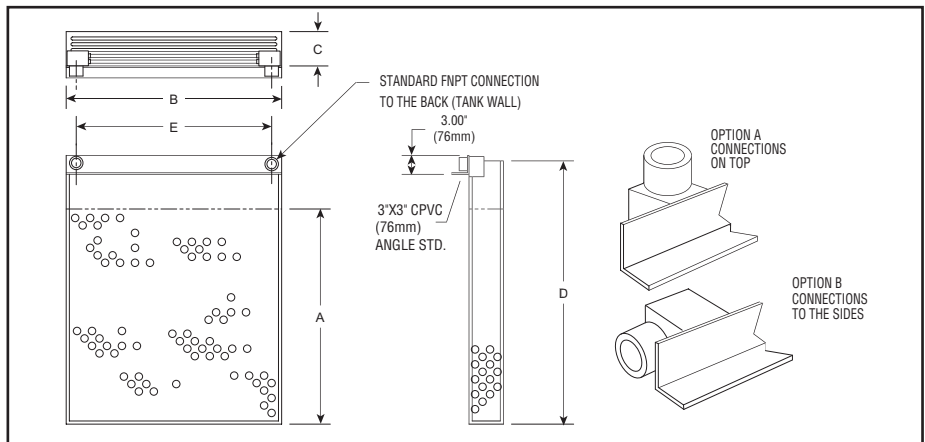

#### Specifications and Ordering Information

Surface Area (Ft <sup>2</sup> )	Dimensions (In.)					Fluoropolymer			Wt. (Lbs.)
	A	B	C	D	E	Model	Stock	PCN	
2-1/4*	11-1/2	11-1/2	1-1/2	17-1/2	9	GHTF-118	NS	362010	10
4-1/2*	11-1/2	11-1/2	2	17-1/2	8	GHTF-218	NS	362028	12
4-1/2*	15-1/2	15-1/2	1-1/2	21-1/2	12	GHTF-222	NS	362036	15
9-1/4*	15-1/2	15-1/2	2	21-1/2	12	GHTF-422	NS	362044	18
6	17-1/2	17-1/2	2	23-1/2	12-1/2	GHTF-224	NS	362052	22
12	17-1/2	17-1/2	3-1/2	23-1/2	12-1/2	GHTF-424	NS	362060	30
18	17-1/2	17-1/2	4-1/2	23-1/2	12-1/2	GHTF-624	NS	362079	38
24	17-1/2	17-1/2	5-3/4	23-1/2	12-1/2	GHTF-824	NS	362087	42
11-1/2	23-1/2	23-1/2	2	29-1/2	18-1/2	GHTF-230	NS	362095	32
23	23-1/2	23-1/2	3-1/4	29-1/2	18-1/2	GHTF-430	NS	362108	37
34-1/2	23-1/2	23-1/2	4-1/2	29-1/2	18-1/2	GHTF-630	NS	362116	41
46-1/2	23-1/2	23-1/2	5-3/4	29-1/2	18-1/2	GHTF-830	NS	362124	60

**Stock Status:** S = stock NS = non-stock  
**To Order**— Specify model, PCN and quantity.

\* Designates 1/4" diameter tubing. All others 1/2" diameter tubing

**Notes** —

- A. Heat transfer coefficient steam = 35 BTUH/FT<sup>2</sup>/°F.
- B. Heat transfer coefficient liquid = 30BTUH/FT<sup>2</sup>/°F.