

## System Options Expansion Tanks

### Dimensions (Inches)

#### CWG

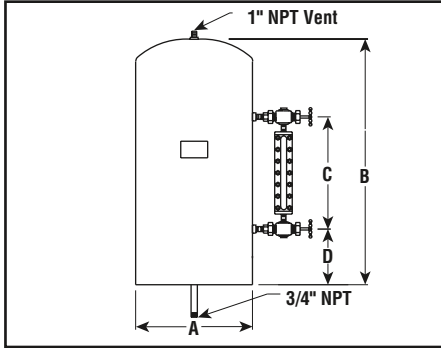

#### COS/PFC

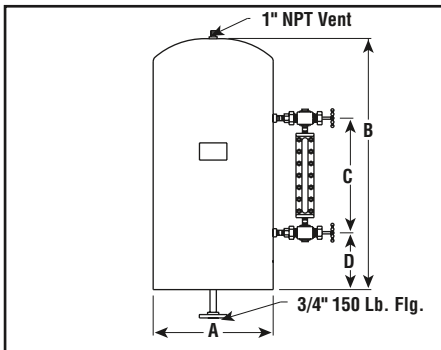

#### CLS

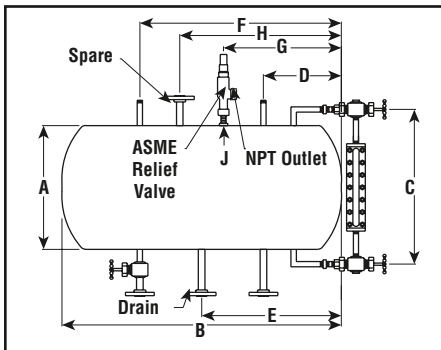

### Applications

An expansion tank is an essential component to all heat transfer systems. Heat transfer fluids expand with an increase in temperature. Expansion tanks allow for and contain the increase in volume due to temperature. In addition, cold expansion tanks provide a “seal” on the system reducing oxidation of the fluid. They also add to the net positive suction head (NPSH) on the inlet to the pump.

### Sizing

Expansion tanks should be sized based on the amount of thermal expansion of the heat transfer fluid in the system. The actual size of the tank should be at least double the anticipated increase in fluid volume. Tank capacity should be increased if the process piping is extensive and contains a significant volume of fluid. The following tables indicate the typical tank sizes for most systems.

**Steel Tanks Non-ASME rated 75 psig for MWS, CWG, MOS, COS and PFC Heat Transfer Systems — includes sight glass, 1" NPT vent and 3/4" NPT or 150 Lb. flanged system connection.**

Tank Capacity (Gal.)	Dimensions (In.)				CWG			COS/PFC			Wt. Empty (Lbs.)
	A	B	C	D	kW	PCN	Stock	kW	PCN	Stock	
12	12	25-1/2	14	5-3/4	6-18	—	NS	9-12	099944	NS	32
18	12	37-1/2	20	8-3/4	24-30	—	NS	15-30	099952	NS	44
30	16	38-1/4	20	9-1/8	40-100	—	NS	40	099960	NS	65
42	20	35	20	7-1/2	125-200	—	NS	60-80	099979	NS	80
80	20	63	38	12-1/2	250-400	—	NS	100-200	099987	NS	120
115	24	63-3/8	38	12-1/2	—	—	NS	250-400	099995	NS	145
215	30	73-3/8	38	17-1/8	—	—	NS	450-600	—	NS	210

**Stock Status:** S = stock NS = non-stock

**To Order**—Specify tank capacity, system type, kW, PCN and quantity.

**Steel Tanks ASME rated 200 psig @ 650°F for CLS Heat Transfer Systems — includes ASME relief valve, reflex type sight glass and two 1" 300 Lb. flanged system connections. Two 1/4" NPT fittings are provided for nitrogen (N<sub>2</sub>) purge connections.**

Tank Capacity (Gal.)	Dimensions (In.)										CLS			Wt. Empty (Lbs.)
	A	B	C	D	E	F	G	H	J	kW	PCN	Stock		
12	12	28	20	12	16	20	15	18	1	9	—	NS	50	
18	12	40	20	12	20	32	18	26	1	12-20	—	NS	60	
30	14	47	22	12	24	39	20	32	1	30	—	NS	70	
42	16	51	24	13	25	42	20	34	1	40	—	NS	105	
80	20	63	28	14	31	50	22	40	1	60-80	—	NS	205	
120	24	66	32	16	33	52	22	40	1	100-200	—	NS	310	
160	24	86	32	16	43	72	28	58	1-1/4	250-300	—	NS	350	
215	30	77	38	18	38	63	28	42	1-1/4	350-400	—	NS	405	
250	30	88	38	18	44	74	28	58	1-1/2	500-600	—	NS	540	

**Stock Status:** S = stock NS = non-stock

**To Order**—Specify tank capacity, system type, kW, PCN and quantity.

## System Options Cooling Modules Float & Level Switches

### Cooling Applications

Many processes require cooling as well as heating. Chromalox electric heat transfer systems can be designed with a cooling cycle using the same heat transfer fluid. This is accomplished by adding a water-cooled, air-cooled or refrigerated heat exchanger in the piping loop. By using mechanical refrigeration, systems can be designed to operate between -20 and 750°F (-28 and 398°C). Heat exchangers can be factory installed in MWS, CWG, MOS, COS, PFC, CLD and CLS systems.

**Stock Cooling Modules** — On new or existing MOS, COS, PFC or PFV systems, Chromalox can supply an RJC type cooling module. RJC modules are oil-to-water heat exchangers providing rapid cool down of heat transfer fluid. RJC modules are designed as an “add on” to be installed in line with the system piping. The module can be bolted to the existing framework of the system and quickly connected in line with the discharge piping of the unit. Modules can be connected in series for additional cooling capacity.

**Liquid Level Controls** — A liquid level control or float switch can be mounted on an expansion tank to automatically shut down the heat transfer system in case of low fluid levels. Two different switches are available for non-pressurized systems (MWS, CWG, COS and PFC) and for pressurized systems (CLD and CLS).

They are available with NEMA IV weather resistant and NEMA VII explosion proof enclosures. The non-pressurized switch can be used with most heat transfer fluids having a minimum specific gravity of 0.85. The control designed for pressurized applications will work with all heat transfer fluids having a minimum specific gravity of 0.70.

**Controls and Other Options** — Specialized electronic and hydraulic control schemes are available using the latest proportional and digital control equipment. Contact your Local Chromalox Sales office for details on the many heat transfer equipment options and accessories.

### Dimensions (Inches)

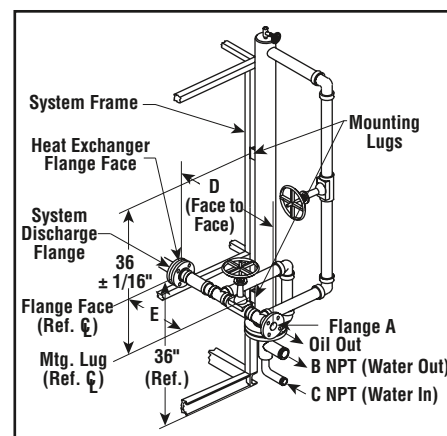
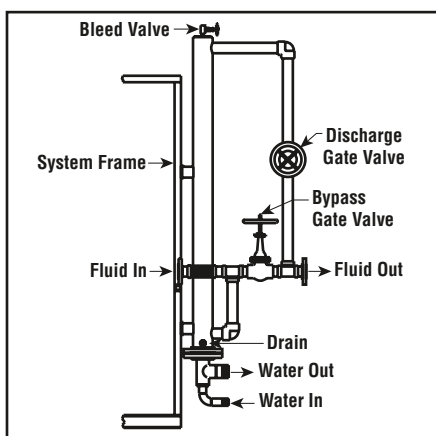

### Specifications and Ordering Information

Cooling Capacity Surface Area (Ft <sup>2</sup> )	Piping Connections and Dimensions (In.)					Estimated Sizing kW	Model	Stock	PCN	Wt. (Lbs.)
	1-1/2" Flg. (150 Lbs.) A	B	C	D	E					
10.8	1-1/2	1-1/2	1	29-1/2	14-1/8	9-30	RJC-12M1.5	NS	106964	294
10.8	2	1-1/2	1	29-1/2	14-1/8	40-80	RJC-12M2	NS	106972	310
19.78	2	2-1/2	1-1/4	29-1/2	13-1/8	40-80	RJC-20M2	NS	106980	390
25.35	2	2-1/2	1-1/4	29-1/2	13-1/8	40-80	RJC-25M2	NS	106999	442
25.35	3	2-1/2	1-1/4	29-1/2	13-1/8	100-400	RJC-25M3	NS	—	456

**Stock Status:** S = stock NS = non-stock  
**To Order** — Specify model, system type, kW, PCN and quantity.

### Liquid Level Control

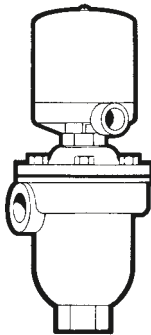

**Note** — For Non-Pressurized CWG, COS and PFC Systems and for Pressurized CLD and CLS Systems

**To Order** — Specify system model, electrical enclosure and expansion tank size.