

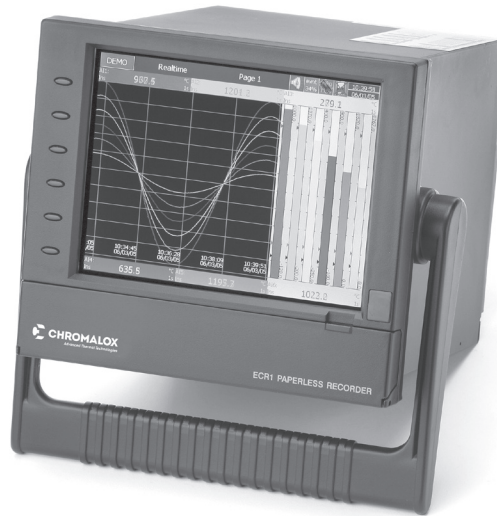

## ECR1 Electronic Chart Recorder

- 6.1" (155mm) Color TFT LCD Screen
- 640x480 Pixel (VGA) Resolution
- 1-18 Channel Universal Input Capability
- Plug and Play Input/Output Cards
- Easy-To-Access Function Keys
- Digital Ethernet Communications
- Optional RS-232\485\422 Interface
- Compact Flash Card Data Storage
- Alarm / Message Capability
- Infrared Motion Detector
- Various Display Formats
- Flexible Screen Configuration
- Timer, Counter and Totalizer Functions
- Bench-top or Panel Mount
- 120V Cord and Plug
- CE Agency Approvals



### Description

The ECR1 is the most advanced Paperless Recorder of its size with a pioneered set of features and true VGA (640x480) resolution. Its 18 channel Plug and Play architecture combined with a flexible screen set-up make for a user-friendly and versatile recorder. Each input channel can be set up in the field to accept 1 of 11 T/C or RTD choices, or 1 of 6 process sensors. The methods of displaying data vary from charts to bar graphs that can be displayed horizontally or vertically. As opposed to using a typical 1.4 MB 3.5" diskette for storage, the digital recorder ships with a 16 MB Compact Flash (CF) card for data storage. An Infrared Motion Detector will shutdown and automatically re-energize the display, both preserving the LCD screen and conserving power.

Included with the recorder is the Observer II software package for configuring the ECR1 and analyzing historical data via the CF card. Also

available, is the Observer II computer software package. The Observer II package allows for real time system monitoring and configuration through a PC via Ethernet or RS-232/485/422 communications.

Alarms or other events can be set to signal visually, audibly or through a set of outputs. Each digital output card consists of 6 independently programmable 3 Amp relays. A digital input card also allows the user to program one of 17 functions such as recording alarms, enabling timers or setting outputs. The Counter/Totalizer option allows the user to further report production results. The ECR1 also offers a panel mount depth of a very shallow 6.9" or the portable bench-top option, which includes a handle. With so many options, the ECR1 can be used to monitor, record or evaluate a wide array of applications in various industries.

### Panel Mounted Style

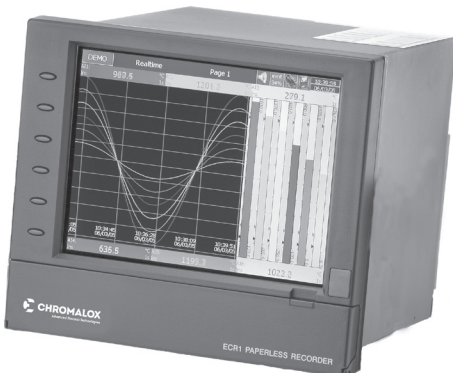

### Bench Top/Portable Style

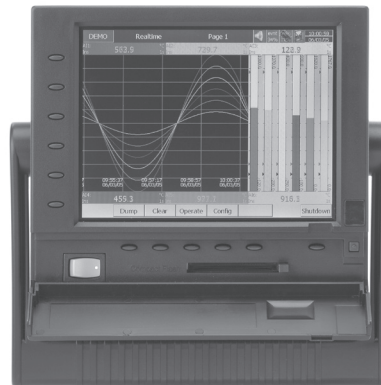

### 6 Slots for Plug & Play I/O Cards

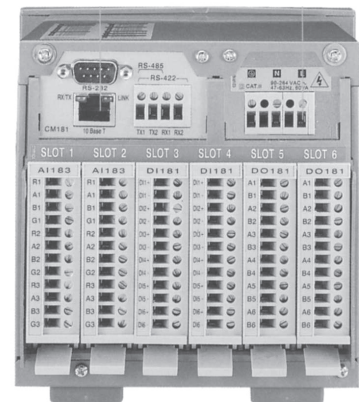

## ECR1 Electronic Chart Recorder *(cont'd.)*

### Specifications

<b>Power</b>	90-264 VAC, 47-63Hz, 60VA, 30W maximum 11-18 or 18-36 VDC 60VA, 30W maximum
<b>Display</b>	6.1" TFT LCD, 640x480 pixel resolution, 256 colors
<b>Memory</b>	
<b>Storage Memory on Board:</b>	8MB
<b>CF Card:</b>	16MB standard, Optional 500MB, 1 GB
<b>Analog Input Card</b>	(AI181, AI182, AI183)
<b>Resolution</b>	18 bits
<b>Sampling Rate</b>	5 times/second
<b>Maximum Rating</b>	-2 VDC minimum, 12 VDC maximum (1 min. for mA input)
<b>Temperature Effect</b>	±1.5 µV/°C for all inputs except mA input, ±3.0 µV/°C for mA input
<b>Sensor Lead Resistance Effect</b>	
<b>T/C:</b>	0.2 µV/ohm
<b>3-Wire RTD:</b>	2.6°C/ohm of resistance difference of two leads
<b>2-wire RTD:</b>	2.6°C/ohm of resistance sum of two leads
<b>Burn-Out Current</b>	200 nA
<b>Common Mode Rejection Ratio (CMRR)</b>	120dB
<b>Normal Mode Rejection Ratio (NMRR)</b>	55dB
<b>Isolation Breakdown Voltage Among Channels</b>	430 VAC min.
<b>Sensor Break Detection</b>	Sensor open for TC, RTD and mV inputs, below 1 mA for 4-20mA input, below 0.25V for 1-5V inputs, unavailable for other inputs.
<b>Sensor Break Responding Time</b>	Within 10 seconds for TC, RTD, and mV inputs, 0.1 second for 4-20 mA and 1-5V inputs.

### Digital Input Card (DI181)

<b>Channels:</b>	6 per card
<b>Logic Low:</b>	-30V minimum, 0.8V max.
<b>Logic High:</b>	2V minimum, 30V max.
<b>External Pull-Down Resistance:</b>	1KΩ maximum
<b>External Pull-Up Resistance:</b>	1.5MΩ maximum

### Digital Output Card (DO181)

<b>Channels:</b>	6 per card
<b>Contact Form:</b>	N.O. (form A)
<b>Relay Rating:</b>	5A/240 VAC, life cycles 200,000 for resist. load

### COMM Module (CM181)

<b>Interface:</b>	RS-232 (1 unit), RS-485 or RS-422 (up to 247 units)
<b>Protocol:</b>	Modbus Protocol RTU mode
<b>Address:</b>	1-247
<b>Baud Rate:</b>	0.3-38.4 Kbits/sec.
<b>Data Bits:</b>	7 or 8 bits
<b>Parity Bit:</b>	None, Even or Odd
<b>Stop Bit:</b>	1 or 2 bits

### Standard Ethernet Communication

<b>Protocol:</b>	Mod Bus TCP/IP, 10 BaseT auto polarity correction for 10 BaseT
<b>Ports:</b>	AUI (Attachment Unit Interface) and RJ-45 Auto- detect capability

### Infrared Detector

<b>Distance</b>	Detect moving human body within 2 meters
-----------------	--

### Environmental & Physical

<b>Operating Temp.:</b>	5°C to 50°C
<b>Storage Temp.:</b>	-25°C to 60°C
<b>Humidity:</b>	20 to 80% RH (non-condensing)
<b>Insulation Resistance:</b>	20 Mohms min. (at 500 VDC)
<b>Dielectric Strength:</b>	3,000 VAC 50/60 Hz for 1 minute
<b>Vibration Resistance:</b>	10-55 Hz, 10m/S <sup>2</sup> for 2 hours
<b>Shock Resistance:</b>	30m/S <sup>2</sup> (3g) for operation, 100g for transportation

### Approval Standards

<b>Safety:</b>	UL873 (11th edition, 1994) CUL CE: EN61010-1 (IEC1010-1) Overvoltage category II, Pollution degree 2
<b>Protective Class:</b>	IP 30 front panel, indoor use, IP 20 housing and terminals

### EMC

<b>Emission:</b>	EN50081-1, EN61326 (EN55011 class B, EN61000-3-2, EN61000-3-3)
<b>Immunity:</b>	EN50082-2, EN61326 (EN61000-4-2, EN61000-4-3, EN61000-4-4, EN61000-4-5, EN61000-4-6, EN61000 4-11, EN50204)

### Panel Cutout

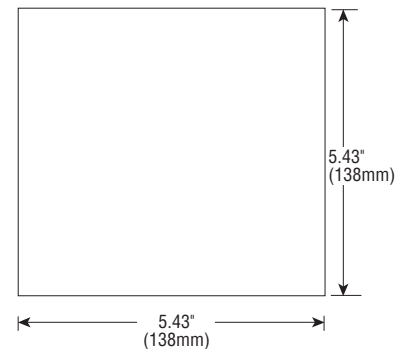

### Dimensions

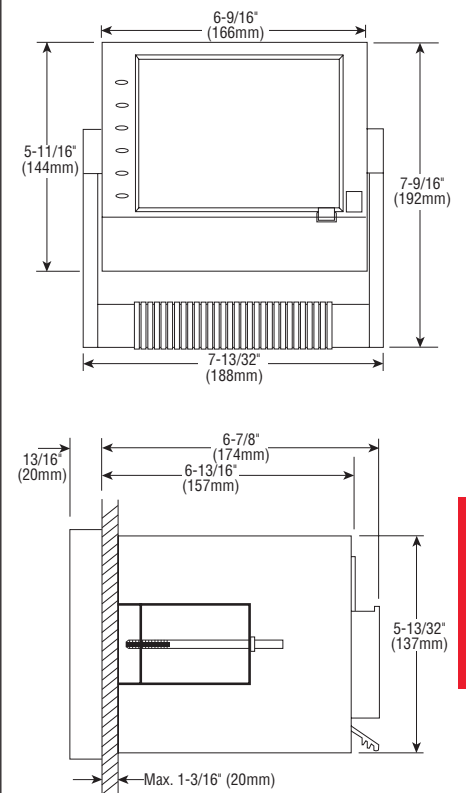

All Dimensions in In. (mm)

## ECR1 Electronic Chart Recorder *(cont'd.)*

### Accessories

Part Number	Description
AI183	3-channel analog input card (TC, RTD, +mA, +V, +mV)
DI181	6-channel digital input card
DO181	6-chan. relay output card (AC/DC)

### Ordering Information

*To Order — Complete the Model Number using the Matrix provided.*

Model **ECR1 Electronic Chart Recorder Basic Configuration**  
ECR1

Code	Power
4	90-250 VAC, 47-63 Hz
6	11-18 VDC
7	18-36 VDC
Code	Analog Input Card
3	3 Channels (1 Card*)
6	6 Channels (2 Cards*)
A	9 Channels (3 Cards*)
B	12 Channels (4 Cards*)
C	15 Channels (5 Cards*)
D	18 Channels (6 Cards*)
Code	Digital Input Card
0	None
1	6 Channels (1 Card*)
2	12 Channels (2 Cards*)
Code	Digital Output Card
0	None
1	6 Relays (1 Card*)
2	12 Relays (2 Cards*)
Code	Communications
0	Standard Ethernet Interface
1	RS-232/422/485 (three in one)* Ethernet interface
Code	PC Software
1	Free Basic Observer I for non-communication appl.
2	Extensive Observer II for communication via RS-232/422/485 or Ethernet
Code	Firmware
0	Basic Function
1	w/Mathematics, Counter & Totalizer Functions
Code	Storage Media
1	500MB Compact Flash Card (CF)
4	1GB Compact Flash Card (CF)
Code	Case/Mounting
1	Standard Panel Mount
2	Bench Top / Portable Style with Handle
Code	Special Option
0	None
1	24 VDC Aux. Pwr. Suppl. (Transmitter, 6 Channels)

ECR1 4 A 0 0 0 1 0 1 1 0 Typical Model Number

\* Standard model without options, ECR1-4A00010110.

\* The rear slots of the recorder will only accept up to 6 cards in any combination.

### Universal Sensor Inputs

**Thermocouples:** J, K, T, E, B, R, S, N, L

**RTD:** PT100 DIN, PT100 JIS

**Process:** 0 - 20 mA, 4 - 20 mA,  
0 - 5 V, 1 - 5 V, 0 - 10 V,  
0 - 60 mV, 0 - 1000 mV