



## CHSI Electric Steam Boiler

- 735 - 4,550 Lbs/Hr
- 210-1,300 kW
- 480 or 600 Volt, 3 Phase (208, 240 available on 210 and 270kW units)
- ASME Section I, "S" Stamp
- Incoloy Sheath Heating Elements
- Proportional Control
- 100kA SCCR Rating (with appropriate fused disconnects)
- Modbus, BACnet available
- Touchscreen Control



### Features

**Trimmed at 150 psig** — for operation up to 135 psig corresponding to 353°F. Alternate trims available.

**Integral Electrical Controls and Power Panel** mounted in heavy gauge control cabinet with hinged doors

**Intuitive Touchscreen** — A 5.7" Color Touchscreen with dedicated BMS Modbus.

**Standard I/O** — Dedicated outputs for element staging. Individual input for monitoring for safety devices with alarm communication.

**Ease of Replacement** — Horizontal element bundles allow easy removal and replacement to avoid long down times.

**Incoloy Elements** — Robust Incoloy 800 heating element bundles for longer life.

**Thick-walled Pressure Vessel** — Exceeds ASME minimum requirements.

**Insulation material** — around the entire pressure vessel minimizes heat loss and helps reduce energy costs.

**Water Feed and Low Water Cutoff** — automatically maintains correct water level and shuts off the boiler when the water level in the boiler drops below safe limits.

**Auxiliary Low Water Cutoff** — Provides backup protection for low water level in the boiler.

**Water Level Sight Glass** — allows for constant visual observation of the water level in the boiler during operation.

**Steam Pressure Gauge** — with a range to 300 psig provided for visual indication of steam pressure.

**Zero Scope-1 Emissions** — Fully Electric steam generation.

### Optional

**BACnet** — Optional BACnet communication is available upon request.

**Optional Pressure Trims** — available with 200, 250 and 300 psig trim upon request. (Increases Lead Times)

**CRN Pressure Code** — CRN not currently available, registration can be pursued upon request.

### Description

CHSI Steam Boilers are designed to meet sustainability demands with industry-leading features as standard. A carefully calculated heat-to-water ratio achieves operating pressures quickly and with nearly 100% efficiency. By eliminating the use of fossil fuels and combustion processes, these boilers provide a clean and green alternative for a variety of industrial and commercial applications.

## CHSI Electric Steam Boiler

### Specifications and Ordering Information

Steam(lbs/hr)*	BHP	kW	Volts**	Phase	Amps	Dimensions (in)				Model	Weight(lbs)	
						Height (A)	Width (B)	Depth (C)	Clearance (D)		Shipping	Operating
735	21	210	480	3	254	76-7/8"	56-3/4"	43-3/4"	36"	CHSI-0210	1,500	2,125
735	21	210	600	3	203	76-7/8"	56-3/4"	43-3/4"	36"	CHSI-0210	1,500	2,125
945	28	270	480	3	326	76-7/8"	56-3/4"	43-3/4"	36"	CHSI-0270	1,500	2,125
945	28	270	600	3	261	76-7/8"	56-3/4"	43-3/4"	36"	CHSI-0270	1,500	2,125
1,400	41	400	480	3	483	83-3/4"	76-5/8"	65-3/4"	47"	CHSI-0400	4,300	6,800
1,400	41	400	600	3	386	83-3/4"	76-5/8"	65-3/4"	47"	CHSI-0400	4,300	6,800
1,750	51	500	480	3	603	83-3/4"	76-5/8"	65-3/4"	47"	CHSI-0500	4,300	6,800
1,750	51	500	600	3	482	83-3/4"	76-5/8"	65-3/4"	47"	CHSI-0500	4,300	6,800
2,100	61	600	480	3	723	97-1/2"	74-1/2"	65-5/8"	46"	CHSI-0600	4,500	7,640
2,100	61	600	600	3	579	97-1/2"	74-1/2"	65-5/8"	46"	CHSI-0600	4,500	7,640
2,450	71	700	480	3	844	97-1/2"	74-1/2"	65-5/8"	46"	CHSI-0700	4,500	7,640
2,450	71	700	600	3	675	97-1/2"	74-1/2"	65-5/8"	46"	CHSI-0700	4,500	7,640
2,800	82	800	480	3	964	97-1/2"	74-1/2"	65-5/8"	46"	CHSI-0800	4,500	7,640
2,800	82	800	600	3	771	97-1/2"	74-1/2"	65-5/8"	46"	CHSI-0800	4,500	7,640
3,500	102	1,000	480	3	1,204	97-3/4"	91-3/4"	84-1/2"	42-3/8"	CHSI-1000	8,580	13,500
3,500	102	1,000	600	3	964	97-3/4"	91-3/4"	84-1/2"	42-3/8"	CHSI-1000	8,580	13,500
4,550	133	1,300	480	3	1,565	97-3/4"	91-3/4"	84-1/2"	42-3/8"	CHSI-1300	11,790	13,500
4,550	133	1,300	600	3	1,252	97-3/4"	91-3/4"	84-1/2"	42-3/8"	CHSI-1300	11,790	13,500

\*Steaming capacity is based on producing saturated steam at 212 °F, Opsig.

\*\*120V 1PH 60Hz Control Voltage is standard

**NOTE:** Specifications and dimensions are approximate and for reference only. Chromalox practices continuous product improvement and reserves the right to change specifications and/or dimensions without notice.

### Dimensions

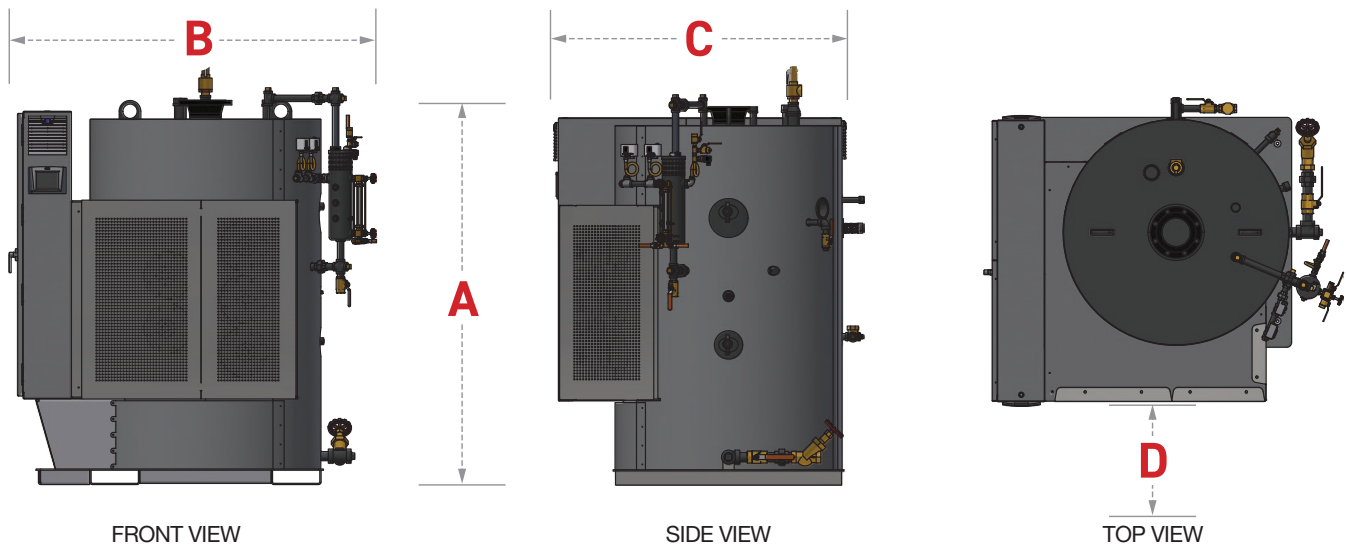

**"Under the U.S. Federal Safe Drinking Water Act, it is unlawful to install or use this product in any service that comes into contact with water for human consumption (including drinking, food or beverage preparation, hand washing, or teeth brushing). This product is intended exclusively for use in non-potable service."**