

## 7150 Pump House Convection Heater

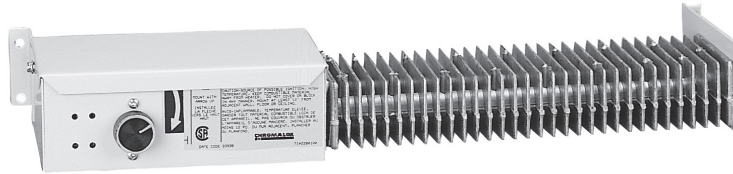

- 500 Watts
- 1,706 Btuh
- 120 and 240 Volt
- Single Phase

### Dimensions (Inches)

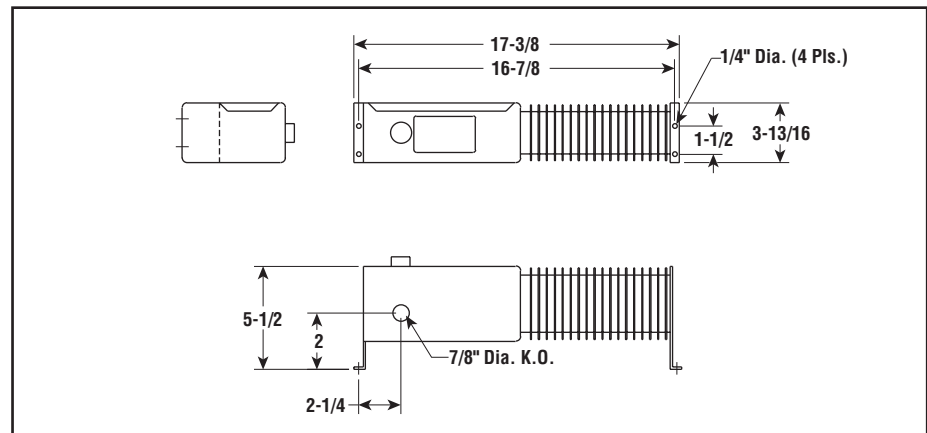

### Description

CPHH pump house heaters provide around the clock freeze protection or heat anywhere it's needed. The heater features a built-in thermostat and can be left unattended all winter long. The rugged cast grid heating element can withstand most any environment.

### Applications

- Boiler Rooms
- Water Pump Sheds (golf course)
- Garage Grease Pits
- Equipment Buildings
- Control Panels

### Construction

**Control Enclosure** — Heavy gauge formed steel corrosion treated and painted with a hybrid polyester epoxy coating.

**Heating Element** — Cast aluminum heating grid.

**Control** — Built-in bimetallic adjustable thermostat with 40 to 80°F range.

**CAUTION** — Not intended for use where flammable vapors, gases, liquids or other combustible atmospheres are present.

### Advantages

- Long Life
- Self Contained
- For Unattended Locations
- Corrosion Resistant

### Specifications and Ordering Information

Electrical					Dimensions (In.)			Ordering			Wt. (Lbs.)
Watts	Volts	No. Elem.	Amps	Btuh	Height	Width	Depth	Model	Stock	PCN	
500	120	1	4.2	1,707	2-1/2	18-7/8	6-1/8	7150B11	S	350190	5
500/375	240/208	1	2.1	1,707	2-1/2	18-7/8	6-1/8	7150B31	NS	350203	5

**Stock Status:** S = stock NS = non-stock  
**To Order**—Specify model, PCN, kW, volts, phase and quantity.