

6150/4150 Limit Controllers

- Universal Input
- Large LCD Display
- Easy and Guided Configuration with Power off
- ModBus Communications
- Up to 4 Outputs
- Retransmit Process Value or Limit Setpoint
- Modbus Comms (RS485)
- Security Options
- Available in 1/16 & 1/4 DIN Sizes
- Optional Configuration Software
- UL, cUL, CE
- 3 Year Warranty



Description

Whether you have to manage temperature, flow, valve positioning or pressure, the new Chromalox 50 Series Temperature & Process Controllers provide you with a comprehensive feature list and the flexibility to meet your most demanding process needs.

The optional C-PWR configuration software, which can be found on www.chromalox.com, allows the owner to program multiple units efficiently and store parameter settings for later use.

The 40 Series Controllers are an ideal complement in both design and esthetics to its cousin, the Chromalox 50 Series Limit Controllers.

Accessories	
Part Number	Description
0149-50200	Programming Cable
0149-50201	Gasket for 6150
0149-50202	Gasket for 4150
0149-50203	Fastening Clip for 6150
0149-50204	Fastening Clip for 4150

6150 (1/16 DIN) Standard Offering Order Table												
Power Supply Voltage	Model	Inputs			Outputs					Logic functions	Total Number of Outputs	
		Digital	CT	Remote Setpoint	Relay	Triac	SSR Driver	Analog I	Analog Retrains			RS485
20-27V	6150-R-RR0-00000-0-G				3							3 outputs
100-240V	6150-R-RR0-00000-1-G				3							3 outputs
20-27V	6150-R-RR0-01011-0-G	1			3			1	•			4 outputs
100-240V	6150-R-RR0-01011-1-G	1			3			1	•			4 outputs

4150 (1/4 DIN) Standard Offering Order Table												
Power Supply Voltage	Model	Inputs			Outputs					Logic functions	Total Number of Outputs	
		Digital	CT	Remote Setpoint	Relay	Triac	SSR Driver	Analog I	Analog Retrains			RS485
20-27V	4150-R-RR0-00000-0-G				3							3 outputs
100-240V	4150-R-RR0-00000-1-G				3							3 outputs
20-27V	4150-R-RR0-01051-0-G	5			3			1	•			4 outputs
100-240V	4150-R-RR0-01051-1-G	5			3			1	•			4 outputs

Bold Model Codes are Stocked

If a custom model is required please contact your local Chromalox representative, minimum of 5 pieces

6150/4150

Limit Controllers *(cont'd.)*

INPUTS		6150	4150
MAIN INPUT	Sensor type	TC, RTD (PT100, JPT100), infrared sensor (only for 4140), DC linear sensor	
	Accuracy	TC inputs: Calibration accuracy: < +/- (0,25% of reading value in °C +0,1°C) Linearization accuracy: 0,1% of reading value Cold junction accuracy: < +/- 1,5°C a 25°C room temperature) Cold junction compensation: > 30:1 rejection to the change of the room temperature RTD input: Calibration accuracy: < +/- (0,15% of reading value in °C +1°C) Temperature drift: < +/- (0,005% of reading value in °C +0,015°C)/°C from 25°C room temperature Linearization accuracy: 0,1% of reading value Linear inputs: Calibration accuracy:< 0,1% full scale Temperature drift: < +/- 0,005% full scale /°C at 25°C room temperature	
	Sampling time	60 ms / 120 ms, selectable	
	Digital filter	0,0...20,0 s	
	Temperature unit of measurement	Degrees C / F, selectable from keypad	
	Signal interval	Type: linear Scale: -1999...9999, settable decimal point	
	TC (thermocouple) input	Thermocouple: J, K, R, S, T, C, D, B, E, L, L-GOST, U, G, N, Pt20Rh-Pt40Rh Linearization: ITS90 or custom	
	RTD (resistance thermometer) input	Resistance thermometer: PT100, JPT100 Input impedance (Ri): ≥ 30 kΩ Linearization: DIN 43760 or custom Max. line resistance: 20 Ω	
	DC linear input	0...60 mV 0...1 V 0...5 V / 0...10 V 0/4...20 mA	input impedance (Ri): > 70 kΩ input impedance (Ri): > 15 kΩ input impedance (Ri): > 30 kΩ input impedance (Ri): 50 Ω
AUXILIARY INPUT	Remote setpoint	0...1 V, 0...10 V, 0/4...20 mA	
	Scale	0...1 V 0...10 V 0/4...20 mA	input impedance (Ri): > 15 kΩ input impedance (Ri): > 30 kΩ input impedance (Ri): 50 Ω
	Accuracy	0,1% f.s. ±1 digit @25 °C	
CT (ammeter) INPUT	Type	Isolated via external transformer Number: 2 max Max. capacity: x / 50 mA AC Line frequency: 50/60 Hz Input impedance (Ri): 10 Ω	
	Accuracy	±2% f.s. ±1 digit @25 °C	
DIGITAL INPUTS	Type	voltage-free contact, or NPN 24 V - 4,5 mA, or PNP 12/24 V - max 3,6 mA <i>(for detail see electrical connections)</i>	
	Isolation	500 V	
	Number	3 max	5 max

6150/4150

Limit Controllers *(cont'd.)*

OUTPUTS		6150	4150
	Relay (R)	Number: 4 max Type of relay contact: NO Max. current: 5 A, 250 VAC Minimum load: 5 V, 10 mA Life cycle: > 100.000 operations Double isolation	Number: 4 max Type of relay contact: NO Max. current: 5 A, 250 VAC / 30 VDC, $\cos\phi = 1$
	Logic (D)	Number: 2 max Type: for solid-state relays Voltage: 24 V $\pm 10\%$ (min 10 V @20 mA) Isolated from main input	
	Triac (long life relay) (T)	Number: 1 max Load: resistive Voltage: 75...264 VAC Current max: 1 A Isolation 3 kV snubber circuit integrated zero crossing switching	
	Continuous (C)	Number: 1 max Current: 4...20 mA $R_{out} < 500 \Omega$ Resolution: 12 bit Isolated from main input	
	Analog retransmission (A1)	Number: 1 max 0...10 V, max 20 mA, $R_{out} > 500 \Omega$ 0...20 mA, 4...20 mA, $R_{out} < 500 \Omega$ Resolution: 12 bit Isolated from main input	
ALARMS	Number of alarm functions	4 max, assignable to an output	
	Possible configurations	Maximum, minimum, symmetric, absolute/relative, exclusion at firing, memory, reset from keypad and/or contact, LBA, HB, HBB Hold Back Band if enabled with Programmer function	
CONTROL FUNCTIONS		6150	4150
CONTROL	Type	Single loop	
	Control	PID, ON/OFF, single action heat or cool, double action heat/cool	
	Control output	Continuous or ON/OFF Cycle time: constant or optimized (BF)	
	Control output for motorized valves	OPEN/CLOSE for floating motorized valve on Relay, Solid-state, Triac outputs	
SETPOINT PROGRAMMER	Number of programs	Max 4 Start / Stop / Reset / Skip via digital inputs and/or outputs from logic operations Output state: Run /Hold / Ready / End	
	Number of steps	Max 32 freely selectable if in non-simplified mode: if in "Simplified programmer" mode, MAX 8 steps per program, with fixed order: Program 1, Step 1-8, Program 2, Step 9 - -16, and so on. Each with own setpoint, ramp time and hold time Times settable in HH:MM or MM:SS Max 4 consents, configurable for ramp and for hold Max 4 events, configurable in ramp and in hold	
MULTIPLE SETPOINTS	Number of setpoints	Max 4, selectable from digital input Each setpoint change is subject to set ramp, different for up and down ramp	

6150/4150

Limit Controllers *(cont'd.)*

CONTROL FUNCTIONS		6150	4150
TIMER FUNCTION	Modes	START / STOP STABILIZATION (timer is on when PV enters a band set around setpoint; at end of count you can activate an output, shut down SW or change SP1/SP2) FIRING (timed activation of control after power on)	
	ENERGY COUNTER	Calculation done on nominal line voltage and nominal load power or on rms current measured on load via CT	
DIAGNOSTIC		Short circuit or open circuit (LBA alarm) Interrupted or partially interrupted load (HB alarm) Short circuit of control output (SSR alarm)	
RETENTIVE MEMORY	Type	EEPROM	
	Max. number of writes	1.000.000	
SERIAL INTERFACE		6150	4150
		Type: RS485 Baudrate: 1200, 2400, 4800, 9600, 19.200, 38.400, 57.600, 115.200 bit/s Protocoll: MODBUS RTU Isolated from main input	
GENERAL DATA		6150	4150
POWER SUPPLY	Operating voltage	100...240 VAC/VDC $\pm 10\%$, 50/60 Hz (on request 20...27 VAC/VDC $\pm 10\%$)	
	Power dissipation	5 W max	10 W max
	Protections	Overvoltage 300 V / 35 V	
	Connection	Screw terminals and crimp connector, max. wire section 1 mm ²	
CONNECTIONS	Serial configuration port (for USB connection)	Connector: microUSB	
	Inputs and outputs	Screw terminals and crimp connector, max. wire section 2,5 mm ²	
AMBIENT CONDITIONS	Use	Indoor	
	Altitude	2000 m max	
	Operating temperature	-10 ... +55 °C (as per IEC 68-2-14) (14 ... +131 °F)	
	Storage temperature	-20 ... +70 °C (as per IEC 68-2-14) (-4 ... +158 °F)	
PROTECTION LEVEL	Relative humidity	20...85% RH non-condensing (as per IEC 68-2-3)	
ASSEMBLY	Positioning	On panel, removable faceplate	
	Installation regulations	Installation category: II; Pollution degree: 2 Isolation: double	
DIMENSIONS		48 × 48 mm (1/16 DIN), Depth: 80 mm	96 × 96 mm (1/4 DIN) Depth: 80 mm
WEIGHT		0.16 kg / 0.353 lbs	0.24 kg / 0.53 lbs
CE STANDARDS	EMC (electromagnetic compatibility)	Conforms to directive 2014/30/EU with reference to standard EN 61326-1 emission in industrial environment class A for models 650 LV emission in residential environment class B for models 650 HV	
	Safety LVD	conforms to directive 2014/35/EU with reference to standard EN61010-1	

6150/4150

Limit Controllers *(cont'd.)*

6150 DIMENSIONS AND DRILLING TEMPLATE

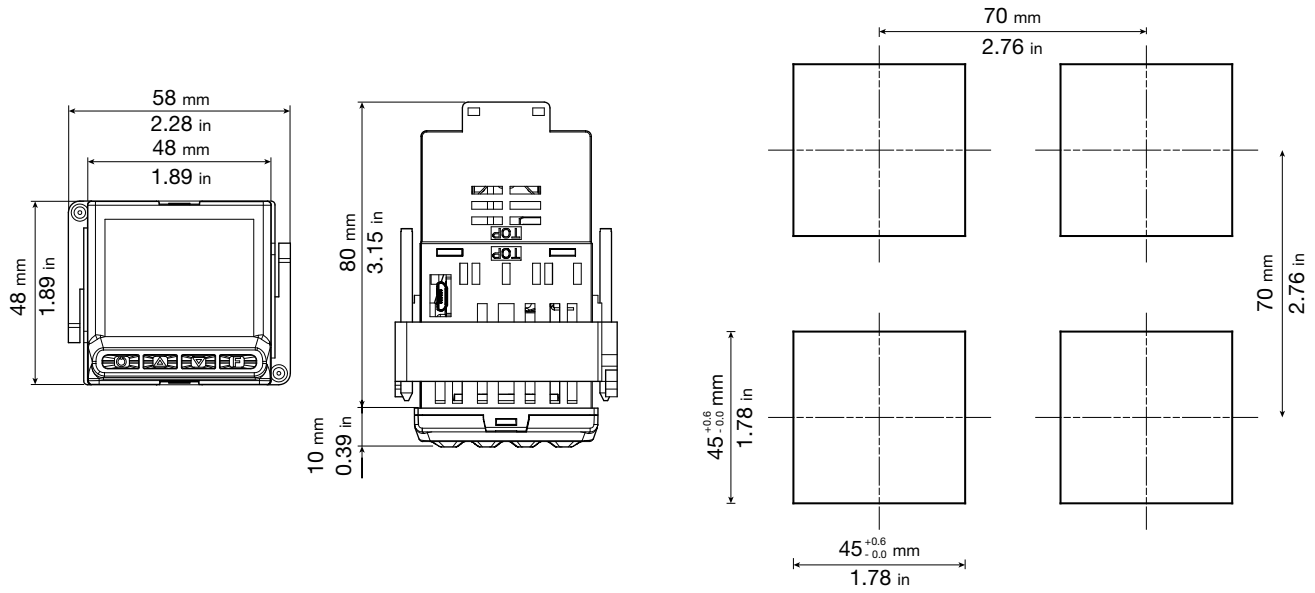

4150 DIMENSIONS AND DRILLING TEMPLATE

