

UMC Multiple Power Connection/Splice/Tee Kit

Self-Regulating & Constant Wattage Heating Cable Installation Instructions

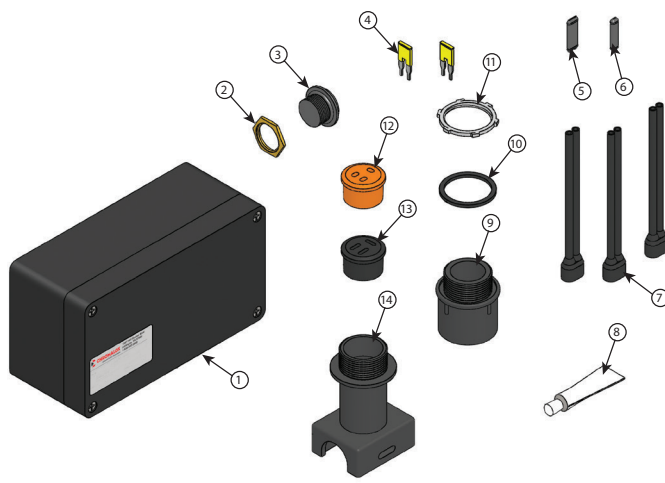

Item	Qty	Description
1	1	Junction Box
2	1	Brass Locknut (when used as Splice/Tee)
3	1	Conduit Plug (when used as Splice/Tee)
4	2	Jumper
5	1	Self-Regulating Grommet Insert
6	1	Constant Wattage Grommet Insert
7	3	Silicone Termination Boot
8	1	RTV
9	1	Compression Fitting
10	1	O-Ring
11	1	Locknut
12	1	Constant Wattage Grommet
13	1	Self-Regulating Grommet
14	1	Pipe Standoff

General

The UMC power connection/splice/ tee kit is used for electrical termination, splice, or tee of self-regulating and constant wattage cables. Each kit contains the terminations needed to make all electrical connections.



Ex CE 2903 IIG Ex eb IIC T* Gb Ta -60°C to 195°C
 IECEx ITS 07.0018X
 Ex e IIC T* Gb Ta -60°C to 195°C
 *For T -Ratings, see heating cable

Certifications & Approvals

Type 4X -40°C<Ta<+55°C
 Ordinary & Hazardous Locations
 Class I, Division 2 Groups A*,B,C&D
 Class II, Division 2 Groups E, F & G
 *CSA only

Tools Required for Kit Installation

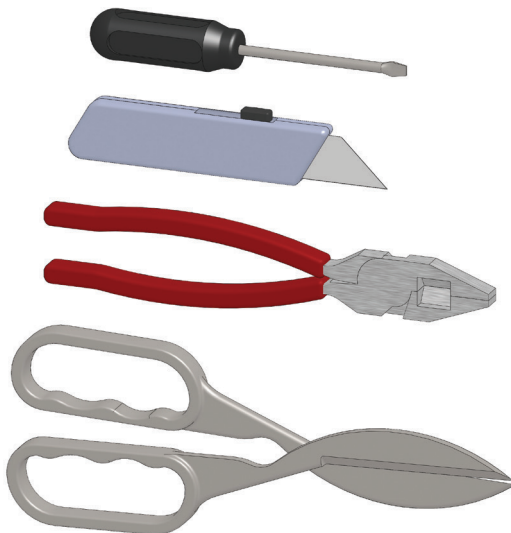

Actual Kit Dimensions

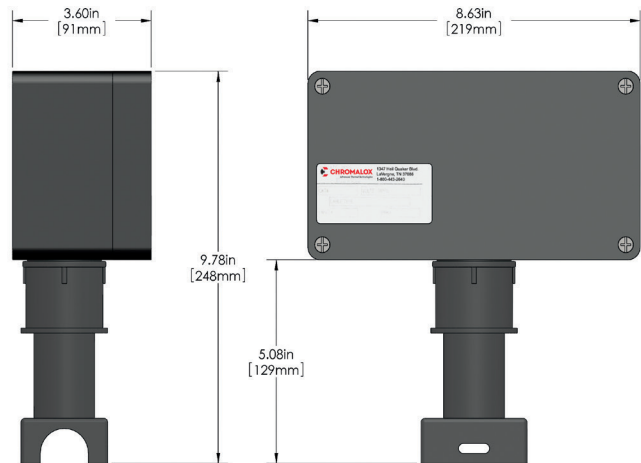

⚠ WARNING

HAZARD OF ELECTRIC SHOCK. Disconnect all power before opening. All installations must be effectively grounded in accordance with the National Electrical Code to eliminate shock hazard. To avoid electrostatic discharge, wipe with damp cloth.

⚠ WARNING

Turn off power before removing junction box cover at all times.

⚠ WARNING

Users should install adequate controls and safety devices with their electric heating equipment. Where the consequences of failure may be severe, back-up controls are essential. Although the safety of the installation is responsibility of the user, Chromalox will be glad to assist in making equipment recommendations.

Order Separately

Pipe Straps

- PS - 1 (382352) - 1/2" to 3/4" pipes
- PS - 3 (382360) - 1" to 3-1/2" pipes
- PS - 10 (382379) - 2-1/2" to 9" pipes



Caution Label CL-1 (382424)

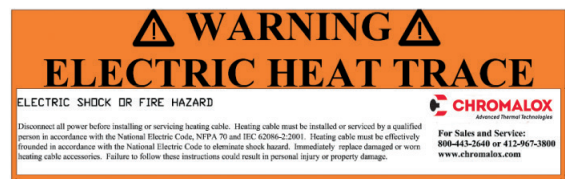

Fiberglass Tape FT-3 (389941)



Cable installation instructions: SRL, SRF, SRM/E, SRP, SRH600

Braid only and CWM cable special instructions denoted by *

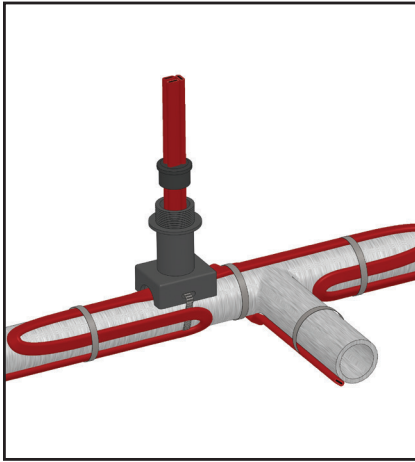

1. Insert heating cable through pipe standoff and grommet as shown. 8 inches of cable should extend past the grommet. If only two cables are entering the kit close off the remaining grommet opening with the appropriate grommet insert. Attach the pipe standoff to the pipe with a pipe strap (Chromalox type PS not included) as shown. Attach extra cable to pipe as appropriate. For pipes smaller than 1-1/2" diameter optional small pipe adapter (Chromalox model SPA not included) is required.

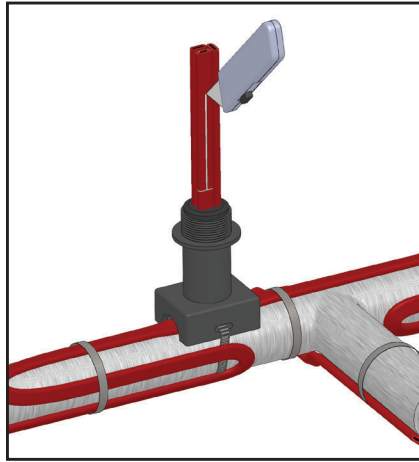

2. Score the outer insulation 7 inches from the end of the cable. Lightly cut the outer jacket up the center to the end of heating cable and remove the outer jacket from the cable. **WARNING: DO NOT CUT METAL BRAID.**

Note: If using braid only cable (-C), skip this step.

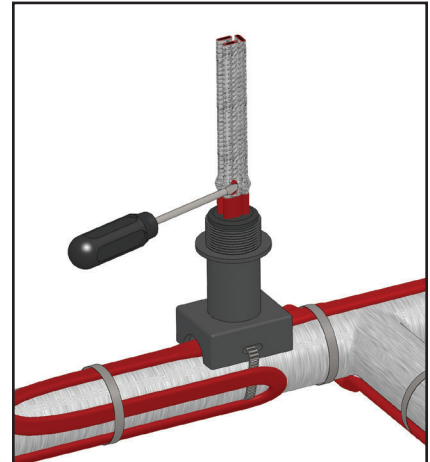

3. Move braid back toward the over-jacket, creating a bulge. At the bulge, separate the braid to make an opening.

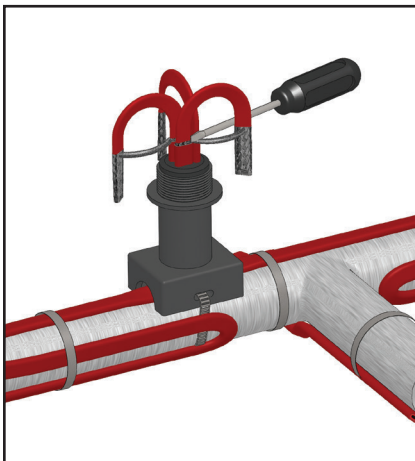

4. While bending the heating cable, work the cable through the braid opening. Pull the braid tight.

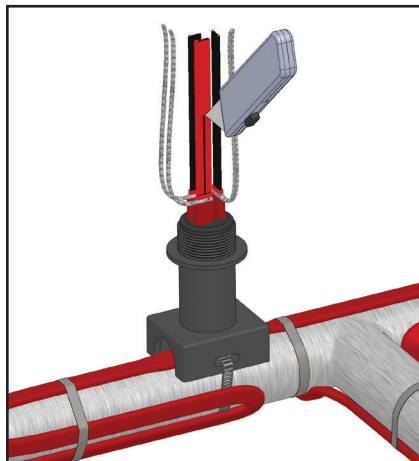

5. Score the inner insulation 6 inches from the end. Lightly cut the inner jacket up the center to end of heating cable and remove the inner jacket from the cable.

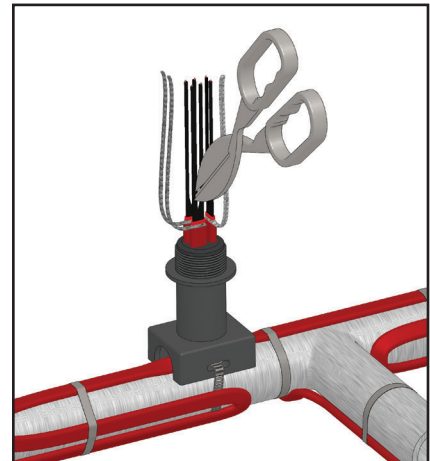

6. Use Tin Snips or similar tool to cut excess matrix material from between the two buss wires.

*Separate CWM leads

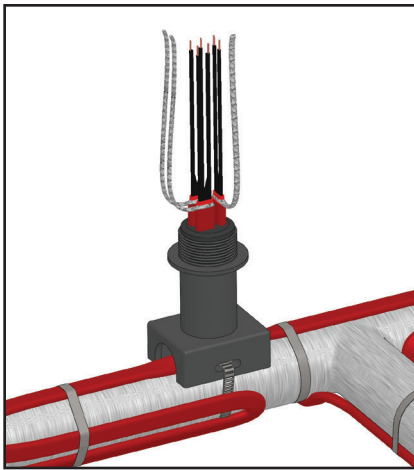

7. Strip each bus wire 1/4".
 *Separate CWM leads and strip 1/4" from each leadwire.

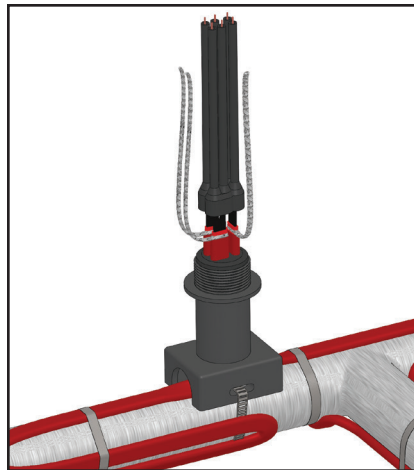

8. Liberally apply RTV over the exposed matrix and leads. Push the rubber boot over the heating cable. Trim lead ends as needed.
 *Boot is not needed when using CWM constant wattage cable.

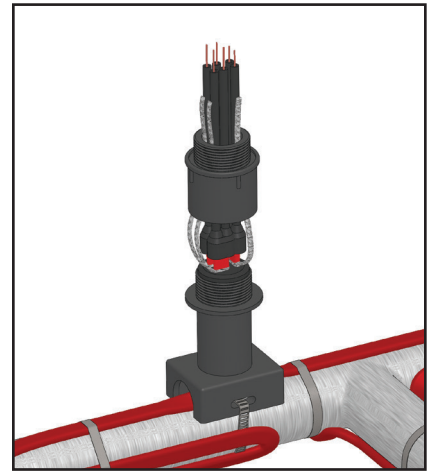

9. Slide compression fitting over cable. Grommet should be placed inside pipe standoff. Termination boot should be spaced 1/2" from sealing grommet. Tighten compression fitting until it bottoms out against pipe standoff.

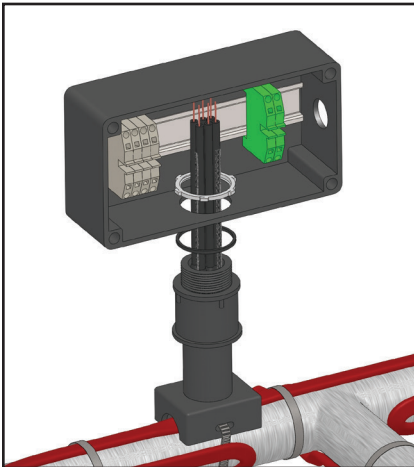

10. Assemble junction box to compression fitting as shown. Tighten locknut until the junction box bottoms out against the lip of the compression fitting.

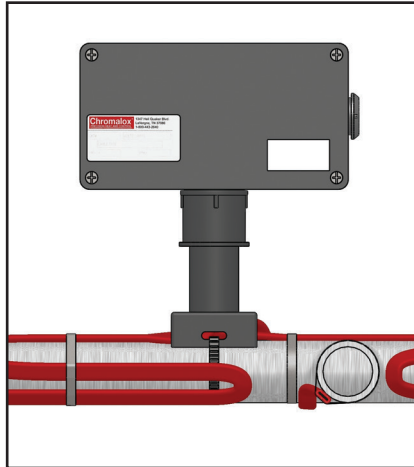

11. Once Locknut is secure place cover on box and secure the lid to the box by tightly fastening screws.

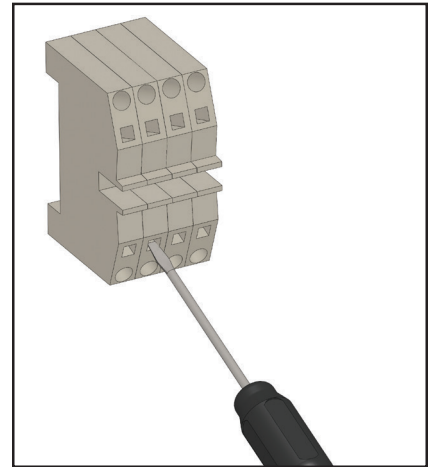

12. Attach 3/4" conduit hub. Use a flat head screwdriver to release the terminal spring clamps and insert cable leads and grounding braid. The UMC multiple entry connection kit can be used as a tee kit or a power connection kit for multiple cables. Please see the electric diagrams below for proper wiring for your application. Attach junction box cover to seal enclosure.

Note: The conduit hub should be approved for Class 1, Div. 2; Class II Div. 1 & 2, Class III, Div. 1 & 2, and NEMA 4X rated by a nationally recognized testing laboratory.

Wiring Diagrams

Tee Connection - Overjacketed Cables

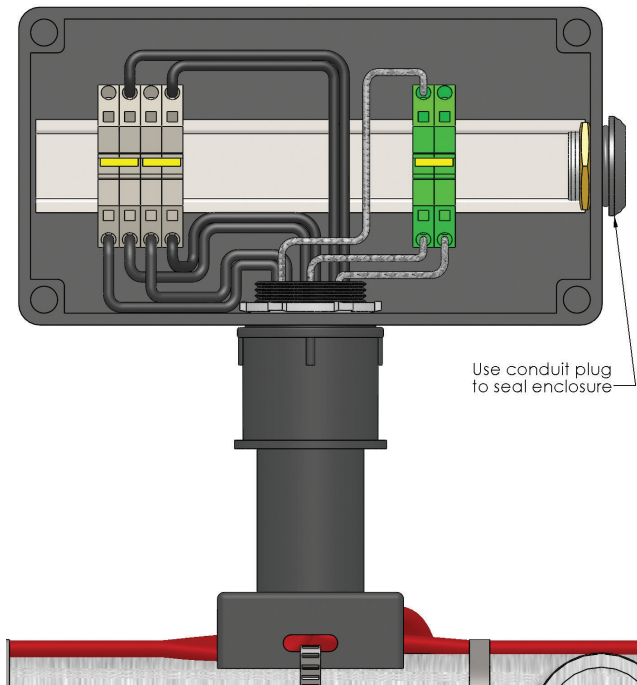

Power Connection - Overjacketed Cables

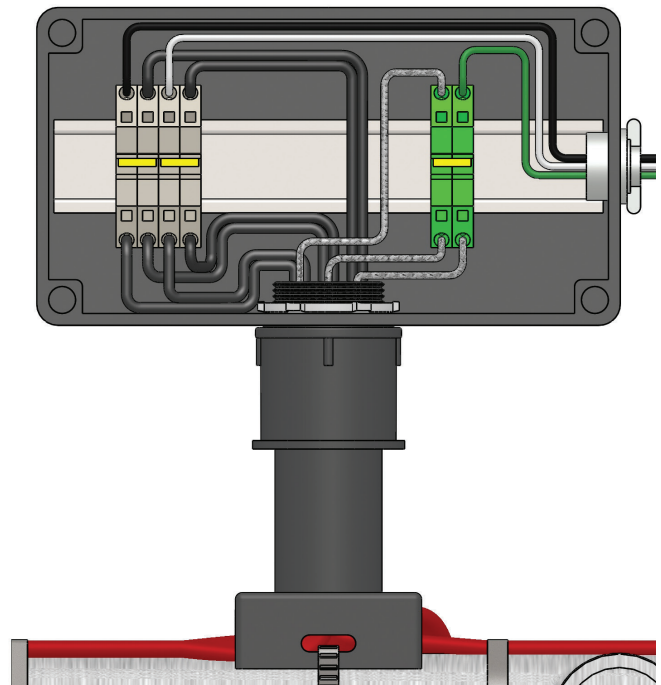

Limited Warranty:

Please refer to the Chromalox limited warranty applicable to this product at http://www.chromalox.com/customer-service/policies/terms_of_sale.aspx.

Chromalox, Inc.
1347 Heil Quaker Boulevard
Lavergne, TN 37086
(615) 793-3900
www.chromalox.com