

Installation, Operation and  
Maintenance Instructions

# CXH-A/B Hazardous Location Forced-Air Heater



PF490CE-4  
161-302421-007  
March 2022

# Table of Contents

- 1. Introduction..... 3
- 2. Safety..... 3
- 3. Specifications and Product Identification..... 4
- 4. Mechanical Installation ..... 6
- 5. Electrical Installation..... 8
- 6. Operation ..... 11
- 7. Preventative Maintenance and Repair ..... 13
- 8. Repair and Replacement ..... 14
- 9. Troubleshooting..... 18

# 1. Introduction

This document contains safety, installation, operation, maintenance, and troubleshooting information for model CXH-A/B unit heaters. Always check [www.chromalox.com](http://www.chromalox.com) to ensure you have the latest revision of this document. Revision date is listed on the cover page.

---

## 2. Safety

### Read this First

Read this document in full prior to installation and commissioning as it contains important safety and warning information that can prevent injury, death, and damage to property. Model CXH-A/B heaters meet the requirements of ATEX directive 2014/34/EU and IECEx schemes. They are designed for space heating and freeze protection in hazardous locations where potentially flammable gasses may be found.

**Routine preventative maintenance is required to ensure safe and reliable operation.**

### Qualified Personnel

Installation and servicing should be performed by qualified personnel only. Qualified personnel should be familiar with electrical installations in hazardous locations. Installation should be in accordance to the latest issues of the relevant parts of EN60079 as well as local codes.

### **⚠ WARNING**

***ELECTRIC SHOCK HAZARD. Disconnect all power before installing or servicing heater. Failure to do so could result in personal injury or property damage.***

### Flameproof Enclosures

Only remove enclosure covers when it can be confirmed that flammable gases or dust are not present.

**Flameproof Enclosures:** This heater is designed for use in hazardous locations and contains enclosures with flameproof joints. Unless otherwise noted, do not tamper with, repair, or modify enclosures or the enclosures flameproof joints. If the flameproof joints (threads or machined surfaces) appear to be damaged, units must be returned to Chromalox for repair. If stripped or damaged, replacement fasteners used on flameproof enclosures must be provided by Chromalox.

**Indicator Lights:** If the lens becomes damaged or detached then the Indicator Lamp should be replaced.

### Hot Surfaces

During operation, surfaces of the heater may become hot and pose a potential burn risk. Prior to inspecting or servicing wait until surfaces have cooled below 40°C.

### Motor and Fan Blade

Motor and fan blade rotate at high speed during operation. Never remove protective grill during operation. Before servicing ensure that blade and motor have come to a complete stop.

When stored or used at -40°C, inspect the motor prior to and after use .

### Noise Levels

During operation, model CXH-A/B heaters produce noise levels of approximately 82dB. It is recommended that personnel working in close proximity to operating equipment be equipped with hearing protection to prevent hearing damage or loss.

### Glycol Heat Transfer Fluid

Model CXH-A/B heater utilize propylene or ethylene glycol in the sealed heat exchanger. Material Safety Data Sheets (MSDS) can be located at [www.chromalox.com](http://www.chromalox.com).

### Electrostatic Charging Hazard

The accumulation of dust and dirt on painted heater surfaces can potentially lead to electrostatic charging. Per preventative maintenance and repair section, only clean painted surfaces with a wet, damp cloth.

# 3. Specifications and Product Identification

Table A - Operating Performance

Model	kW	Voltage and Phase	Horiz. Air Discharge (ft.)	BTUH	CFM (m <sup>2</sup> /hr)	Wt. Kg. (Lbs.)	Overall Dimensions mm (In.)			5/8" UNC Tapped Mounting Hole Locations mm(in.)	
							A	B	C	D	E
CXH-A/B-03S	3	380/400/415V 3ph 50Hz 208/240V-1 or 3ph 60Hz 480/575V 3ph 60Hz	28 (8.5)	10,236	700 (1189)	58 (127)	485.8 (19-1/8)	606.4 (23-7/8)	533.4 (21)	88.9 (3-1/2)	346.1 (13-5/8)
CXH-A/B-05S	5	380/400/415V 3ph 50Hz 208/240V-1 or 3ph 60Hz 480/575V 3ph 60Hz	28 (8.5)	17,060	700 (1189)	58 (127)	485.8 (19-1/8)	606.4 (23-7/8)	533.4 (21)	88.9 (3-1/2)	346.1 (13-5/8)
CXH-A/B-07S	7.5	380/400/415V 3ph 50Hz 208/240V-1 or 3ph 60Hz 480/575V 3ph 60Hz	32 (9.8)	25,590	840 (1427)	60 (133)	485.8 (19-1/8)	606.4 (23-7/8)	533.4 (21)	88.9 (3-1/2)	346.1 (13-5/8)
CXH-A/B-10S	10	240V-1 or 3ph 480/575V 3ph 60Hz	32 (9.8)	34,120	840 (1427)	63 (138)	485.8 (19-1/8)	606.4 (23-7/8)	533.4 (21)	88.9 (3-1/2)	346.1 (13-5/8)
CXH-A/B 10M	10	380/400/415V 3ph 50Hz	47 (14.3)	34,120	1450 (2464)	68 (150)	635 (25)	708 (27-7/8)	533.4 (21)	111.9 (4-13/32)	447.7 (17-5/8)
CXH-A/B-15M	15	380/400/415 V 3ph 50Hz 208/240/480/575V 3ph 60H	47 (14.3)	51,180	1450 (2464)	68 (150)	635 (25)	708 (27-7/8)	533.4 (21)	111.9 (4-13/32)	447.7 (17-5/8)
CXH-A/B-20M	20	380/400/415V 3ph 50Hz 480/575V 3ph 60Hz	43 (13.1)	68,240	1450 (2464)	75 (165)	635 (25)	708 (27-7/8)	533.4 (21)	111.9 (4-13/32)	447.7 (17-5/8)
CXH-A/B-25L	25	380/400/415V 3ph 50Hz 480/575V 3ph 60Hz	54 (16.5)	85,300	2330 (3959)	91 (200)	816 (32-1/8)	809.6 (31-7/8)	552.5 (21-3/4)	139.7 (5-1/2)	549.3 (21-5/8)
CXH-A/B-30L	30	380/400/415V 3ph 50Hz 480/575V 3ph 60Hz	54 (16.5)	102,360	2330 (3959)	91 (200)	816 (32-1/8)	809.6 (31-7/8)	552.5 (21-3/4)	139.7 (5-1/2)	549.3 (21-5/8)
CXH-A/B/-35L	35	480/575V 3ph 60Hz	54 (16.5)	119,420	2330 (3959)	91 (200)	816 (32-1/8)	809.6 (31-7/8)	552.5 (21-3/4)	139.7 (5-1/2)	549.3 (21-5/8)

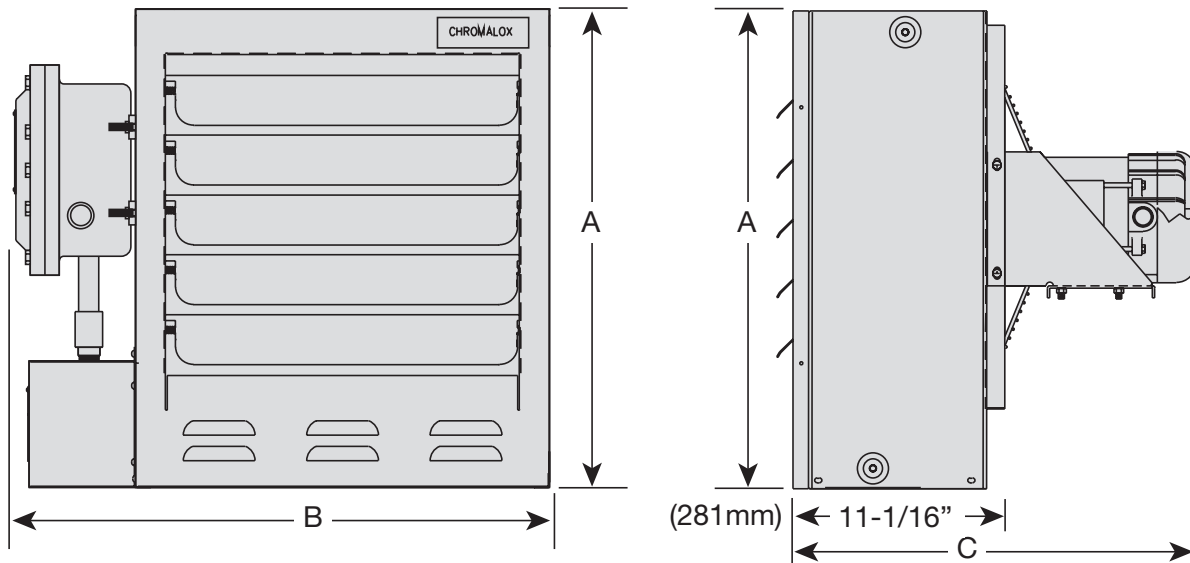

Note: Performance data is based on results of controlled testing. Actual performance may vary depending on application.

**Table C - Specifications**

Standard CXH-A/B Models	ATEX	Ex II 2 G Ex db IIB T3 Gb -40°C ≤ T <sub>amb</sub> ≤ +40°C (-40°F ≤ T <sub>amb</sub> ≤ +104°F)
	IECEX	Ex d 118 T3 Gb -40°C ≤ T <sub>amb</sub> ≤ +40°C (-40°F ≤ T <sub>amb</sub> ≤ +104°F)
	EAC Ex	1 Ex de IIB T3 X -40°C ≤ T <sub>amb</sub> ≤ +40°C (-40°F ≤ T <sub>amb</sub> ≤ +104°F)
Mechanical	Cabinet	Powder Coated Carbon Steel
	Enclosures	Flame-proof, Aluminum
	Fan Guard	Finger safe, welded wire
	Heat Exchanger	ASME Designed, Carbon Steel
	Fan Blade	High Performance Aluminum
	Conduit	Galvanized, Heavy Walled
	Pressure Relief Valve	316 Stainless Steel, Preset
Electrical	Immersion Heater	High grade nickel chromium resistance wire encased in copper sheath
	High Limit Cutout	Manual Reset or Optional Automatic Reset
	Control Transformer	Class II, 40VA
	Control Contactor	Heavy Duty Definite Purpose
	Motor Protection	Thermal Protector
	Optional Thermostat	Flame-proof, 50-90°F (10-32°C)
	Optional Pilot Lights	Indicates Heat-on, Heater Fault
Temperature Limitations	Operating	-40°C to + 40°C (-40°F to 104°F);
	Storage	Intermittently to 130°C (266°F)

Model CXH-A/B heaters have an EC type examination as well as IECEX and EAC certificates issued by Intertek and have been approved to the following standards

- EN 60079-0:2012+A11:2013
- EN 60079-1:2014
- IEC 60079-0:2011 (Ed. 6)
- IEC 60079-1:2007-04 (Ed. 6)

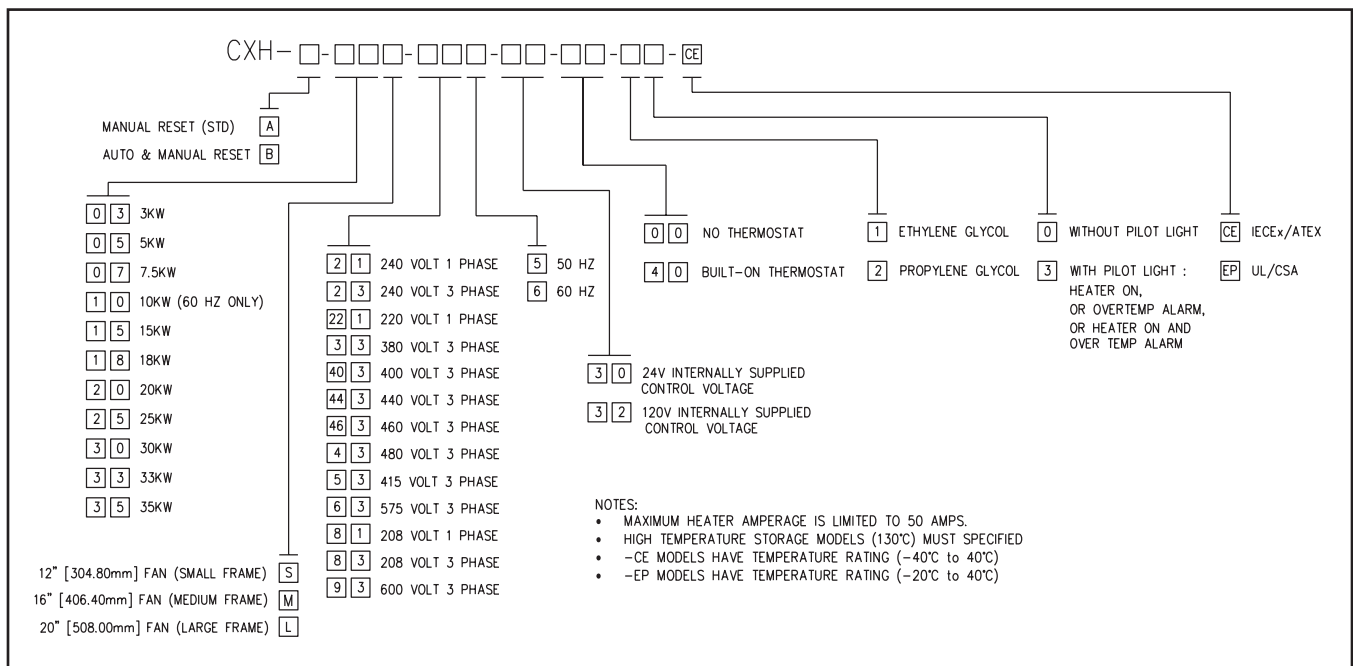

# 4. Mechanical Installation

## Location

1. Model CXH-A/B heaters are certified for hazardous locations listed in table C. When un-crating confirm nameplate (located on control enclosure lid on left side of heater) matches what was ordered. If listing does not meet hazardous location requirements, contact Chromalox immediately.
2. Prior to installation ensure that heater configuration meets environmental requirements. Model CXH-A/B heater are designed with corrosion and moisture protection, but it is the responsibility of the end user to ensure that materials are compatible with the application conditions.
3. Location should be free of interference from columns, machinery and partitions, and should allow for required clearances (see Mounting).
4. Outlet air is hot, so avoid locations where heaters may blow directly at personnel.
5. For best performance, locate heaters according to figure 1. This will promote optimal air circulation and eliminate hot or cold spots. Heaters should blow air parallel to exposed walls (do not blow directly at and should be installed along the windward side when installed in a building exposed to a prevailing wind).

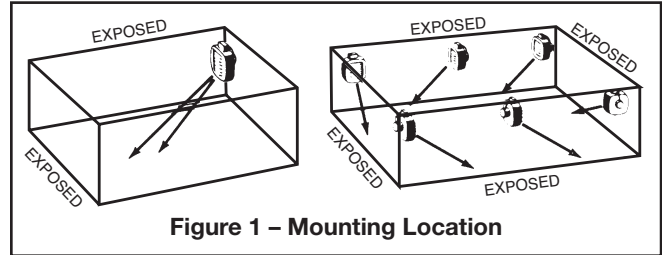

## Mounting

1. Model CHX-A/B heaters are designed for use only in a permanently mounted upright position. The maximum out of plane dimensions as shown in Figure 2 must not be exceeded in either direction during operation and installation. Failure to comply may cause nuisance tripping of over-temperature cutout.
2. The ceiling or wall mounting surface and the anchoring must be sufficient to support the combined weights of the heater and mounting hardware (heater weights are listed in Table A).
3. Heaters may be mounted at any convenient height above floor. The minimum spacing shown in Figure 3 should be maintained to adjacent walls and ceiling. If floor heat is desired, do not mount higher than 8 to 10 feet (2.4 to 3.0 meters) above floor.
4. Controlling thermostats to individuals should be mounted at shoulder height on inside walls or columns clear of the discharge air stream of the unit. Allow at least 4 feet (1.2m) in front of heater for air stream to discharge freely. Do not mount mercury type thermostat directly on unit, vibration could cause malfunction.
5. Heater may be mounted on a shelf or stand from the bottom. Be sure that mounting clearances are maintained and that bottom of unit has at least 1" (25mm) clearance underneath it. This is necessary for good air circulation and servicing of heat exchanger. All mounting methods must allow for removal of front cover.
6. Mounting and anchoring provisions must take into account the unit vibration and cantilevered loading when wall or pole mounted. Heater weights are listed in tables A and B within the Specifications and Product Identification section of the manual.
7. For proper mounting support, it is recommended that a Chromalox supplied wall, ceiling, or pole mounting kit be utilized. These kits include brackets and heater installation hardware. Refer to document PF458 for mounting kit installation.
8. CXH-A/B heaters are equipped with two threaded mounting points (5/8-11 UNC) located on the top of the heater case that may be used to anchor the heater to an alternative mounting structure using 5/8-11 (UNC) bolts and lock-washers.

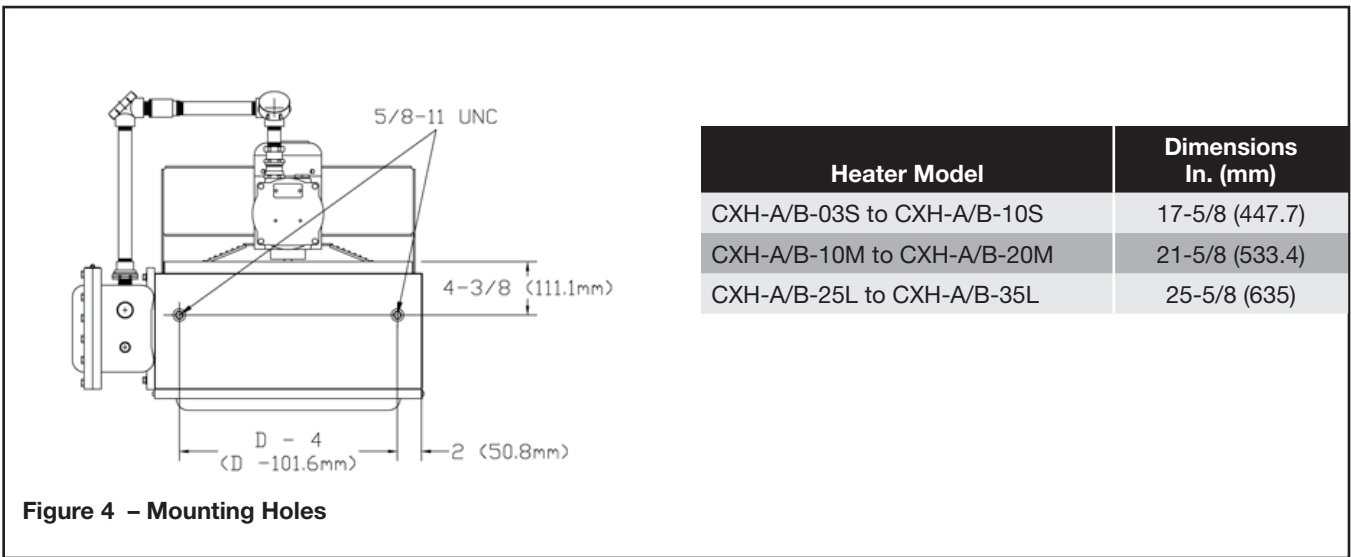
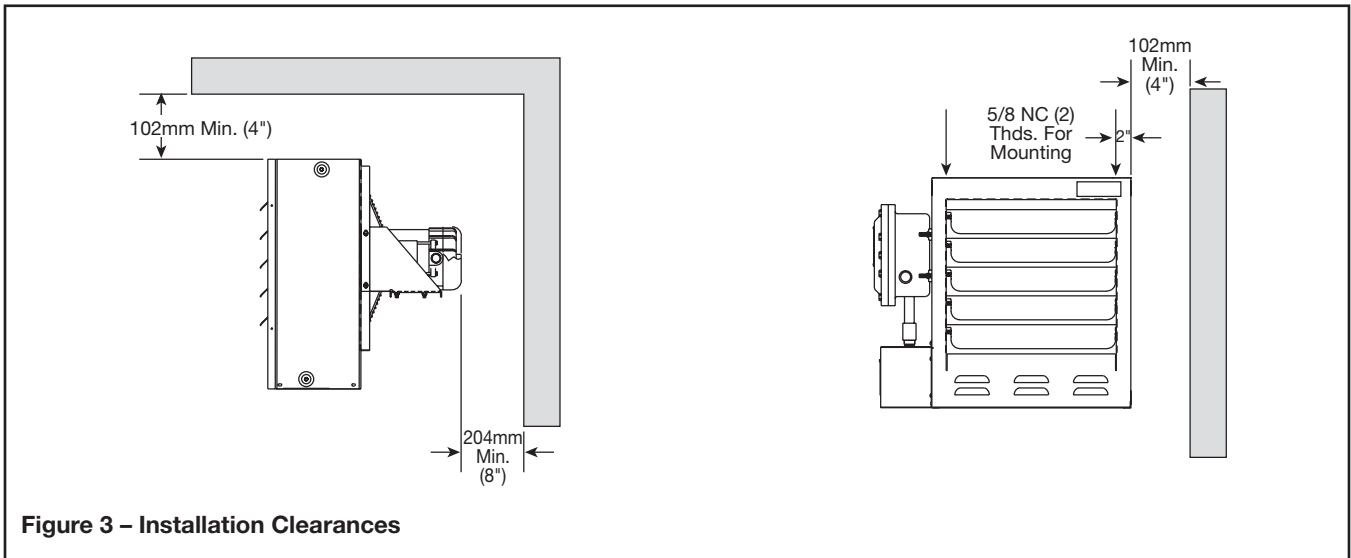
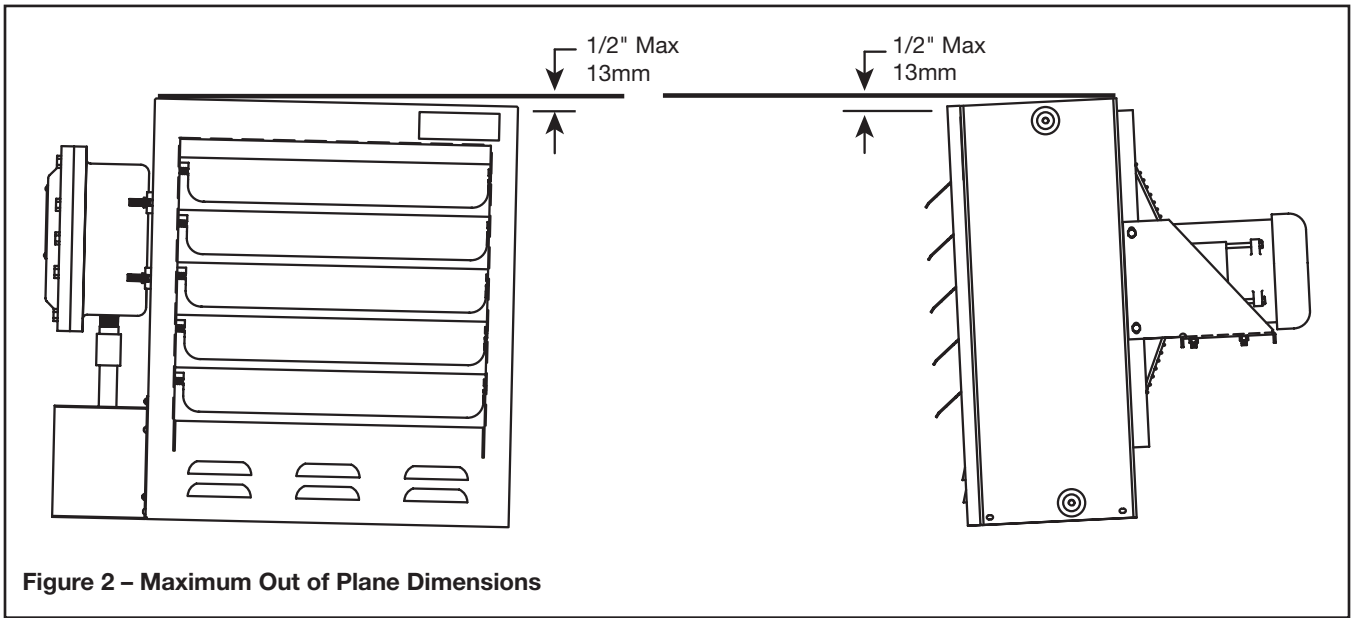

Heater Model	Dimensions In. (mm)
CXH-A/B-03S to CXH-A/B-10S	17-5/8 (447.7)
CXH-A/B-10M to CXH-A/B-20M	21-5/8 (533.4)
CXH-A/B-25L to CXH-A/B-35L	25-5/8 (635)

# 5. Electrical Installation

## Prior to Installation

1. Follow all safety guidelines in this manual when performing electrical wiring. Electrical installation should be conducted by qualified personnel.
2. Model CXH-A/B heaters must be installed according to the latest editions of the relevant parts of EN60079.
3. Disconnect power to unit prior to installation. If integral disconnect is being serviced, ensure that feeder service to disconnect is off.
4. Familiarize yourself with wiring diagram and wire connection points. Wiring diagrams are located on the inside cover of the main control enclosure. A general wiring diagram is also included in this manual.
5. Ensure that proper cable glands and conduit connectors have been selected. Cable, glands and conduit must be installed per IEC/ATEX guidelines and must have proper hazardous location listings.
6. 1”NPT Entry on top is factory equipped with a non-certified conduit plug
7. Unused conduit/cable entries must be plugged with certified stopper plugs.
8. Ensure that equipment is properly grounded using designated grounding lugs.
9. Modification of cable/conduit entries will void third party listings and warranty.
10. Wiring should be selected based on amperages listed in table D. Use only copper conductors and approved wiring methods.
11. An external overcurrent device is required. Overcurrent device should be sized based on heater amperages listed in table D and should conform to installation location requirements.

## Mains Connection

1. The conduit / cable entry for mains power are located on the cast control enclosure.
2. To access the connection points for the mains power, remove the (18) x M12 cover bolts on the main enclosure. Once removed, the (3) mains wires should be connected directly to the heater contactor or circuit breaker (if equipped). See figures 5 and 6 for connection points.

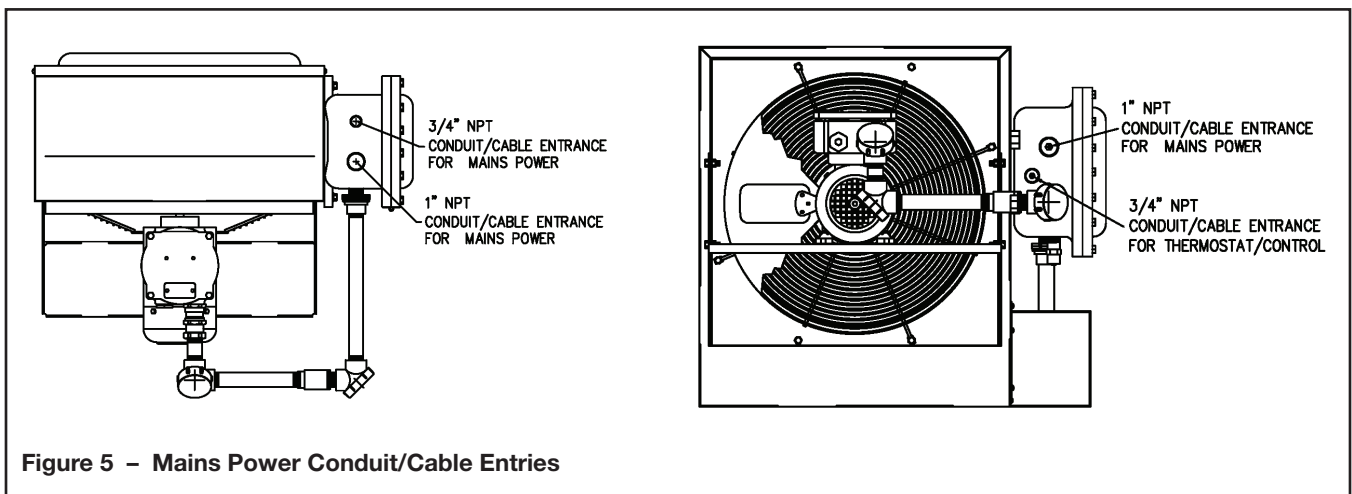
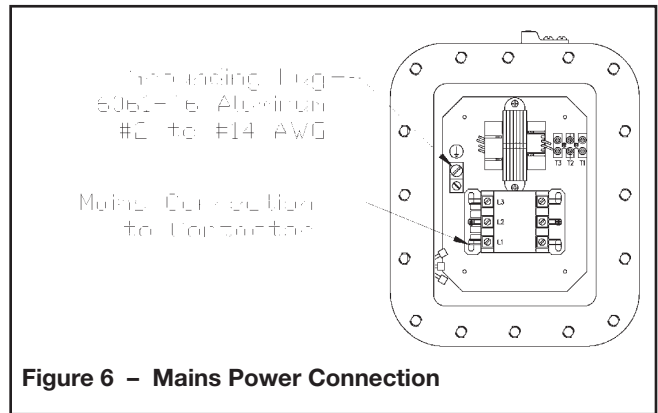

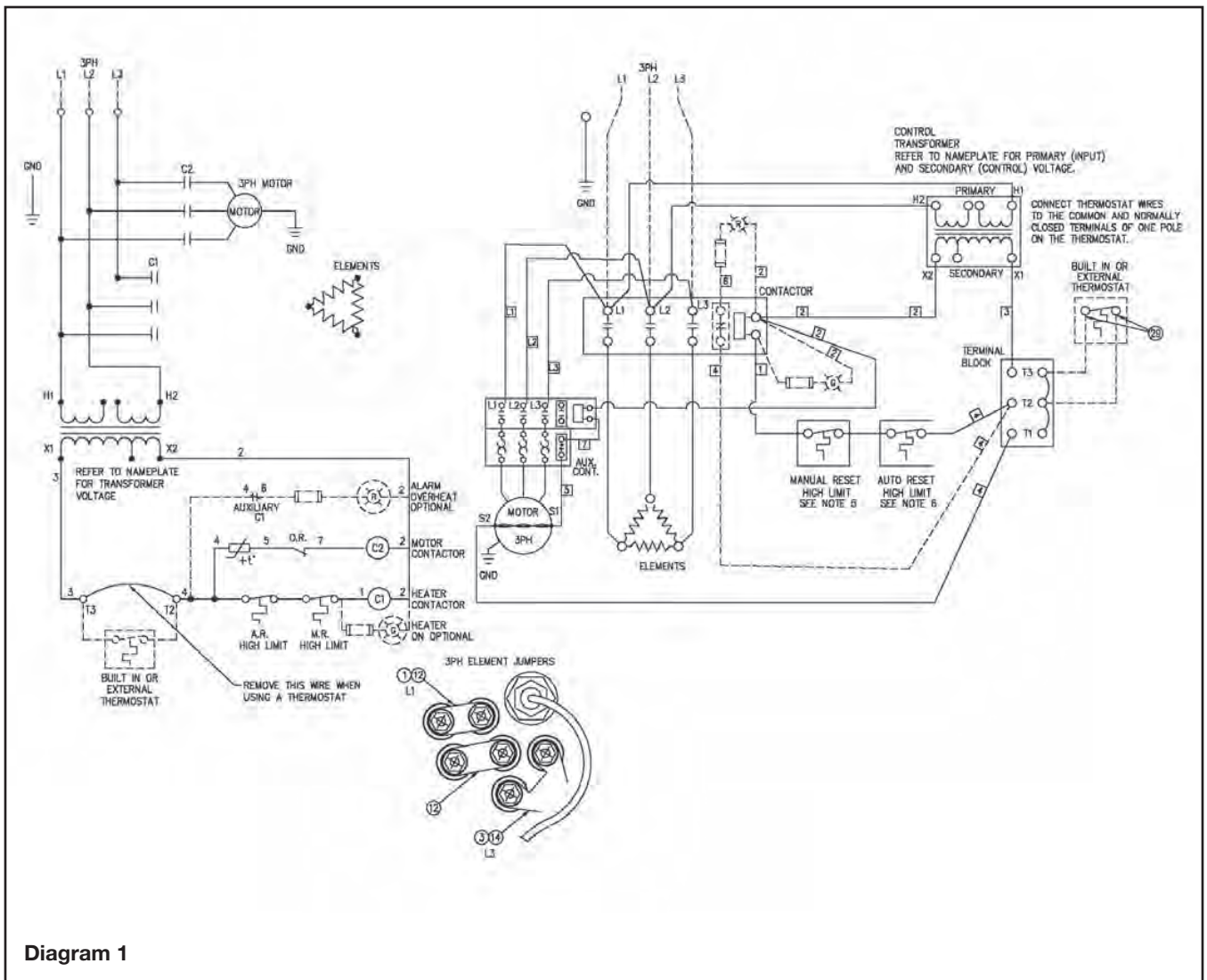

Diagram 1

**Table D – Electrical Ratings**

Model	Volts	kW	Phase	Total Current (Amps)	Minimum Circuit Amps	Supply Wire (AWG) (90°C Ambient)	Max. Fuse/ Breaker size (Amps)	Wiring Diagram
CXH-A/B-03	240	3	3	8.0	10.0	14	15	I
CXH-A/B-05	240	5	3	12.8	16.0	14	20	I
CXH-A/B-07	240	7.5	3	17.6	22.0	12	25	I
CXH-A/B-10	240	10	3	24.8	31.0	8	35	I
CXH-A/B-15	240	15	3	36.9	46.2	6	50	I
CXH-A/B-03	480	3	3	4.0	5.0	14	15	I
CXH-A/B-05	480	5	3	6.4	8.0	14	15	I
CXH-A/B-07	480	7.5	3	8.8	11.0	14	15	I
CXH-A/B-10	480	10	3	12.4	15.5	14	20	I
CXH-A/B-15	480	15	3	18.5	23.2	10	30	I
CXH-A/B-20	480	20	3	24.5	30.7	8	35	I
CXH-A/B-25	480	25	3	30.9	38.7	8	40	I
CXH-A/B-30	480	30	3	36.9	46.2	6	50	I
CXH-A/B-35	480	35	3	42.9	53.7	4	60	I
CXH-A/B-03	600	3	3	3.2	4.0	14	15	I
CXH-A/B-05	600	5	3	5.6	7.0	14	15	I
CXH-A/B-07	600	7.5	3	7.5	9.4	14	15	I
CXH-A/B-10	600	10	3	10.4	13.0	14	15	I
CXH-A/B-15	600	15	3	15.2	19.0	14	20	I
CXH-A/B-20	600	20	3	20.0	25.0	12	25	I
CXH-A/B-25	600	25	3	24.7	30.9	8	35	I
CXH-A/B-30	600	30	3	29.6	37.0	8	40	I
CXH-A/B-35	600	35	3	34.4	43.0	6	50	I

## 6. Operation

### General

1. The CXH-A/B unit heaters use a sealed water-glycol filled heat exchanger. The electric immersion elements transfer heat energy directly to the fluid generating a fluid/vapor mixture which releases its heat energy to the finned radiator as it rises and condenses back to the bottom reservoir to be reheated. This cycle will continue as long as fan forced air is available on the finned structure to remove the heat to the airstream.
2. The finned structure of the heat exchanger must be kept clean and free of accumulated dust and dirt. The cabinet front panel is easily removed providing access to the heater core for periodic cleaning.
3. Unit should not be operated with louvers fully closed. Mechanical stops are incorporated into the design of the cabinet to limit the degree of closure. Do not force the louvers beyond these stops.
4. If specified, units are supplied with built in alarm pilot lamps which will energize when abnormal conditions occur. Review troubleshooting section for information on addressing these situations.
5. Do not operate in ambient temperatures exceeding 40°C (104°F).

---

### Startup

1. Prior to startup, ensure that heater has been properly installed per this manual and local requirements.
2. When starting up after long period of in-operation, ensure that proper maintenance procedures have been performed. Not following preventative maintenance procedures can lead to potential dangerous operating conditions.
3. Stand clear of front of heater to avoid possible injury.
4. Unless fitted with the optional 3 position selector switch, heater should immediately start once power is supplied.
5. In temperatures below -20°C, the fan may not begin rotating for several seconds. This is normal as the motor and heat exchanger must heat up the entire unit in order for it to begin rotating.

---

### Manual and Automatic Reset Thermal Cutout

1. **High temperature cutout(s) must never be bypassed in control circuit. The factory must perform the replacement of the immersion heater or high temperature cutout. The heat exchanger seal must not be broken. Consult factory for service.**
2. Resetting the manual cutout multiple times without resolving the cause of the tripping may allow the heater to operate in an unsafe condition. Failure to investigate and resolve a trip condition could result in personal injury or property damage.
3. The automatic and manual reset limit controls are located in the heating element hazardous location enclosure on the heat exchanger which is covered by the sheet metal housing attached to the side of the unit.
4. To gain access, remove the four sheet metal screws holding the sheet metal cover in place and unthread the cast aluminum enclosure lid.
5. The manual reset limit control device has a small reset button protruding from the center of its back housing.
6. Depress this button in to reset the control. Replace the aluminum enclosure lid and sheet metal cover.
7. The automatic reset limit control does not require resetting. If nuisance tripping occurs, consult maintenance and troubleshooting sections. **Do not try to remove or replace.**

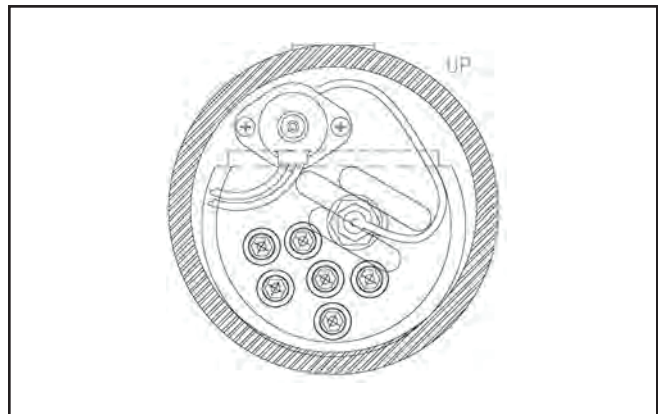



# 7. Preventative Maintenance and Repair

## General

1. Review all guidelines as well as safety and warning information before performing maintenance and repairs.
2. Maintenance and repairs should be performed by qualified personnel only.
3. Improper maintenance or repair can result in injury and destruction of property and may result in warranty becoming null and void.
4. Disconnect unit from power before performing repairs
5. If during inspection, damage to threaded entries and/or flame paths is located, ***do not repair***. Take unit out of service immediately and contact Chromalox to schedule service.
6. Fan Motor bearings are permanently lubricated and do not require maintenance.

## Preventative Maintenance Recommendations

		Frequency			
	Action	Annually	Monthly	Every 3 Months	Every 6 Months
1	Using compressed air, clean off motor, fan, heat exchanger, louvers and interior of heater case.	X		X	
2	Check relief valve and heat exchanger welds for leaks or cracks. If leakage or cracks has occurred, replace heat exchanger immediately.	X	X		
3	Check motor for smooth operation.	X		X	
4	Check enclosure covers and conduit / cable connections	X		X	
5	Inspect enclosures for debris or foreign material, that could potentially cause shorting.	X		X	
6	Inspect all electrical wiring and connections, including terminals, crimps, and wire insulation. Feel for loose connections and look for signs of loose connections, such as discoloration of terminals or wire insulation.	X		X	
7	Check heating element resistance and insulation resistance (MegOhm). See document PF506 for more information.	X			

# 8. Repair and Replacement

## Replacing the Heat Exchanger

Depending on model, heat exchanger weighs between 50 - 100lbs (approx. 25-50kg) and must be properly supported from bottom during removal.

1. Remove front case panel by removing 5 screws located on perimeter of case.
2. Remove bottom case panel by removing 4 screws attaching it to panel wrapper (2 screws located on back and 1 on each side).
3. Remove heat exchanger terminal box cover by removing 4 screws attaching it to panel wrapper.
4. Remove main control enclosure cover bolts.
5. Inside main control enclosure, disconnect wires entering from bottom (heating element lead wires and cutout lead wires).
6. To detach conduit union, secure outer sleeve and turn inner holding the nut closest to the enclosure. Once the red nut is loose, it can be slid over the conduit and rested on the heater terminal housing. To expose inner sleeve, heat exchanger may need to be lowered slightly away from main control enclosure. See step 7.
7. Support heat exchanger from bottom, then remove 3 bolts that secure heat exchanger to panel wrapper.
8. Lower heat exchanger away from case, while guiding wires out of main control enclosure. It is critical that the conduit seal stay in place and is not disturbed.
9. To install new heat exchanger core, reverse step order. Replacement heat exchanger core will include conduit riser and epoxy seal. The seal must remain in tact to maintain hazardous location listing.



Step 1

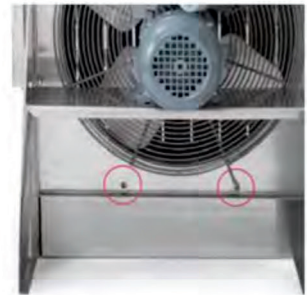

Step 2



Steps 2 and 3



Step 5



Step 6



Step 6



Step 7



Step 7

## Replacing Motor and/or Fan Blade

1. Disconnect the unit from power supply.
2. (Units with motor splice box) Remove 4 bolts and cover of motor splice box
3. (See Figure 12). (Units without motor splice box) Remove 16 bolts and cover of main control enclosure.
4. Note wire connections for future reference and disconnect all wires leading to the motor. All motor wires are permanently marked according to the nameplate on the motor.
5. Remove 4 bolts in motor base holding it to rear cabinet shelf.
6. Remove 4 screws holding fan guard to cabinet.
7. Unthread union at motor wiring outlet nipple connection. Carefully lift the motor, fan blade, and guard off of the cabinet.
8. Note position of fan blade on motor shaft. Loosen the two set screws to remove the fan blade and key from shaft motor.
9. Place guard and fan blade on replacement motor shaft in same locations as original motor. Align key ways in hub and shaft. Insert key flush with fan hub and tighten the two hub set screws.
10. Feed motor wires back into conduit and reposition motor back on unit. Center fan blade in opening and rotate to be sure that it clears housing and guard.
11. Thread motor nipple connection into conduit union and tighten (5 threads minimum). Replace bolts in motor base and reattach fan guard to back of housing in four places. Recheck blade rotation and tighten all hardware.
12. Trim all motor leads extending out of the conduit to 6 lengths. Strip off 3/8" of insulation at cut ends. Using the motor nameplate, previous notes, and marked wires, reconnect the motor for the unit voltage rating as indicated on the heater nameplate. Reattach the ground wire to the connection inside the enclosure. Replace cover and tighten securely.
13. Check fan rotation by momentarily energizing the unit. Air must exit at cabinet front. Reverse any 2 leads at contactor or line supply disconnect to reverse rotation of three phase motor.
14. Removal of fan blade does not require that the motor wiring be disturbed. To clean, service or change the fan blade proceed as follows:
  - A. Remove the four carriage bolts holding the motor base in place on the cabinet platform. Mark the platform to reposition at same location.

- B. Loosen the four screws on the cabinet back holding the fan guard in place.
- C. Pull the motor to the rear extending the conduit connection at the electrical enclosure. Fan blade and hub set screws can now be accessed by tilting the guard rearward at top or bottom back over the motor shell.

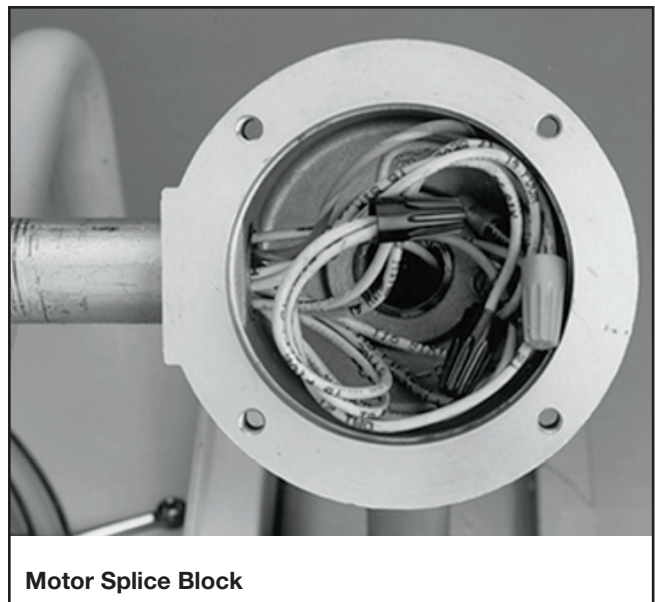
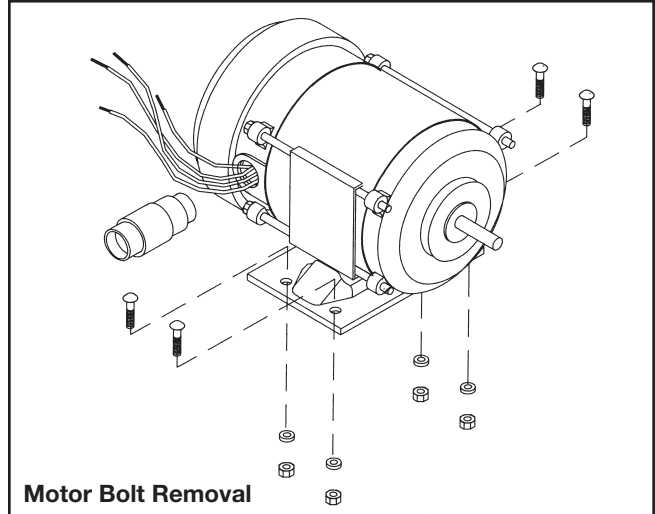

## Flameproof Enclosures

1. Do not attempt to repair any flameproof enclosure joints. If joints or flame paths appear to be damaged contact Chromalox immediately for replacement.
2. If threaded cover bolts or screws are damaged, they must only be replaced with factory provided fasteners.
3. When securing enclosure bolts or screws, hand tighten and follow table E for proper torque spec.

## Flameproof Motor

1. Flameproof joints of the motor are not intended to be repaired. If flameproof joints appear to be damaged, contact Chromalox immediately for motor replacement.
2. The anti-condensation heater can be activated only when the motor is not powered.

**Table E – Flameproof Enclosure Bolt Torque**

Enclosure	Bolt Size	Bolt Grade	Bolt Torque (ft-lbs.)	Bolt Torque (N-M)
Control Enclosure	7/16-14 UNC-2A	SAE 8	52	70.5
Thermostat Enclosure	5/16-18 UNC-2A	SAE 7	18	24.4
Heating Element Terminal Housing	N/A	N/A	N/A	N/A

## Replacing Contactor, Transformer, and Pilot Lights

1. To access electrical components, remove cover of main control enclosure. Remember to follow all guidelines regarding electrical safety in hazardous locations.
2. Before disconnecting any wires, note the wiring configuration and connections to terminal blocks and other equipment.
3. Contactor and transformer use retaining screws attached to a panel plate within enclosure. Once the wires are disconnected, the components can be removed by loosening screws holding them to the mounting plate.
4. To remove pilot lights, unscrew them from the enclosure once wires are disconnected. Pilot lights are equipped with fusing. Fuses must be replaced with equivalent rated models.
5. Only replace electrical components with those that are factory supplied and have an equivalent rating.

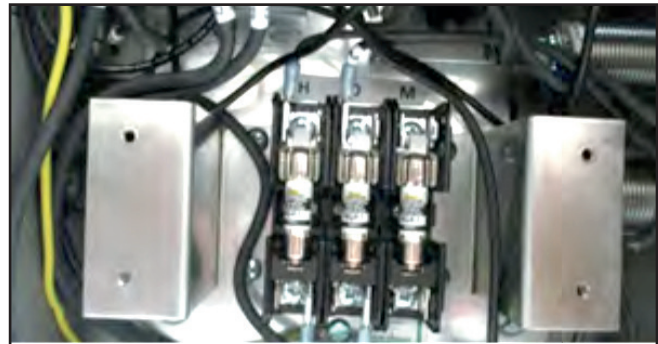

**Fuse Block**

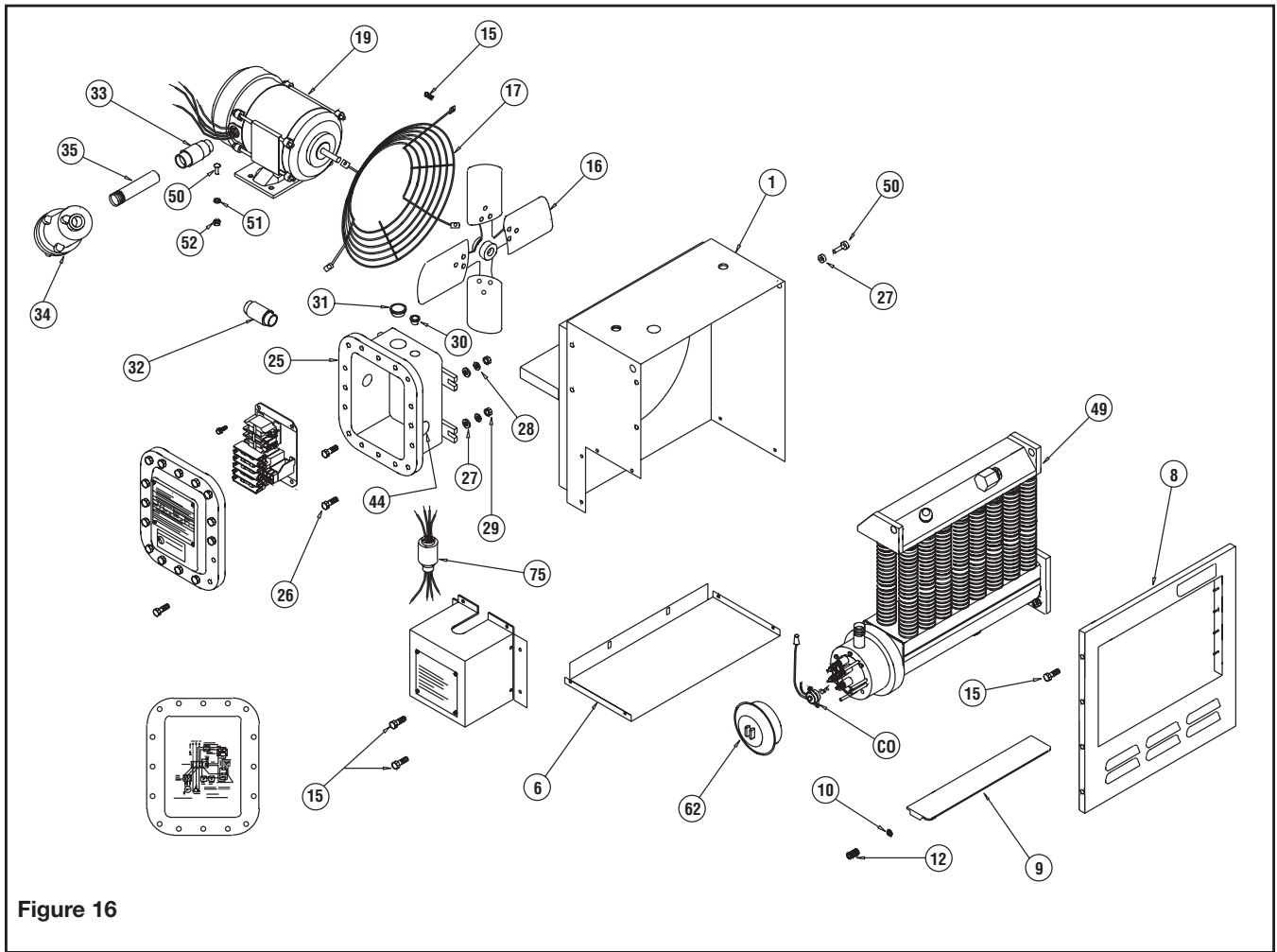

Figure 16

**Common Parts**

Item #	Description	Item #	Description
1	Panel wrapper	28	Washer lock
6	Panel Bottom	29	Hex Nut 3/8-16
8	Panel Front	30	Plug conduit 1/2"
9	Louver	31	Plug conduit 1"
10	Washer Shoulder	32	Union conduit 3/4"
12	Spring	33	Union conduit 3/4"
14	Terminal Box Cover	34	Conduit Box
15	Screw 10-32	35	Conduit 3/4"
16	Fan Blade	50	Bolt 5/16-18
17	Fan Guard	51	Washer
25	Enclosure	52	Nut 5/16-18
26	Bolt 3/8-16, 1.5 lg	62	Cover Exp. Proof
27	Washer flat	75	Conduit 3/4

**Optional Equipment Parts**

Description	Part Number
Thermostat	300-113075-004

Mounting Kit Adapter	
CXH-A/B-03S through 10S	027-302361-001
CXH-A/B-15M through 20M	027-302361-002
CXH-A/M-25L through 35L	027-302361-003

**⚠ WARNING**

**The factory must perform the replacement of the immersion heater or overtemperature cutout. The heat exchanger seal must not be broken. Consult factory for service.**

## 9. Troubleshooting

Condition	Probable Cause	Corrective Action
Unit is not operating or stops operating	Motor has overheated.	Wait 10-15 minutes for motor to cool down
	High Limit Cutout has tripped.	See condition "High limit cutout trips)
Fan is spinning but unit is not putting out heat	Heat exchanger has lost vacuum	Check for signs of vacuum loss, such as leaks near relief valve. If discovered, contact Chromalox and arrange for service.
	Inlet or outlet are blocked	Clean unit using compressed air
	Heat exchanger is dirty	Clean unit using compressed air
	Failed heating element	Contact Chromalox and arrange for service
	Motor may not be spinning at rated rpm	Check motor winding resistance
High limit cutout trips or cycles	Heat exchanger has lost vacuum	Check for signs of vacuum loss, such as leaks near relief valve. If discovered, contact Chromalox and arrange for service.
	Inlet or outlet are blocked	Clean unit using compressed air
	Heat exchanger is dirty	Clean unit using compressed air
Relief valve has activated	Unit has overheated	Contact Chromalox and arrange for service.
Fuse or GFI blows	Short in wiring	Check all wiring for loose or frayed connections and tighten or replace
	Failed heating element	Contact Chromalox and arrange for service.
Large vibration or strange noise coming from heater	Fan-motor is unbalanced	Check to see if set screw is loose. If loose, tighten set screw and ensure fan blade is balanced.
Contactors is chattering (turning on/off rapidly)	Contactors is defective or loose connections / short in wiring	Check for burn marks on the contactors terminals and look for frayed or loose wires. Replace contactors.

### Limited Warranty:

Please refer to the Chromalox limited warranty applicable to this product at <http://www.chromalox.com/customer-service/policies/termsforsale.aspx>.

**Chromalox**  
**103 Gamma Drive**  
**Pittsburgh, PA 15238**  
**(412) 967-3800**  
**www.chromalox.com**