

## Installation Instructions

# CS1 Series Single Phase Solid State Relays



## Important Safeguards

### **⚠ WARNING**

**HIGH VOLTAGE is used in the operation of this equipment; DEATH ON CONTACT may result if personnel fail to observe safety precautions.**

**Learn the areas containing high-voltage connections when installing or operating this equipment.**

### **⚠ WARNING**

**Be careful not to contact high-voltage connections when installing or operating this equipment.**

**Before working inside the equipment, turn power off and ground all points of high potential before touching them.**

### **⚠ WARNING**

**ELECTRIC SHOCK HAZARD: Any installation involving control equipment must be performed by a qualified person and must be effectively grounded in accordance with the National Electrical Code to eliminate shock hazard.**

# CS1 - Single Phase Solid State Relay Power Controller

## General

The CS1 Series of solid state relays are an ideal, low cost power control solution for switching resistive loads found applications in such as furnaces, ovens, heat treating, injection molding, thermoforming, press platens, commercial food equipment, semiconductor, lighting and drying, just to name a few.

### The CS1 Series power controllers feature:

- Rugged, industrial design & touch-safe exterior
- Conservative, continuous service ratings at 40°C
- Up to 120 Amps and up to 600 VAC
- AC and DC Voltage command signals
- Zero cross firing
- Integrated heat sink
- SCR thermal protection with LED indication
- Optional over temperature alarm
- Optional load / line interrupt alarm
- Latching Alarm (DC gated versions only)
- USA & Canadian UL component recognition
- CE conformity

## Installation and Operation

### ⚠ CAUTION

***The owner/installer must provide all necessary safety and protection devices and follow all current electrical wiring standards and regulations. Failure to do so may compromise the integrity of the controller and / or cause product failure resulting in a safety risk to operational and service personnel.***

### ⚠ CAUTION

***This controller utilizes a heat sink which is designed to cool the unit during operation. Under no circumstance should air flow around the controller be compromised in any way. Failure to do so may result in the overheating of the controller, product failure, product temperatures and even fire.***

### ⚠ WARNING

***During continuous operation, the heat sink can reach very high temperatures, and keeps a high temperature even after the unit is turned off due to its high thermal inertia.***

***Higher voltages may be present. DO NOT work on the power section without first cutting out electrical power to the panel. Failure to do so may cause serious injury or death.***

To ensure proper performance, maximum safety and reliability, it is essential to install the unit correctly. This includes proper mounting, spacing, hardware and wiring. See below:

1. Maximum surrounding air temperature is 40°C in "Open Type Equipment" which is suitable for use in pollution degree 2.
2. Install the unit vertically (max 10° inclination from vertical axis).  
Spacing:
  - Minimum vertical distance between unit and panel wall: 3.94" (100 mm)
  - Minimum horizontal distance between unit and panel wall: .79" (20 mm)
  - Minimum vertical distance between adjacent power control units: 11.81" (300 mm)
  - Minimum horizontal distance between adjacent power control units: .79" (20 mm)

## Dimensions & Weights

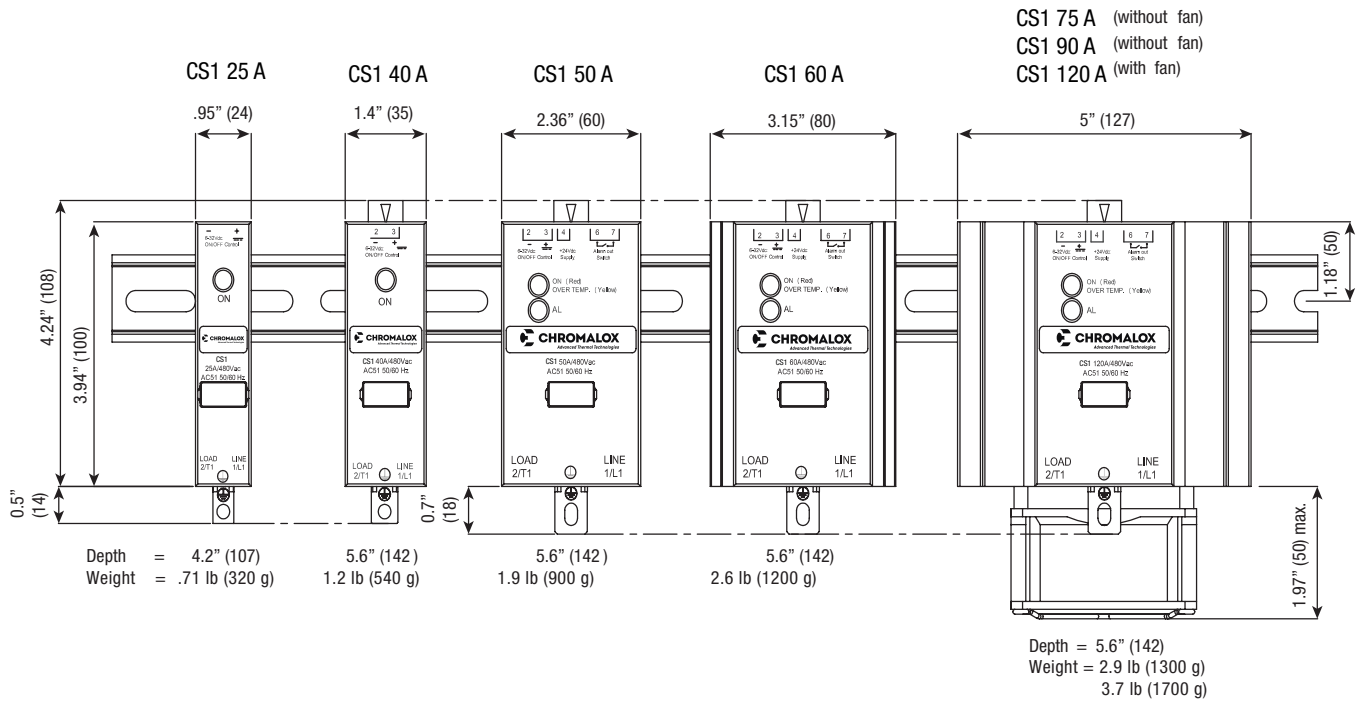

## Control & Power Connection Points & Indication Logic

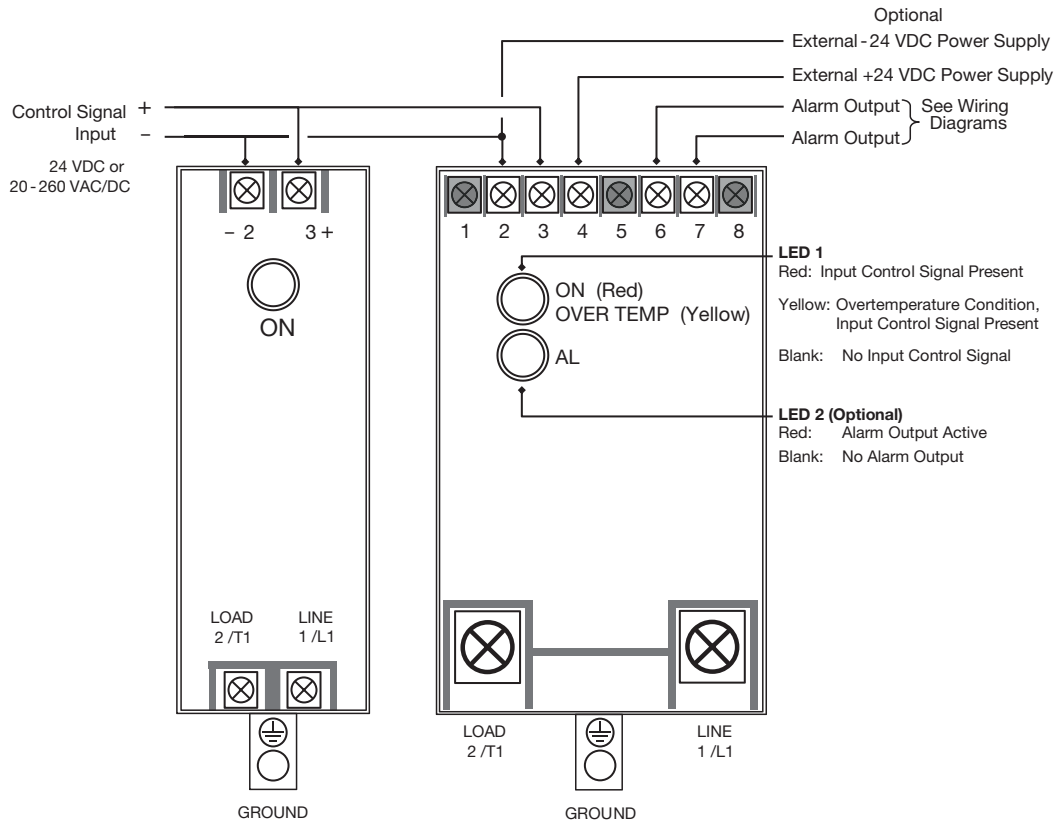

## Control Terminal Description – CS1 Models > 40 Amps

Terminal	Description	24 VDC Input Signal (Type 1) (6 – 32 VDC)	VAC/DC Input Signal (Type 2) (20 – 260 VAC/DC)
1	Not Used		
2	Control Signal Input & VDC Power Supply	Control Signal Input (-) & Optional -24 VDC Power Supply Input	VAC/DC Input
3	Control Signal Input	Control Signal Input (+)	
4	VDC Power Supply	Optional +24 VDC Power Supply Input	Not Used
5	Not Used		
6	Alarm Output	Alarm Options 1 & 2: Solid State Switch	Alarm Option 1: Solid State Switch
7	Alarm Output		
		Alarm Options 3 & 4: Internally connected to Terminal #4 (+VDC Power Supply)	
		Alarm Options 3 & 4: PNP Digital Signal Output	
8	Not Used		

## LED Status Definition

LED	Color	Condition
ON	BLANK	SCR OFF, no Alarm
AL	BLANK	

LED	Color	Condition
ON	RED	SCR ON, No Alarm
AL	BLANK	

LED	Color	Condition
ON	RED	SCR ON, Alarm Output is Active
AL	RED	

LED	Color	Condition
ON	BLANK	SCR OFF, Alarm Output is Active (alarm stored) This condition is only valid with Type "1" input control signal and alarm option.
AL	RED	

LED	Color	Condition
ON	YELLOW	Control Signal is ON, Over Temperature Protection Engaged, SCR is OFF, Alarm Output is Active
AL	RED	

### Notes:

"ON" LED comes standard with ALL CS1 Models

"AL" LED is only available when optional Alarm Output feature is chosen. See order table.

### Single Phase Load

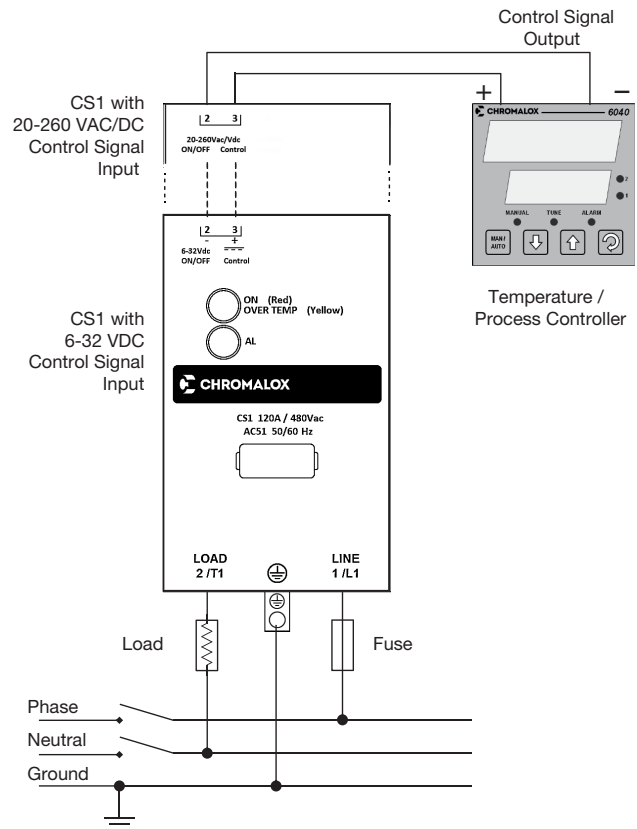

### Controlling 2 Phases (Legs) of a Three Phase (no Neutral) Wye (Star) or Delta Load Configuration

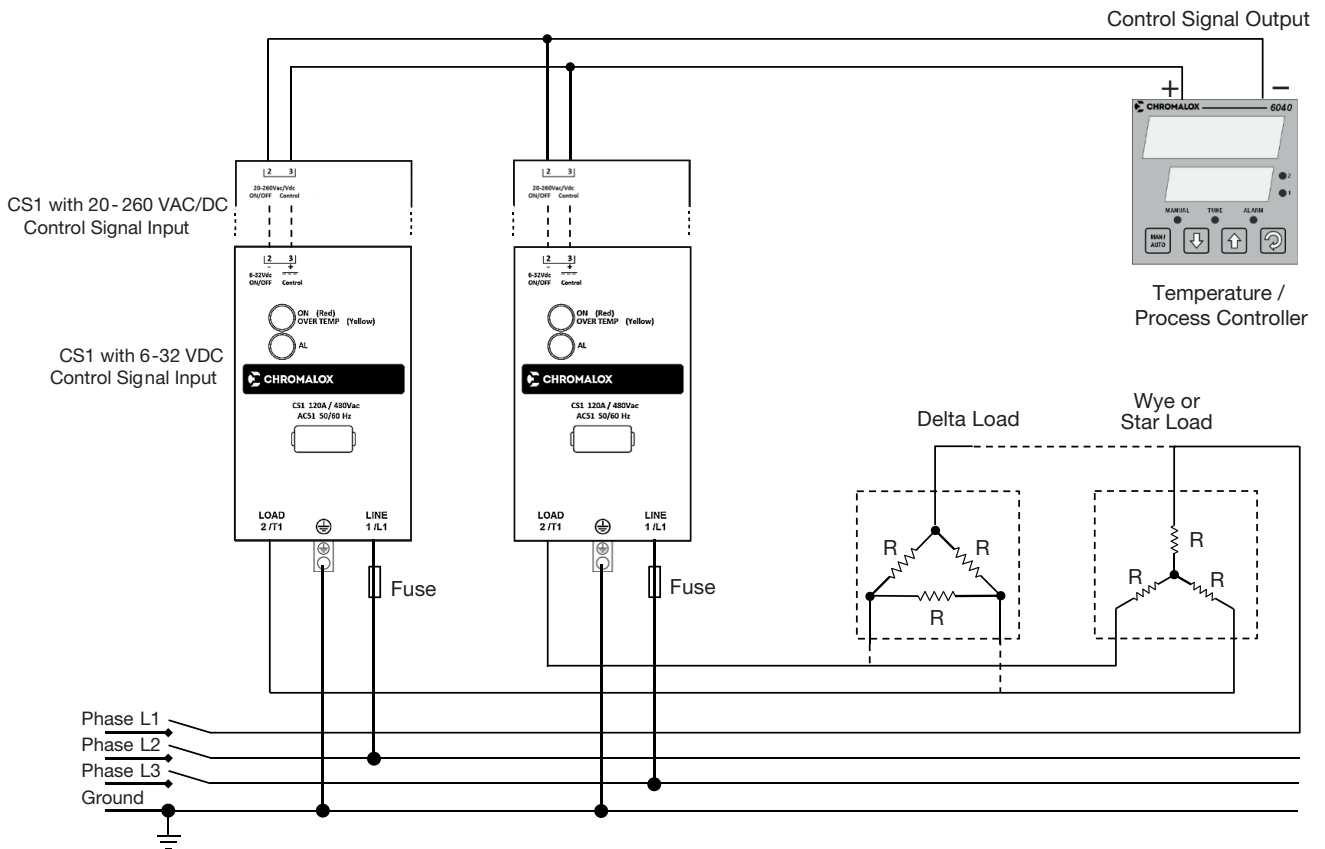

### Three Phase Load in a Wye or Star Connection with Neutral

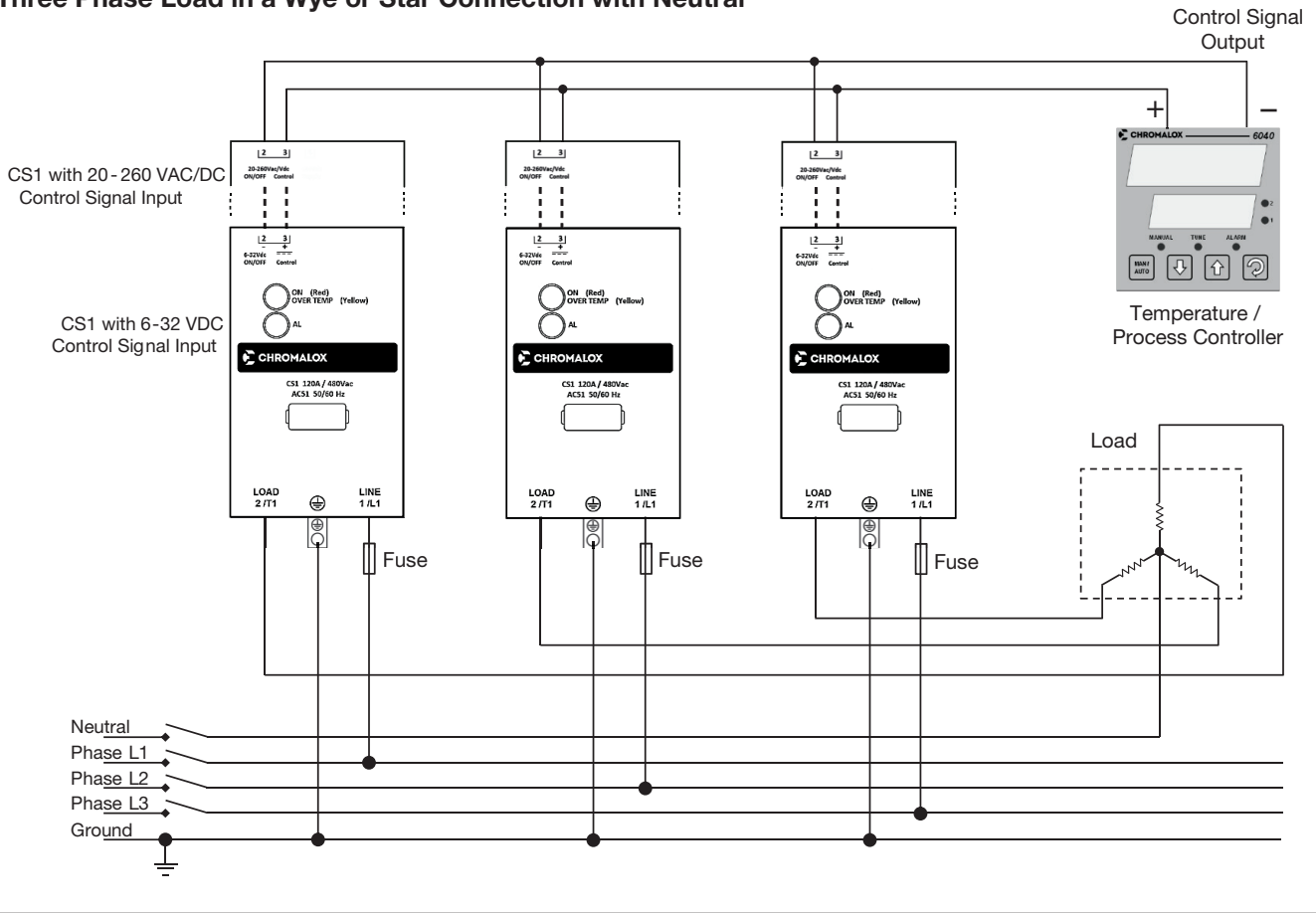

### Optional Alarm Wiring (Alarms available on CS1 Models > 40 Amps)

Control Signal Input: 24 VDC (6 - 32 VDC)  
 Alarm Output: Solid State Switch  
 Alarm Option Code: 1 or 2 (See Order Table)

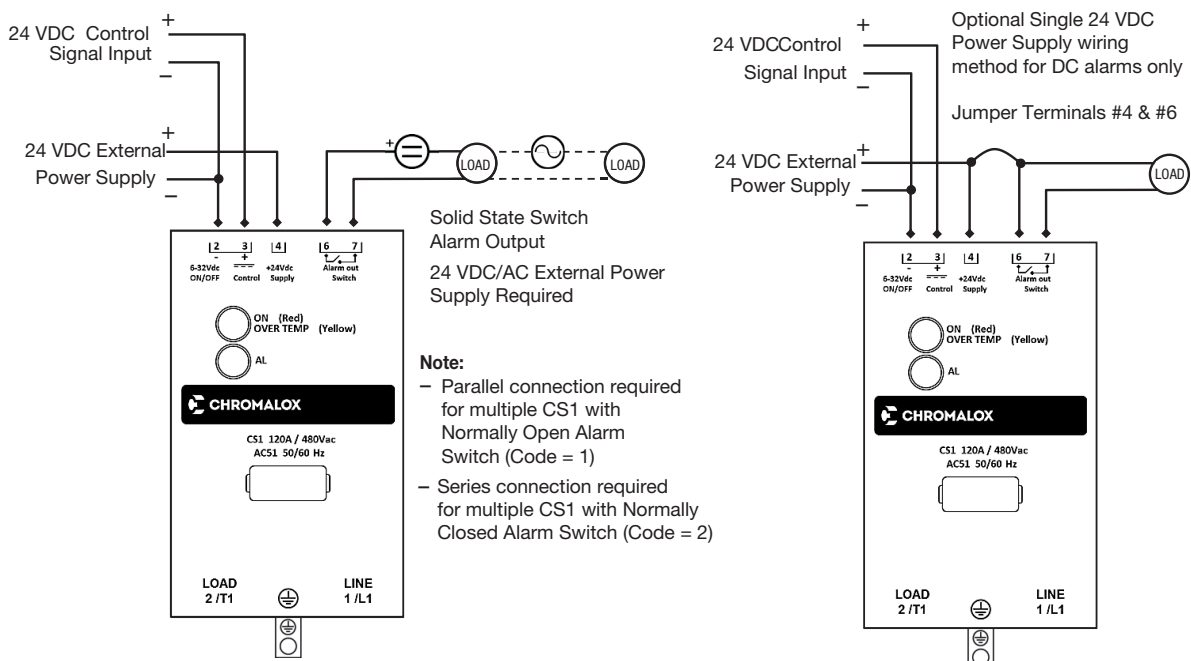

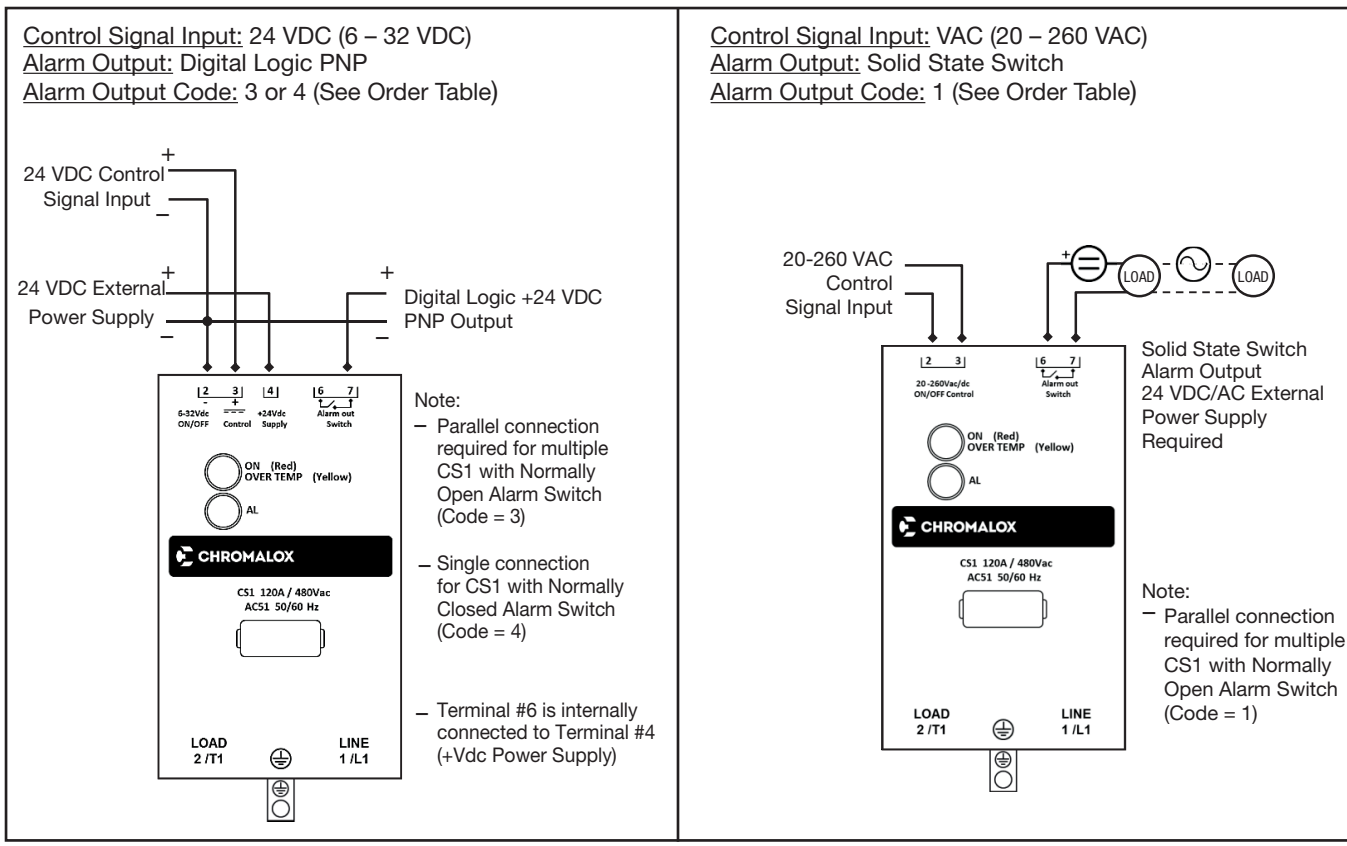

### Specifications

#### General

Category of use: .....AC1  
 Switching Mode: .....Zero Cross  
 Input/Output Isolation Voltage:.....4,000 VAC RMS  
 Operational Voltage Range  
 • 480 VAC models: ..... 24 - 530 VAC  
 • 600 VAC models: ..... 24 - 660 VAC  
 Operational frequency: .....45 - 65 Hz  
 Non-repetitive peak voltage  
 • 480 VAC models: ..... 1200 Vp  
 • 600 VAC models: ..... 1400 Vp  
 Zero Voltage Turn-on: ..... ≤ 20 V  
 Activation time: ..... = 1/2 cycle  
 Deactivation time: ..... = 1/2 cycle  
 Potential drop at rated current: ..... = < 1.4 Vrms  
 Power factor: ..... = 1

#### Inputs

VDC Input (Type “1”)  
 Control voltage: .....6 - 32 VDC  
 Maximum input:..... < 10 mA @32 V  
 Maximum reverse voltage: ..... 36 VDC  
 Activation voltage: ..... > 5.1 VDC  
 Deactivation voltage: ..... < 3 VDC  
 VAC Input (Type “2”)  
 Control voltage: ..... 20 - 260 VAC/DC  
 Activation voltage: ..... > 15 VAC/DC  
 Deactivation voltage: ..... < 6 VAC/DC  
 Current draw: ..... ≤ 8 mAac/dc @ 260 VAC/DC

#### Outputs

Specification	CS1-025	CS1-040	CS1-050	CS1-060	CS1-075	CS1-090	CS1-120
Rated Current (@ 40°C continuous service)	25 A	40 A	50 A	60 A	75 A	90 A	120 A
Max. Surge Current (t=20 ms)	400 A	600 A	1,150 A		1,300 A	1,500 A	
Max. I²t for fusing (blowout)	645 A²s	1,010 A²s	6,600 A²s		8,000 A²s	11,200 A²s	
Critical dV/dt Off-state (min.)	1,000 V/µs						
Off-state Leakage Current (@ Rated Voltage)	< 3 mA						

**Environment Conditions**

Operating Temperature Range: .....0°C to 80°C  
 Maximum Relative Humidity:.....50% @ 40°C  
 Max. Installation Altitude: .....2000 m above sea level  
 Pollution Level: .....2  
 Storage Temperature:..... -20°C to +85°C  
 Junction Temperature:..... 125°C

This device conforms to European Union Directive 2004/108/CE and 2006/95/CE as amended with reference to generic standards:

- EN 61000-6-2 (immunity in industrial environment)
- EN 61000-6-4 (emission in industrial environment)
- EN 61010-1 (safety regulations).

**Alarm Outputs**

The alarms are only available only on models rated at 50 Amps and greater.

There are two types of alarm outputs:

1. Solid State Switch – Controls a connected device for an alarm event, such as a horn or light.
  - a. Requires external 24 VAC/DC power supply
  - b. Ratings:  $I_{max} = 150\text{ mA}$   
 $V_{max} = 30\text{ VAC/DC}$   
 $Z_{close} < 15\ \Omega$  (impedance)  
 $Z_{open} > 1\text{ M}\Omega$  (impedance)
2. Digital Logic – PNP output signal for logic gated devices, such as PLCs
  - a. Requires external 24 VDC (6-32 VDC) power supply
  - b. Ratings:  $I_{max} = 150\text{ mA}$   
 $V_{max} = 30\text{ VAC/DC}$

**Alarm Behavior**

The functionality of the alarm switching varies depending on the type of gating signal

For Models with 24 VDC Input Control Signal

The alarm output function actuates (opens or closes) the isolated solid state output switch (or digital output sig-

nal) when it detects any of the following fault conditions:  
 The control signal is active, but:

- There is no current on the load (zero current or interrupted load)
- There is no line voltage power supply
- The internal temperature limit of the SSR has been exceeded

**Latching Alarm Function**

On the VDC gated CS1 controllers, the alarm state remains latched if the Control Signal is switched off. The Alarm Output will reset (unlatch) once the current load is restored or when the CS1 24 VDC power supply is cycled.

For Models with 20 - 260 VAC/DC Input Control Signal

The alarm output function closes the isolated solid state output switch when it detects any of the following fault conditions:

The control signal is active, but:

- There is no current on the load (zero current or interrupted load)
- There is no line voltage power supply
- The internal temperature limit of the SSR has been exceeded

Latching Note:

On the VAC gated CS1 controllers, in the absence of the control signal, the alarm output is always open. The alarm memory latch function is not possible as with the CS1 with VDC control signal.

**Integrated Thermal Protection**

The SSR temperature is constantly monitored. If the maximum temperature limit (230°F/110°C) is exceeded, current to the load is interrupted and the YELLOW over-temperature condition LED illuminates.

**Derating Curves**

Rated Current versus Ambient Temperature for each CS1 Model

(These curves reflect units tested complete with approved heat sinks and fans, if applicable)

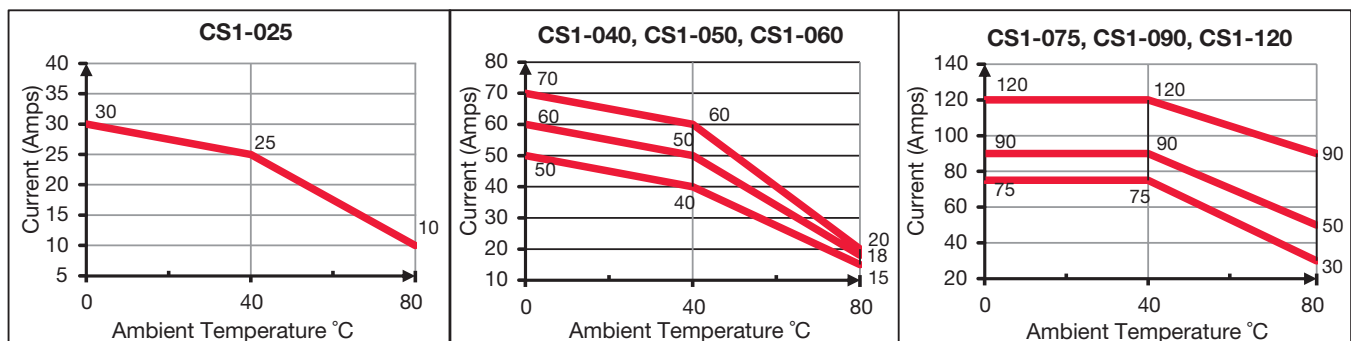

# Ordering Information

## Model Single Phase, Solid State Relay Power Controller - DIN Rail Mount

**CS1** The CS1 Series are DIN Rail mounted, single-phase solid state relays with integrated heatsink for switching resistive loads in industrial applications. Standard features: Zero-voltage turn-on, LED input status indicator, internal over voltage protection (MOV), integrated SCR thermal protection with LED indication<sup>1</sup>, two logic input control signals, operating voltage up to 600 VAC. Optional features: <sup>1</sup>Solid state switch or PNP Digital Signal alarm output during over-heated or interrupted line/load condition. Approvals: CE, UL, cUL

### Code Current @ 104°F (40°C) Ambient, continuous service

<b>025</b>	25 Amps
<b>040</b>	40 Amps
<b>050</b>	50 Amps
<b>060</b>	60 Amps
<b>075</b>	75 Amps
<b>090</b>	90 Amps
<b>120</b>	120 Amps (requires fan choice from below)

### Code Nominal Voltage

<b>48</b>	480 VAC (Range: 24 - 530 VAC)
<b>60</b>	600 VAC (Range: 24 - 660 VAC)

### Code Input Control Signal

<b>1</b>	6 - 32 VDC
<b>2</b>	20 - 260 VAC/DC

### Code Alarm Outputs (Note: Alarms only available on ≥ 50 Amp Models)

<b>0</b>	None
<b>1</b>	Solid State Relay switch (normally open)
<b>2*</b>	Solid State Relay switch (normally closed)
<b>3*</b>	Digital Logic PNP Output (normally open)
<b>4*</b>	Digital Logic PNP Output (normally closed)

<sup>2</sup>External 24 VDC Power Supply is Required to Power the Alarms

### Code Fan (120 Amp Version Only), Inches (mm)

<b>0</b>	No Fan (select for all models < 120 Amp)
<b>1</b>	**Fan (230 VAC Power Supply Requirement)
<b>2</b>	**Fan (120 VAC Power Supply Requirement)

**CS1 - 050 48- 1 1 0 Typical Model Number**

**Notes:**

- <sup>1</sup> Available only on models ≥ 50 Amps
- <sup>2</sup> Some models may accept 24 VDC or 24 VAC. See optional Alarm Wiring details in manual.
- \* Available only for models with 6-32 VDC input control signal
- \*\* Fan requires customer supplied voltage.

The following Chromalox Temperature Controllers offer a suitable 24VDC power supply for the alarm option:

- 40 Series: 6040 / 8040 / 4040
- 50 Series: 6050 / 4050
- 60 Series: 6060
- 80 Series: 4080 / 4081 / 4082

**Limited Warranty:**

Please refer to the Chromalox limited warranty applicable to this product at <http://www.chromalox.com/customer-service/policies/termsosale.aspx>.

**Chromalox, Inc.**  
**1347 Heil Quaker Boulevard**  
**Lavergne, TN 37086**  
**(615) 793-3900**  
**www.chromalox.com**