

Installation & Operation Manual

# MOS Series Hot Oil System



PQ448  
161-123417-032  
May 2023

# MOS Series Hot Oil System

## Installation Instructions

### General Information

The Chromalox Heat Transfer Unit is a thoroughly engineered, pretested package, designed to give years of service, virtually maintenance free if properly installed. The MOS series can operate at 500°F (315°C), 600°F (315°C) or 650°F (343°C) at atmospheric pressure (depending upon heat transfer fluid properties and unit configuration) with features that comply with the National Electrical Code.

Common to all models: electronic process controller, air-cooled mechanical seal, chamber insulation, discharge pressure gauge, steel heater sheath, cast iron, centrifugal pump; power requirements 240 to 600 volts, 3 phase, 60 cycles, 50 thru 500kW.

### ⚠ WARNING

**In hazardous areas, pipe surfaces could achieve temperatures high enough to cause auto-ignition of the hazardous material present. Consult Article 500 of the National Electrical Code for further information on the maximum allowable temperature for a specific application.**

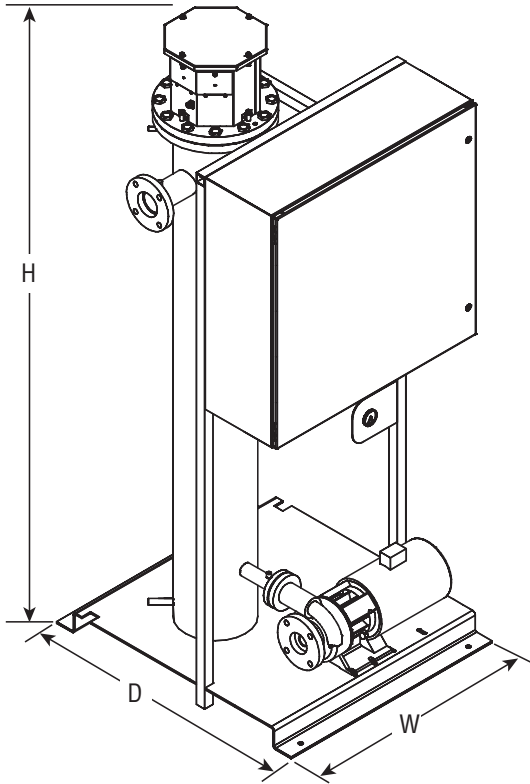

MOS 50-150 kW Unit (Front View)

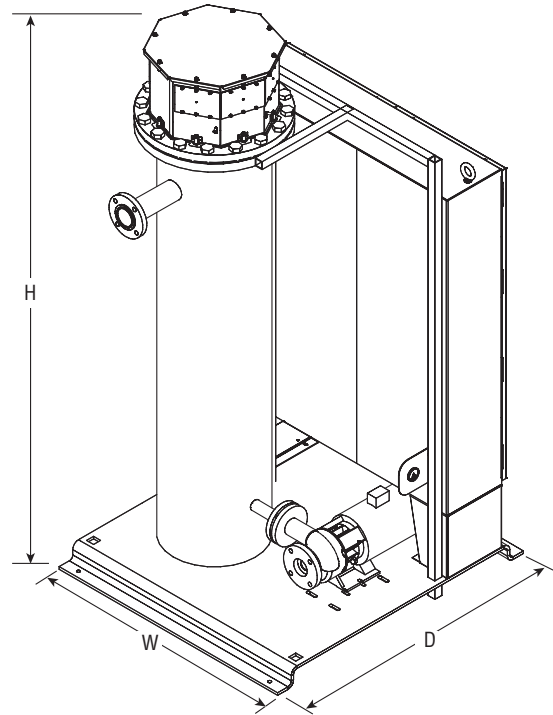

MOS 175-500 kW Unit (Rear View)

### Unit Proportions

Unit Size	Dry Weight (Lbs.)	Width (In.)	Depth (In.)	Height <sup>1</sup> (In.)	Flow Rate <sup>2</sup> GPM	Pressure <sup>2</sup> TDH (Ft.)	Motor HP	Inlet/Outlet Connection ANSI	System Capacity (Gal.)
50 & 75 kW	900	36	42	96	80	130	5	2", 150#	24
100-150 kW	1400	36	42	96	120	130	7.5	3", 150#	35
175-300 kW	2600	48	54	96	200	130	10	3", 150#	65
350-500 kW	3500	48	54	96	200 <sup>3</sup>	130	10 <sup>3</sup>	3", 150# <sup>3</sup>	85

<sup>1</sup> 650°F Option will add 8" to overall height.

<sup>2</sup> Refer to pump graph for full operating range

<sup>3</sup> Option for 300 GPM 20HP pump with 4", 150# inlet/outlet

## Fluid Compatibility

### **⚠ CAUTION**

***This system is NOT for use with water, ethylene glycol and water mixture or some of the synthetic heat transfer fluids.***

### **⚠ CAUTION**

***To avoid possible damage to the heaters do not energize the heater unless the system is filled with fluid.***

Read manufacturer's technical bulletins and instructions carefully. Some heat transfer fluids may ignite or burn spontaneously if not properly used.

If you are not sure you are using an accepted heat transfer fluid, check with fluid manufacturer.

**DO NOT** mix heat transfer fluids unless authorized and approved by the fluid manufacturer. All heat transfer fluids are not compatible with each other, whether made by the same manufacturer or a different manufacturer. If you plan to switch fluids, check with the fluid manufacturer to determine the following.

- A. Is the new fluid compatible with the old?
- B. What is the recommended cleaning method to remove the old fluid, its sludge, or any deposits remaining in the system?
- C. Does the fluid manufacturer have a reclaiming service for used fluid? Do they have recommended procedure for disposal of used or old fluid?

---

## Unit Installation

**Note:** When installing system, allow sufficient room to remove heating bundle.

### Hydraulics

**Note:** The MOS systems should be mounted so the control box does not fall in direct sunlight.

The bed plate should be mounted on a level, solid foundation and bolted down.

1. Allow at least 1 foot or more around unit for proper maintenance,
2. Unit is designed for 104°F (40°C) maximum operating environment.
3. Unit will be operating at elevated temperatures. Proper care must be provided to ensure personnel safety.

---

## Piping Installation

1. The pipe size should be the same as the system piping connections. All piping must be supported so the pump is not carrying any of the pipe weight. If these instructions are not followed, distortion in the pump may cause unnecessary wear and faulty operation.
2. The piping of the entire system should be arranged to minimize pockets where air may be trapped. Manual air vents or bleeder valves should be provided in the system where air pockets may occur, or where the flow of fluid may drop.
3. Piping should be properly supported so pump can be removed without changing the position of the piping. If piping moves when the pump is removed, pump malfunction is probably due to stresses and twisting caused by the piping. These stresses will multiply where the system is hot due to thermal expansion.
4. If there is a high differential pressure between the inlet and outlet of the heat transfer system at operating temperature, this is probably due to a piping restriction. A continuing high differential pressure can cause excessive wear on the pump and pump stuffing box packing or mechanical seal and will eventually cause premature failure of the pump. The major causes of restrictions are:

- a. Inlet and outlet pipes smaller than provided on the system.
- b. Piping many processes in series with one another. To reduce the pressure drop of the system, equipment should be re-piped in balanced parallel flow.

**DO** provide for expansion and contraction of process piping and connections to the system. Piping strains can cause pump and motor misalignment, excessive wear on pump body, bearings and stuffing box packing or mechanical seal and will eventually cause failure of the pump and system.

**DO** provide sufficient cross sectional area in the process piping connections equivalent to the system pipes. In order to prevent undue pressure drop, maximum velocity in all piping should be less than 10 feet per second.

**DO** check all vent tubes, purge valves, and bypass relief valves at least once a month. All heat transfer oils oxidize in the presence of air and sludge can block critical piping. Blocked vent tubes may cause excessive system pressures and/or an explosion.

**DO** retighten all bolted connections and joints at operating temperature. Joints will expand and leak as they get hot. Check all threaded connections on controls, gauges, etc. for leaks.

**DO** vent all systems operating at atmospheric pressure properly. Vents must be rigid metal piping terminating outside the building or into a suitable container. The vent line should never be made of plastic, rubber or other low temperature material and should match the vent port size on the expansion tank.

**DO NOT** use process piping connections smaller than the pipes used in the system.

**DO NOT** use Magnesium bed or porous insulations which can absorb oil. When oil soaked, these insulations may ignite spontaneously and burn at temperatures as low as 400°F (204°C).

**DO NOT** permit leaks of any heat transfer fluid to continue unattended. Periodic inspection of piping and insulation is essential.

**DO NOT** insulate expansion tank lines or the expansion tank. These components must be kept cool and below 130°F (54°C) for most heat transfer oils.

**DO NOT** insulate flanges, valves or other connections which may leak without being observed.

**DO NOT** use screwed pipe connections on any piping over 1 inch diameter. Use flanges for connections with spiral wound or Grafoil® gaskets.

**DO NOT** use Teflon tape or pipe seal on threaded connections on hot oil systems. Use Copalite® or SilverSeal® or other high temperature sealants compatible with heat transfer oils.

### **⚠ WARNING**

***Oil saturated insulation on piping may ignite spontaneously at elevated temperatures. Repair leaks and replace oil soaked insulation immediately!!***

---

## Expansion Tank Installation

Mount the expansion tank so it is the highest point in the system and if possible at least 15 feet (5 m) above the height of the pump. Connect the fluid level sight glass to the expansion tank. To safeguard employees and equipment, run the vent line either out of the building or down into a 55 gallon drum. The vent line piping should match the port size on the expansion tank.

### **⚠ CAUTION**

***To avoid possible rupture of expansion tank due to pressure, vent line should be checked on a regular basis to be sure it is always open to the atmosphere. Failure to do so may result in rupture of the expansion tank or other parts of the system causing injury or hazard of fire.***

**Note:** If the expansion tank cannot be mounted above the highest point in the system, or if the system is going to operate above the boiling temperature of the heat transfer fluid, the expansion tank will have to be pressurized with air or nitrogen. This eliminates the possibility of heat transfer fluid flashing into vapor in the heater, at the point of high velocity in the system,

### **⚠ WARNING**

***If expansion tank is to be pressurized, then it must be equipped with safety relief valve(s). If this pressure exceeds 15 PSIG, then the heat transfer system and expansion tank should be ASME coded.***

**DO NOT** mount expansion tank directly on top of system ***unless absolutely necessary***. If mounted on system, provisions must be made for cooling of the expansion tank line. Maximum safe operating temperatures are reduced when expansion tank is mounted on system unless positive suction pressure of 2 to 3 psig (0.14-0.21 bar) is maintained on pump.

---

## Pump Motor

The pump/motor is a close-coupled centrifugal pump rated for 650°F (343°C). Pump and motor mounts should be checked and tightened if loosened during shipment.

**DO** provide for expansion and contraction of process piping and connections to the system. Piping strains can cause pump and motor misalignment, excessive wear on pump body, bearings and stuffing box packing

or mechanical seal and will eventually cause failure of the pump and system.

Piping should be properly supported so pump can be removed without changing the position of the piping. If piping moves when the pump is removed, pump malfunction is probably due to stresses and twisting caused by the piping. These stresses will multiply when the system is hot due to thermal expansion.

Refer to graphs for pump performance curves.

50 & 75 kW Unit (5 hp)

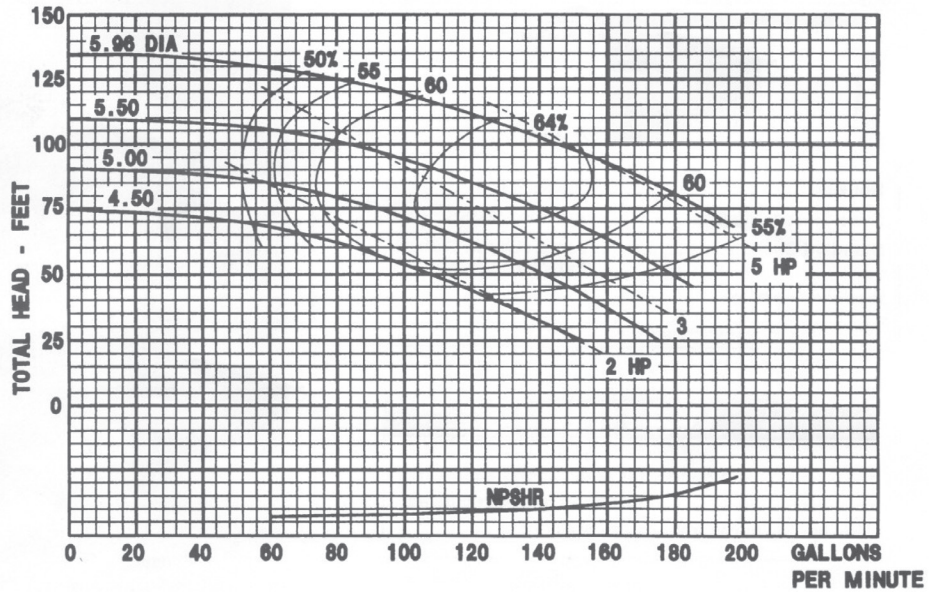

- \* Horsepower requirement based on 0.85 specific gravity
- \* Maximum operating temperature is 650°F. Maximum working pressure is 150 psi.

100 - 150 kW Unit (7.5 hp)  
175 - 500 kW Unit (10 hp)

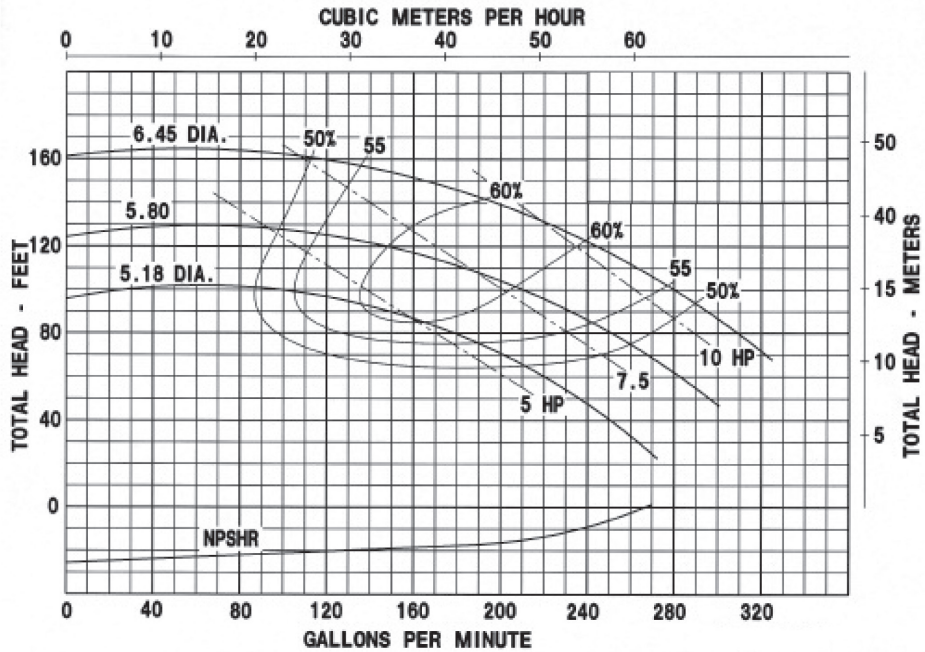

- \* Horsepower requirement based on 0.85 specific gravity
- \* Maximum operating temperature is 650°F. Maximum working pressure is 150 psi.

### 350 - 500 kW Unit (20 hp, optional)

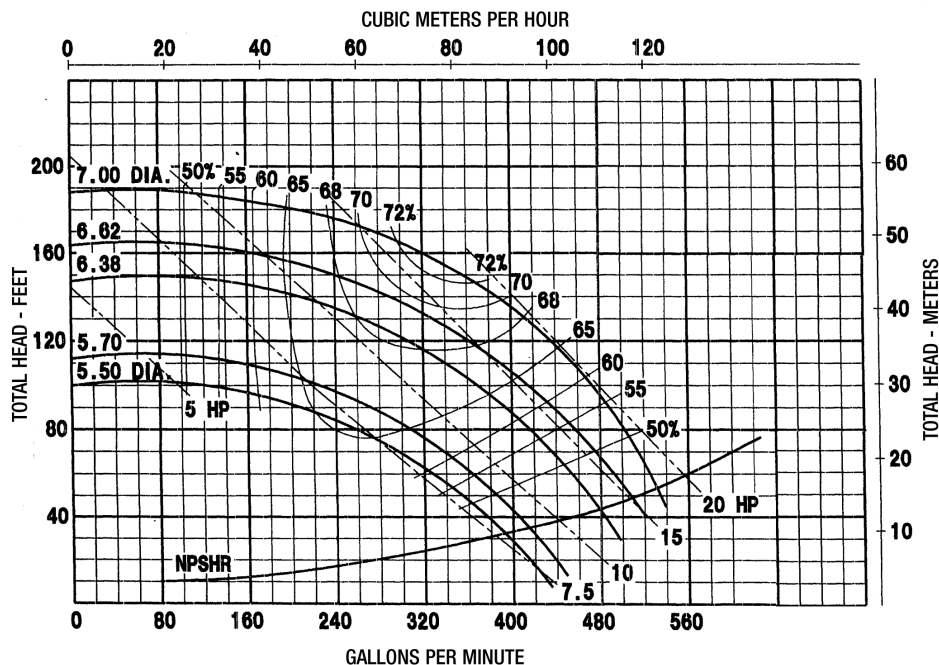

\* Horsepower requirement based on 0.85 specific gravity

\* Maximum operating temperature is 650°F. Maximum working pressure is 150 psi.

## Electrical Wiring

### ⚠ WARNING

**HAZARD OF ELECTRIC SHOCK. The heat transfer system must be grounded using grounding means provided in control box and employing wiring in accordance with National Electrical Code.**

1. Electric wiring to heater must be installed in accordance with the National Electrical Code, International Electrical Code and/or with local codes by a qualified person.
2. Electrical wiring to heater should be contained in rigid conduit or sealed in flexible conduit to keep corrosive vapors and liquids out. If high humidity is encountered, the conduit should slope away from the heater.
3. If flexible cord is employed, a watertight connector should be used for entry of the cord. Outdoor applications require liquid-tight conduit and connectors.
4. The current carrying capacity of the power supply leads should exceed the heater amperage by at least 25%. Be sure to consider the ambient operating temperature and apply the appropriate correction factor to the ampacity rating of the wire. Heaters with the same voltage and wattage may be connected in series for operation at a higher voltage.
5. The unit is completely wired. The only wiring necessary is to terminals L1, L2, and L3 in the control panel and the ground lug in the control panel.

### ⚠ WARNING

**HAZARD OF ELECTRIC SHOCK. Disconnect all power before servicing the heat transfer system.**

6. Jog the motor by pushing the push button marked START, located on the front of the panel. This test is to check pump rotation and the unit should be turned off immediately upon learning the direction of rotation.
7. The pump rotation should be as indicated by arrows on motor. If direction of rotation is wrong, reverse the input leads (L1 and L3) at the master circuit breaker. Momentarily start the pump to check rotation.
8. All electrical connections should be checked and tightened if necessary. They may loosen during transit.

### ⚠ CAUTION

**A minimum 257°F (125°C) insulated wiring should be used.**

**Note:** The control panel wiring diagram is typically included inside the control panel enclosure. If missing, a copy can be obtained by contacting your local Chromalox representative.

## Filling System

### **⚠ CAUTION**

**To avoid possible damage to the heaters, DO NOT energize the heater until the system is filled with fluid.**

### **⚠ WARNING**

**Avoid having the heat-transfer fluid spilled or leaked into the pipeline insulation as it has been found that spontaneous ignition of this fluid may result at elevated temperatures.**

### To Fill Using Expansion Tank

The expansion tank should be the highest point in the system. Simply fill the fluid in the expansion tank, while monitoring the air-bleed valves for complete fill. After filling by gravity, run pump and re-monitor air-bleed valves for any remaining air pockets.

### To Fill Using Pump

1. On systems equipped with a float switch on the expansion tank it will be necessary to bypass this switch until the system is filled in order to operate the pump. After system is filled remove bypass jumper to obtain protection of float switch. This switch will shut the system down in the event of a low liquid level or loss of heat transfer liquid thus preventing damage to system.
2. Close the system inlet gate valve and open the outlet and fill line (option) gate valves and heater bleed valve on all heaters. Prime the pump by pouring approximately 1 pint to 1 quart (1 L) of fluid through any inlet valve located above pump.
3. The system is then filled directly from the 55 gallon (208 L) drum(s) by connecting a hose to fill line and inserting it into the drum.
4. Next energize the pump to pull the fluid into the complete system and up into the expansion tank. When the fluid reaches the heater bleed valve, it should then be closed, and accordingly the bleeds on the customer's process closed when the fluid reaches them. The fill line remains open until the expansion tank sight glass indicates being 1/3 full. After the system is filled, shut down the pump and close the fill valve. Open system inlet valve.
5. Turn master circuit breaker off. Bleed air from all lines (including one located above pump) and re-close all bleed valves.
6. The temperature limiting device located inside the control panel should be checked to insure manual reset buttons are in the closed position. They should be set approximately 50°F (28°C) higher than the process control during normal operation.

7. Close control box door and turn circuit breaker on. Start pump – do not be alarmed if the pump is noisy during the initial start-up operation since it is due to air in the system.
8. Bleed out all air by opening bleeder valves. The pump should become quiet.

### **⚠ CAUTION**

**During the initial start-up operation, the liquid level in the expansion tank must be checked continually. This level should not exceed the three-quarter mark on the glass nor drop below the one-quarter mark. Note: If abnormal expansion of fluid is detected, this is probably due to a pocket of air or steam still present in the system. Check all bleed valves for air or steam and bleed if necessary. If problem continues, de-energize pump and bleed again.**

9. Set indicating controller at 220°F (105°C).
10. To energize the heater, turn the ON-OFF selector switch to the ON position after starting the pump if option chosen. The heater is interlocked with the pump motor starter so that, in the event of motor failure, the heating elements will shut off automatically.
11. Run the system until 220°F (105°C) is reached. Periodically open the bleeder valves to remove air from the system. At 220°F (105°C), any moisture trapped in the system will flash into steam as it goes through the heater and can be bled out through the bleeder valves.
12. Excessive moisture and air in the system will cause the heat transfer liquid to back up into the expansion tank, thus evacuating the heating chamber or chambers. If this happens, shut the system down, bleed off the steam and air and allow liquid to return to the heating chamber. Drain the system and recharge with new moisture-free heat transfer liquid. If pump continues to be noisy and cavitates or if abnormal expansion persists there is excessive moisture in the fluid.
13. After the system has been completely charged and free of air and steam pockets, set process controller at the desired temperature.

## Operation

### ⚠ CAUTION

**Process temperature should never exceed maximum system rating.**

For complete process controller instructions, please refer to Chromalox manual PK510.

If needed, factory settings for process controller can be referenced per table below:

Unit	Drawing Number
600°F, Contactor	223-123625-213
600°F, SCR Trim	223-123625-215
650°F, Contactor	223-123625-214
650°F, SCR Trim	223-123625-216

Element overtemperature control is pre-set from the factory at 500°F (260°C). This should be adjusted to a range of 50-100°F (28-56°C) above the operating set-point. For complete overtemperature controller instructions, please refer to Chromalox manual PDS LIMIT.

### ⚠ CAUTION

**Chromalox MOS unit is a component to a customer integrated process. Ensure adequate safety devices have been installed and function properly. Ensure proper review of Control Panel Information Package for proper installation and use.**

## Optional Accessories

Some MOS units are provided with optional equipment that require additional installation concerns.

### Strainer, Inlet/Outlet Valves and Dedicated Fill Connections

Ordering (2) or more of these options will require on-site installation to avoid shipment damage. The order of assembly, starting at pump inlet should be: strainer, fill connection, then gate valve. A bolting kit, with gaskets is provided for simple installation. Please note that during operation, the strainer should be checked as part of a regular maintenance program.

All added-on equipment must be adequately supported to avoid damage to pump.

## Purge Connections

Nitrogen purge connections are provided for a hazardous area. Ensure nitrogen system is operational and installed correctly prior to operation. Incoming power wiring must also be installed in accordance with NEC requirements for hazardous area.

## Digital Overtemperature Control

The overtemperature controller is pre-set at the factory to 500°F (260°C). The controller should be set for 50-100°F (28-56°C) higher than operating temperature. Please refer to Chromalox manual PK508 for complete operation.

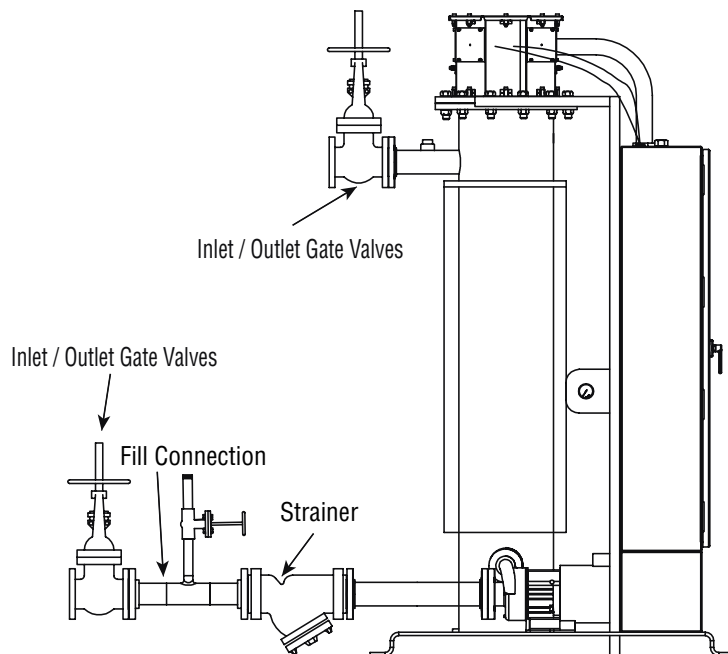

**Note:** All piping add-on accessories must be adequately supported to avoid damage to pump.

**Figure 2** Optional Piping Accessory Assembly

## STANDARD HEAT TRANSFER SYSTEM TROUBLE SHOOTING CHART

	Problem	Cause	Corrective Action
A	Power light off	Main power feed off	Turn on main power
		Circuit breaker off	Turn on circuit breaker
		Control transformer Primary fuse blown Secondary fuse blown Transformer bad	Replace fuse Replace fuse Check and/or replace
		Pilot light blown	Replace bulb
B	Power light on, pump will not start	Float switch open	Add oil to system, If no float switch, jumper terminals 4 & 5
		Motor overloads tripped	Reset overloads, check running current
C	Power light on, pump light on, motor not running	Motor starter bad	Check motor starter coil
		Motor fuse blown	Replace fuse, check motor overloads
D	Power light on, pump light on, motor running, pump not running	Motor burned out	Replace motor, check motor for overload
		Broken coupling	Check and replace coupling
E	Power light on, pump light on, motor running, pump running heat will not come on	Pump jammed by slag or foreign object	Turn off system and rotate pump by hand if jammed, disassemble and clean pump. Check and clean strainer.
		Heat on-off switch in off position	Turn switch to on
F	Insufficient heat	Process control ITC-1 set too low	Set process control to desired temperature
		No oil flow	See items: pump noisy, see L; insufficient suction pressure, seal; high discharge pressure, see J
		Process piping too small or restricted	Check process piping, check heat transfer area of platen, etc.
		Heater fuses blown	Check and replace fuses
G	System leaks when filling	Heater elements burned out	Check continuity and resistance of elements
		Rough handling during shipment	Check piping and flange alignment retighten and torque all bolts to specifications
H	System leaks at temperature and after cool down	Expansion and contraction due to temperature has loosened connections	Check all flange bolts and connections retighten and torque to manufacturer's specifications
		Wrong gasket materials	Replace gaskets as necessary, use spiral wound or Grafoil® gaskets
I	Insufficient suction pressure (0 or vacuum), pump noisy, gauges vibrating, discharge pressure low (below 20 psig)	System temperature too high for oil causing vapor lock	See fluid manufacturer's data for maximum oil temperature
		Vapors lock due to steam or air in oil	Bleed air & steam from system, change oil if problem continues
		Net positive suction pressure too low	Raise expansion tank to increase suction head, static head should be 4-5 psig.
		Strainer plugged	Remove and clean strainer
		Valve closed	Check all valves
J	High discharge pressure over 40 psig, pressure gauges fluctuating rapidly, pump noisy, expansion tank normal, system operating on bypass relief valve	System piping blocked or restricted	Check all valves, check strainer
		Process piping blocked or restricted	Check process piping sizing, check for closed valves or improperly installed automatic valves, check all bleed valves for air or steam
K	Expansion tank overflows or "burps" (over 220°F)	Steam or water in oil	Bleed system, change oil
		Expansion tank too low	Expansion tank should be mounted 15 ft. above system
		Expansion tank line too short	Lengthen expansion tank line to cool oil and provide cold oil seal
		Tank too small for system	Check volume on process piping
L	Pump noisy and/or cavitation	Air or steam in system	Bleed system periodically until all air or stem is removed Insufficient bleed valves in process piping to remove trapped air
		Contaminated oil	Change oil
		Pump damaged by overtightened packing gland	Replace pump
		Insufficient suction pressure	Suction pressure should be 4-5 psig

## Start-Up Supervision

Factory trained personnel are highly recommended for those customers who are unfamiliar with the initial start-up.

Contact your local Chromalox sales office or call the Chromalox Service Center: 1-800-443-2640.

## Maintenance

Factory trained personnel are recommended for those unfamiliar with proper system maintenance.

Contact your local Chromalox sales office or call the Chromalox Service Center: 1-800-443-2640.

## Maximum Temperatures

**DO NOT** attempt to operate any heat transfer system or heat transfer oil at temperatures higher than those recommended by the manufacturer.

Chromalox heat transfer systems are designed for a particular maximum temperature. If you do not know this design temperature, check with the Chromalox factory or consult the individual instruction sheet for that system. Exceeding the designed temperature of the heat transfer system will void the warranty.

Exceeding the temperature limits of the heat transfer fluid will cause its thermal breakdown or degradation.

This will result in the formation of sludge in the system and carbon on the heating elements and eventually cause pump and heater failure. If you do not know this maximum temperature, check with the fluid manufacturer.

### **⚠ WARNING**

***In hazardous or explosive areas, the pipe surfaces of oil type heat transfer systems could achieve temperatures higher than allowed for Class I, Group D, Division I.***

## Renewal Parts Identification

Gasket	Size (In.)	Rating
304639-007	2	150#
304639-009	3	150#

Miscellaneous	Description
118661-037	Discharge Pressure Gauge
118661-038	Suction Pressure Gauge
122571-076	Process Thermocouple
305910-005	Overtemperature Thermocouple

For replacement heater bundle or spare parts not listed in this instruction sheet, please contact Chromalox Customer Service Center. 1-800-443-2646

Pump seals in unit are not included in the product warranty. Pump seals can be purchased as a separate item.

### Limited Warranty:

Please refer to the Chromalox limited warranty applicable to this product at <http://www.chromalox.com/customer-service/policies/termsofsale.aspx>.

**Chromalox, Inc.**  
**2150 N. Rulon White Blvd.**  
**Ogden, UT 84404**  
**(800) 368-2493**  
**www.chromalox.com**