Multi-point Digital Controller

3340/3380

***Communication
Instruction Manual***

- Modbus is a registered trademark of Schneider Electric.
- Company names and product names used in this manual are the trademarks or registered trademarks of the respective companies.

In order to achieve maximum performance and ensure proper operation of your new instrument, carefully read all the instructions in this manual. Please place this manual in a convenient location for easy reference.

SYMBOLS

WARNING : This mark indicates precautions that must be taken if there is danger of electric shock, fire, etc., which could result in loss of life or injury.

CAUTION : This mark indicates that if these precautions and operating procedures are not taken, damage to the instrument may result.



: This mark indicates that all precautions should be taken for safe usage.



: This mark indicates important information on installation, handling and operating procedures.



: This mark indicates supplemental information on installation, handling and operating procedures.



: This mark indicates where additional information may be located.



WARNING

- An external protection device must be installed if failure of this instrument could result in damage to the instrument, equipment or injury to personnel.
- All wiring must be completed before power is turned on to prevent electric shock, fire or damage to instrument and equipment.
- This instrument must be used in accordance with the specifications to prevent fire or damage to instrument and equipment.
- This instrument is not intended for use in locations subject to flammable or explosive gases.
- Do not touch high-voltage connections such as power supply terminals, etc. to avoid electric shock.
- Chromalox[®] Precision Heat and Control is not responsible if this instrument is repaired, modified or disassembled by other than factory-approved personnel. Malfunction can occur and warranty is void under these conditions.

CAUTION

- This is a Class A instrument. In a domestic environment, this instrument may cause radio interference, in which case the user may be required to take adequate measures.
- This instrument is protected from electric shock by reinforced insulation. Provide reinforced insulation between the wire for the input signal and the wires for instrument power supply, source of power and loads.
- Be sure to provide an appropriate surge control circuit respectively for the following:
 - If input/output or signal lines within the building are longer than 30 meters.
 - If input/output or signal lines leave the building, regardless the length.
- This instrument is designed for installation in an enclosed instrumentation panel. All high-voltage connections such as power supply terminals must be enclosed in the instrumentation panel to avoid electric shock by operating personnel.
- All precautions described in this manual should be taken to avoid damage to the instrument or equipment.
- All wiring must be in accordance with local codes and regulations.
- All wiring must be completed before power is turned on to prevent electric shock, instrument failure, or incorrect action.

The power must be turned off before repairing work for input break and output failure including replacement of sensor, contactor or SSR, and all wiring must be completed before power is turned on again.
- To prevent instrument damage or failure, protect the power line and the input/output lines from high currents with a protection device such as fuse, circuit breaker, etc.
- Prevent metal fragments or lead wire scraps from falling inside instrument case to avoid electric shock, fire or malfunction.
- Tighten each terminal screw to the specified torque found in the manual to avoid electric shock, fire or malfunction.
- For proper operation of this instrument, provide adequate ventilation for heat dispensation.
- Do not connect wires to unused terminals as this will interfere with proper operation of the instrument.
- Turn off the power supply before cleaning the instrument.
- Do not use a volatile solvent such as paint thinner to clean the instrument. Deformation or discoloration will occur. Use a soft, dry cloth to remove stains from the instrument.
- To avoid damage to instrument display, do not rub with an abrasive material or push front panel with a hard object.
- Do not connect modular connectors to telephone line.

NOTICE

- This manual assumes that the reader has a fundamental knowledge of the principles of electricity, process control, computer technology and communications.
- The figures, diagrams and numeric values used in this manual are only for purpose of illustration.
- Chromalox[®] Precision Heat and Control is not responsible for any damage or injury that is caused as a result of using this instrument, instrument failure or indirect damage.
- Periodic maintenance is required for safe and proper operation of this instrument. Some components have a limited service life, or characteristics that change over time.
- Every effort has been made to ensure accuracy of all information contained herein. Chromalox[®] Precision Heat and Control makes no warranty expressed or implied, with respect to the accuracy of the information. The information in this manual is subject to change without prior notice.
- No portion of this document may be reprinted, modified, copied, transmitted, digitized, stored, processed or retrieved through any mechanical, electronic, optical or other means without prior written approval from Chromalox[®] Precision Heat and Control.

CONTENTS

	Page
1. OUTLINE	1
2. SPECIFICATIONS	2
3. WIRING	4
4. SETTING	7
4.1 Transfer to Setup Setting Mode.....	7
4.2 Setting the Communication Parameters	8
4.3 Communication Requirements	12
5. MODBUS COMMUNICATION PROTOCOL	13
5.1 Message Format.....	13
5.2 Function Code	14
5.3 Communication Mode.....	14
5.4 Slave Responses.....	15
5.5 Calculating CRC-16	16
5.6 Message Format.....	18
5.6.1 Read holding registers [03H]	18
5.6.2 Preset single register [06H]	19
5.6.3 Diagnostics (loopback test) [08H]	20
5.6.4 Preset multiple registers [10H].....	21
5.7 Data Configuration.....	22
5.7.1 Data range.....	22
5.7.2 Data processing precautions	23
5.8 Communication Data List.....	24
5.9 Data Map	31
5.9.1 Reference to data map	31
5.9.2 Data map list.....	32
6. TROUBLESHOOTING	44

MEMO

1. OUTLINE

Multi-point Digital Controller 3340/3380 interfaces with the host computer via Modbus protocol. The three types of communication interfaces are available: RS-422A, RS-485 and RS-232C. For reference purposes, the Modbus protocol identifies the host computer as master, the 3340/3380 as slave.

■ RS-422A or RS-485

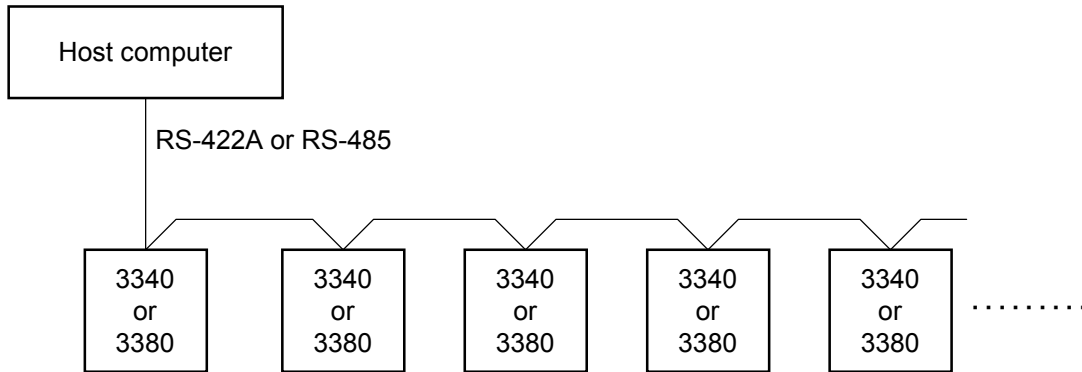

■ RS-232C

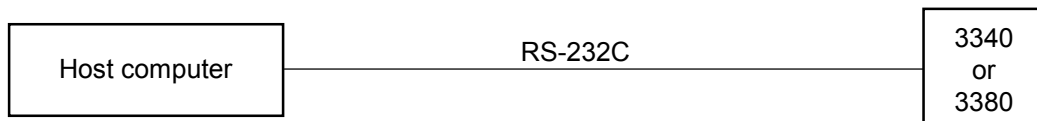

2. SPECIFICATIONS

Interface:	Based on RS-422A, EIA standard Based on RS-485, EIA standard Based on RS-232C, EIA standard (Specify when ordering)
Connection method:	4-wire system, half-duplex multi-drop connection (RS-422A) 2-wire system, half-duplex multi-drop connection (RS-485) 3-wire system, point-to-point connection (RS-232C)
Synchronous method:	Start/stop synchronous type
Communication speed:	2400 bps, 4800 bps, 9600 bps, 19200 bps
Data bit configuration:	Data bit: 8 (Byte data corresponding to binary data or bit.) Parity bit: Without, Odd or Even Stop bit: 1 or 2 (However, with the parity bit selected: 1 bit fixed)
Protocol:	Modbus
Signal transmission mode:	Remote Terminal Unit (RTU) mode
Function code:	03H (Read holding registers) 06H (Preset single register) 08H (Diagnostics: loopback test) 10H (Preset multiple registers)
Error check method:	CRC-16
Error code:	1: Function code error 2: When any address other than 0000H to 02EEH and 1388H to 14A0H are specified 3: When the specified number of data items in the query message exceeds the maximum number of data items available 4: Self-diagnostic error response
Termination resistor:	Externally connected (RS-485)
Maximum connections:	RS-422A, RS-485: 32 instruments maximum including a master RS-232C: 1 instrument

Signal logic:

RS-422A, RS-485

Signal voltage	Logic
$V(A) - V(B) \geq 2\text{ V}$	0 (SPACE)
$V(A) - V(B) \leq -2\text{ V}$	1 (MARK)

Voltage between V (A) and V (B) is the voltage of (A) terminal for the (B) terminal.

RS-232C

Signal voltage	Logic
+3 V or more	0 (SPACE)
-3 V or less	1 (MARK)

3. WIRING



WARNING

To prevent electric shock or instrument failure, do not turn on the power until all the wiring is completed.

■ Connection to the RS-422A port of the host computer (master)

● Communication terminal number and signal details

Terminal No.	Signal name	Symbol
44	Signal ground	SG
45	Send data	T (A)
46	Send data	T (B)
47	Receive data	R (A)
48	Receive data	R (B)

● Wiring method

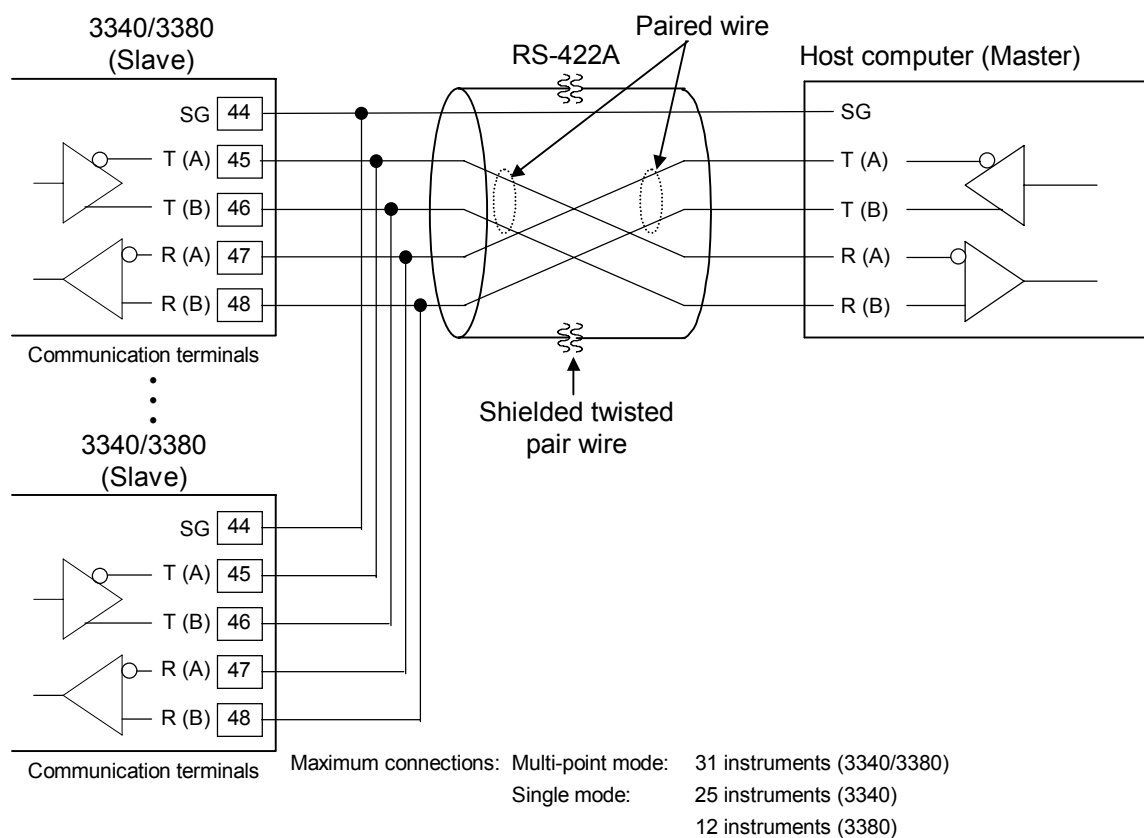

The cable is provided by the customer.

■ Connection to the RS-485 port of the host computer (master)

● Communication terminal number and signal details

Terminal No.	Signal name	Symbol
44	Signal ground	SG
45	Send data/Receive data	T/R (A)
46	Send data/Receive data	T/R (B)

● Wiring method

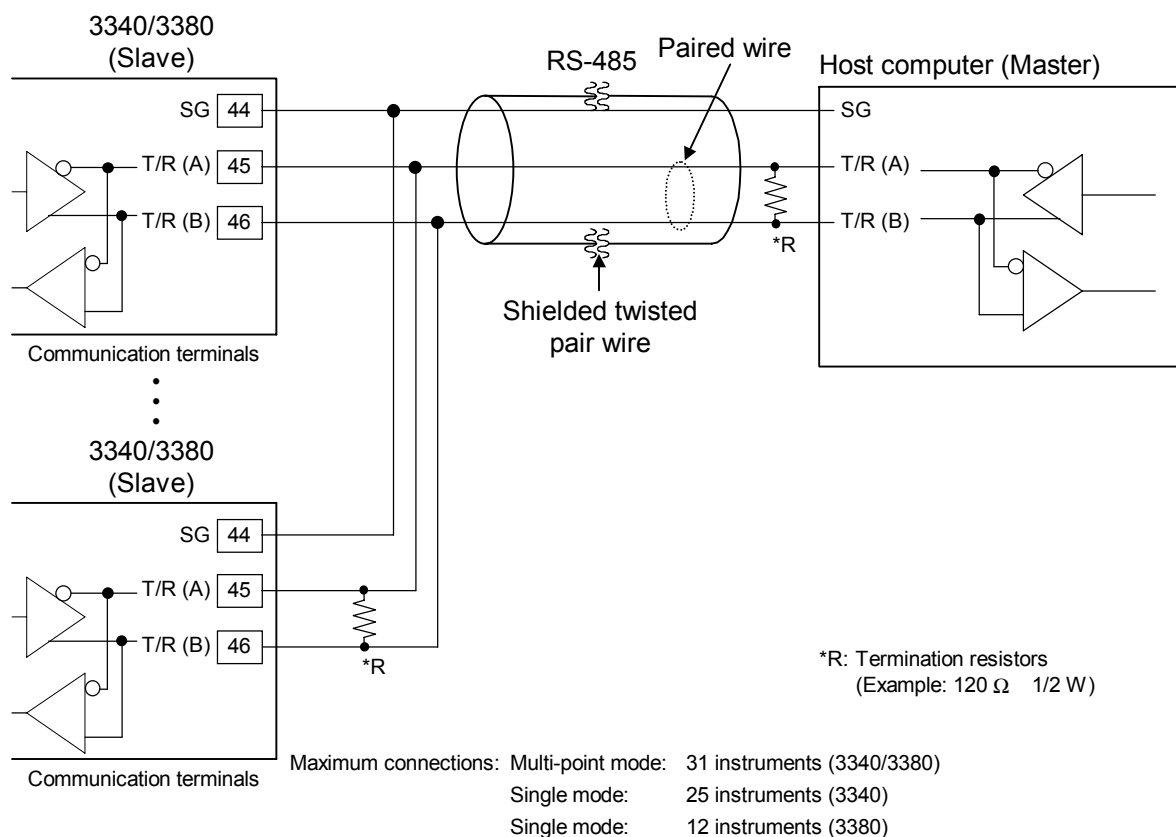

 The cable is provided by the customer.

■ **Connection to the RS-232C port of the host computer (master)**

● **Communication terminal number and signal details**

Terminal No.	Signal name	Symbol
44	Signal ground	SG (GND)
45	Send data	SD (TXD)
46	Receive data	RD (RXD)

● **Wiring method**

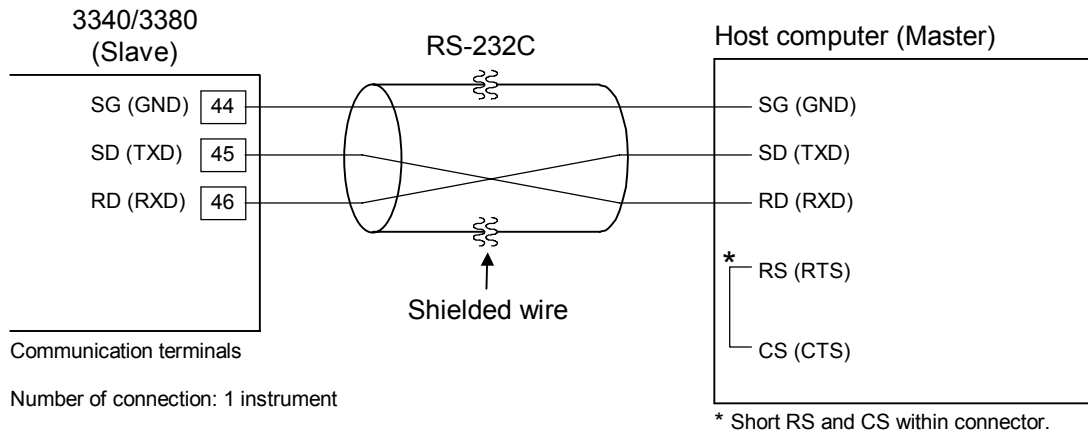

The cable is provided by the customer.

■ **Connection example (For the 3340/3380 multi-point mode)**

Connection with up to 31 3340/3380 (slaves) and one host computer (master)

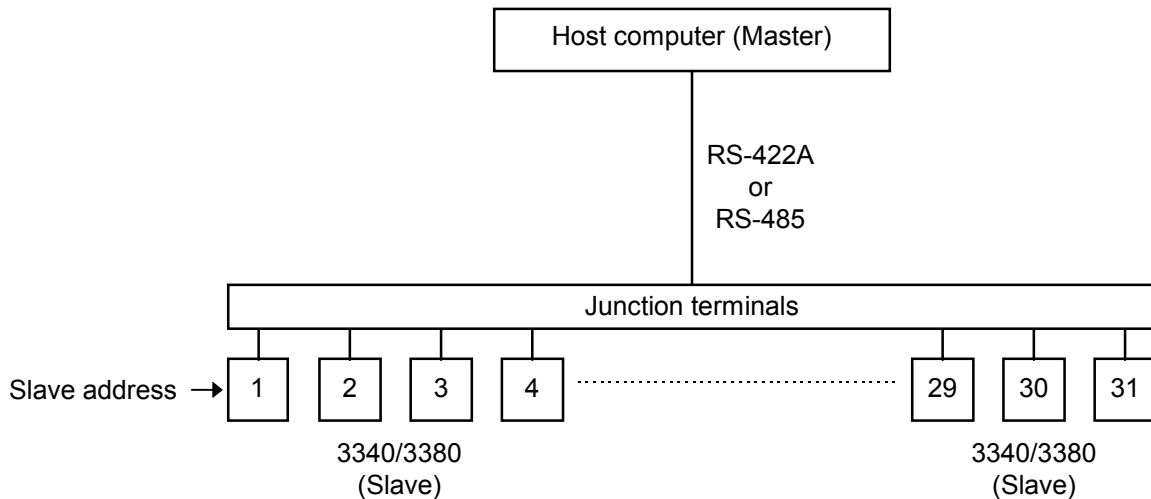

4. SETTING

To establish communication parameters between host computer (master) and 3340/3380 (slave), it is necessary to set the slave address, communication speed, data bit configuration and interval time on each 3340/3380 (slave) in the setup setting mode.

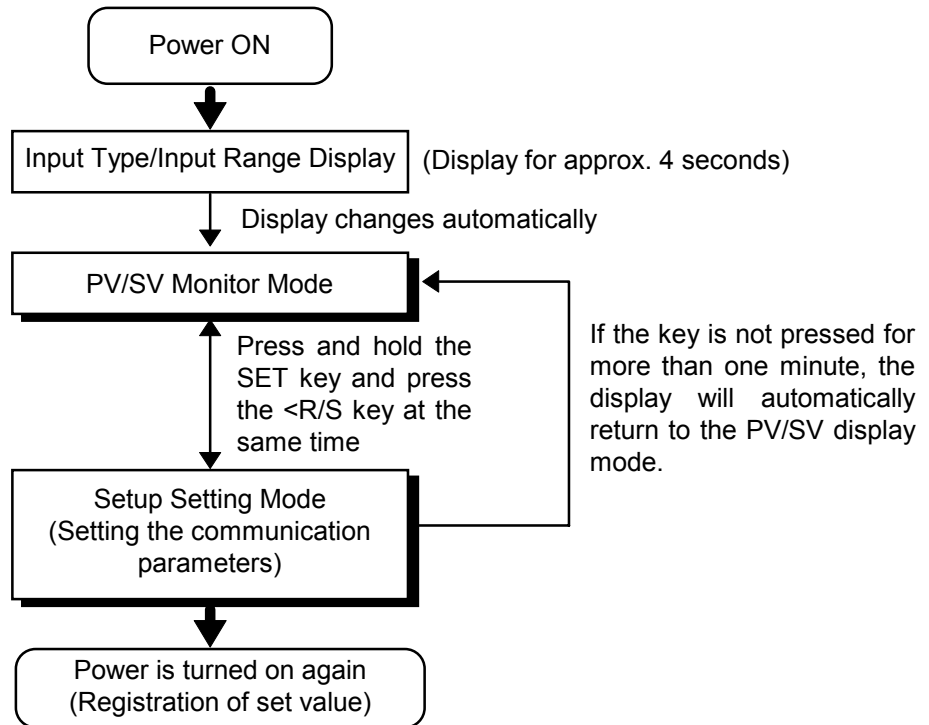

4.1 Transfer to Setup Setting Mode

To go the setup setting mode, you must be in PV/SV monitor mode. The first parameter to be displayed will be the autotuning, *ATU*. Press the SET key several times to change to the slave address "*Add.*"

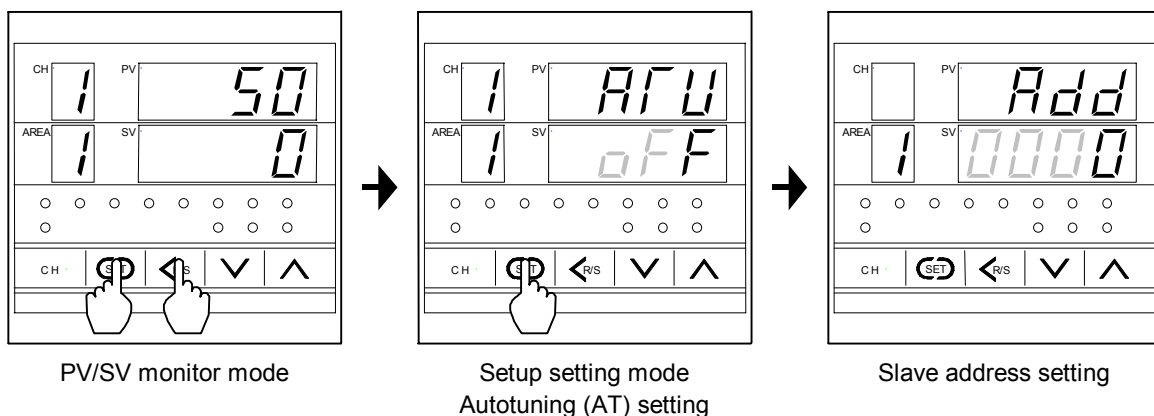

When let setup setting mode finish, press and hold the SET key and press the <R/S key at the same time. The display changes to the PV/SV monitor mode.

4.2 Setting the Communication Parameters

To select parameters in setup setting mode, press the SET key. The parameters are displayed and sequenced in the order of slave address, *Add*, communication speed, *bPS*, data bit configuration, *bIT* and interval time set value, *InT*.

■ Setting procedure

Setting procedure vary depending on the communication parameter.

- Slave address *Add*, interval time *InT*
Operate UP, DOWN and <R/S key, and input numerals.
- Communication speed *bPS*, data bit configuration *bIT*
Operate UP or DOWN key, and choose one among the displayed set value.

For 3340: Proportioning cycle time setting (heat control) or
Cool-side proportioning cycle time setting (heat/cool control)
For 3380: Proportioning cycle time setting

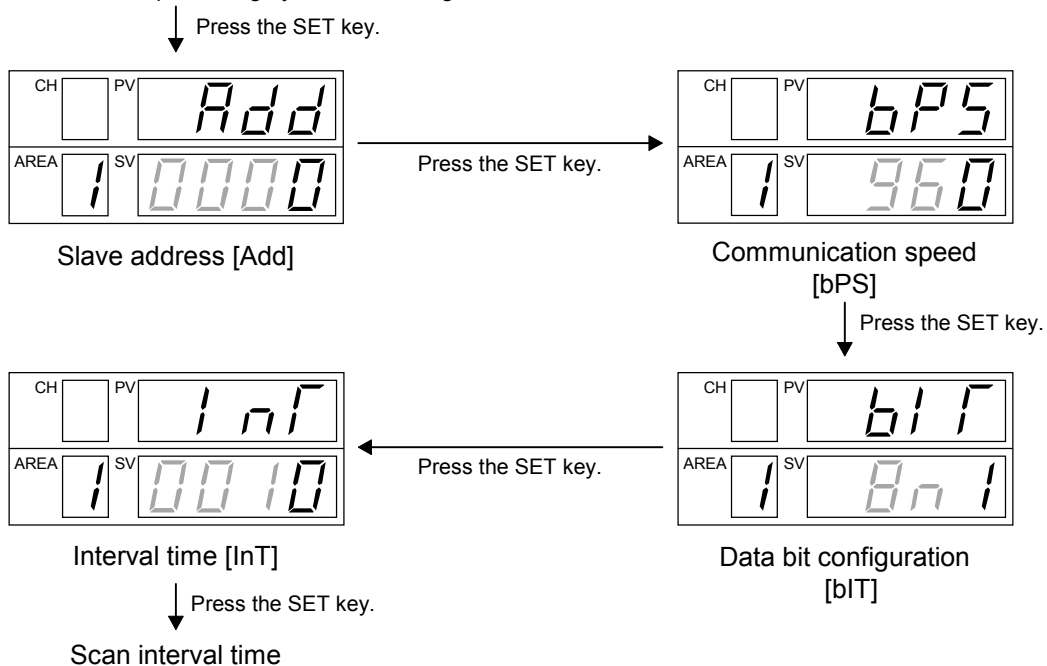

■ Registration of set value

After completing all communication parameter settings, turn on the power again, and register the set value which changed.

After the power is turned on again, communication is mode using the set value changed.



Not by turning the power on again, the set value can also be registered by changing to RUN from STOP.

■ Description of each parameters

Symbol	Name	Setting range	Description	Factory set value
<i>Add</i> (Add)	Slave address	0 to 99	Set it not to duplication in multi-drop connection. If the slave address is set to 0 in Modbus, two-way communication cannot be performed.	0
<i>bPS</i> (bPS)	Communication speed	240: 2400 bps 480: 4800 bps 960: 9600 bps 1920: 19200 bps	Set the same communication speed for both the 3340/3380 (slave) and the host computer (master).	960
<i>bit</i> (bIT)	Data bit configuration	See data bit configuration table	Set the same data bit configuration for both the 3340/3380 (slave) and the host computer (master).	8n1
<i>InT</i> (InT)	Interval time *	0 to 250 ms	The 3340's or 3380's interval time must match the specifications of the host computer.	10

Data bit configuration table

Set value	Data bit	Parity bit	Stop bit
<i>8n1</i> (8n1)	8	Without	1
<i>8n2</i> (8n2)	8	Without	2
<i>8E1</i> (8E1)	8	Even	1
<i>8o1</i> (8o1)	8	Odd	1

* The interval time for the 3340/3380 should be set to provide a time for host computer to finish sending all data including stop bit and to switch the line to receive data. If the interval time between the two is too short, the 3340/3380 may send data before the host computer is ready to receive it. In this case, communication transmission can not be conducted correctly. For a successful communication sequence to occur, the 3340's or 3380's interval time must match the specifications of the host computer.



No setting can be changed when "1: Lock" is selected by the lock level 1.



For the lock level 1, see the **Instruction Manual (0037-75425)**.

■ **Setting procedure example**

1. Go to the setup setting mode so that slave address, *Add*, is displayed. Present set value is displayed, and the least significant digit light brightly.

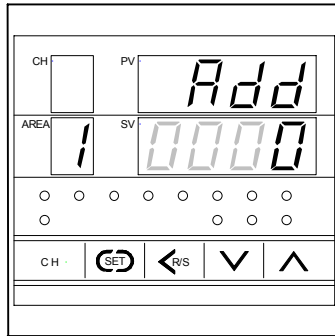

Slave address setting

2. Set the slave address. Press the UP key to enter 5 at the least significant digit.
Example: Setting the slave address to 15.

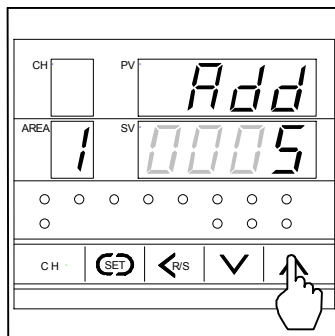

3. Press the <R/S key to brightly light the tens digit.

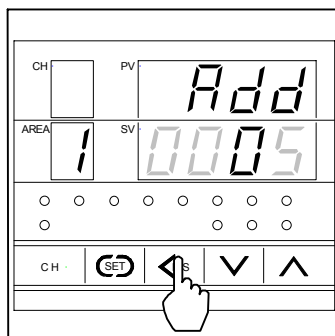

4. Press the UP key to enter 1 at the tens digit.

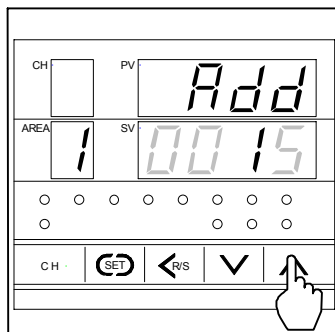

5. Press the SET key to set the value thus set. The display changes to the next communication parameter. If the SET key is not pressed within 1 minute, the present display returns to the PV/SV monitor mode and the value set here returns to that before the setting is changed.

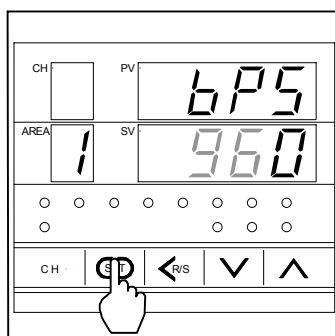

Communication speed setting

6. After completing all communication parameter settings, turn on the power again, and register the set value which changed. After the power is turned on again, communication is made using the set value changed.



Besides power on again, register of set value with RUN/ STOP transfer. In this case, have to change to STOP before setting communication parameter. Change to RUN after completing the communication parameter settings, the instrument performs the same operation as that at the time of power on again.

In addition, if the communication parameter is changed at RUN, communication is made using the set value changed if returned to RUN once set to STOP.



For the RUN/STOP transfer, see the **Instruction Manual (0037-75425)**.

4.3 Communication Requirements

■ Processing times during data send/receive

The 3340/3380 requires the following processing times during data send/receive.

Procedure details	Time
Read holding registers [03H] Response transmission time after the slave receives the query message	20 ms max.
Preset single register [06H] Response transmission time after the slave receives the query message	3 ms max.
Diagnostics (loopback test) [08H] Response transmission time after the slave receives the query message	3 ms max.
Preset multiple registers [10H] Response transmission time after the slave receives the query message	20 ms max.



Response send time is time at having set interval time in 0 ms.

■ RS-422A/RS-485 Fail-safe

A transmission error may occur with the transmission line disconnected, shorted or set to the high-impedance state. In order to prevent the above error, it is recommended that the fail-safe function be provided on the receiver side of the host computer. The fail-safe function can prevent a framing error from its occurrence by making the receiver output stable to the MARK (1) when the transmission line is in the high-impedance state.

5. MODBUS COMMUNICATION PROTOCOL

The master controls communication between master and slave. A typical message consists of a request (query message) sent from the master followed by an answer (response message) from the slave. When master begins data transmission, a set of data is sent to the slave in a fixed sequence. When it is received, the slave decodes it, takes the necessary action, and returns data to the master.

5.1 Message Format

The message consists of four parts: slave address, function code, data, and error check code which are always transmitted in the same sequence.

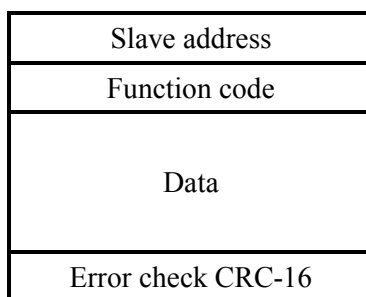

Message format

■ Slave address

The slave address is a number from 1 to 99 manually set at the front key panel of the controller.

☞ For details, see **4.2 Setting the Communication Parameters (P. 8)**.

Although all connected slaves receive the query message sent from the master, only the slave with the slave address coinciding with the query message will accept the message.

■ Function code

The function codes are the instructions set at the master and sent to the slave describing the action to be executed. The function codes are included when the slave responds to the master.

☞ For details, see **5.2 Function Code (P. 14)**.

■ Data

The data to execute the function specified by the function code is sent to the slave and corresponding data returned to the master from the slave.

☞ For details, see **5.6 Message Format (P. 18)**, **5.7 Data Configuration (P. 22)** and **5.8 Communication Data List (P. 24)**.

■ Error check

An error checking code (CRC-16: Cyclic Redundancy Check) is used to detect an error in the signal transmission.

☞ For details, see **5.5 Calculating CRC-16 (P. 16)**.

5.2 Function Code

Function code contents

Function code (Hexadecimal)	Function	Contents
03H	Read holding registers	Measured value (PV), alarm status, etc.
06H	Preset single register	Set value (SV), alarm set value, PID constants, PV bias, etc. (For each word)
08H	Diagnostics (loopback test)	Diagnostics (loopback test)
10H	Preset multiple registers	Set value (SV), alarm set value, PID constants, PV bias, etc.

Message length of each function (Unit: byte)

Function code (Hexadecimal)	Function	Query message		Response message	
		Min	Max	Min	Max
03H	Read holding registers	8	8	7	255
06H	Preset single register	8	8	8	8
08H	Diagnostics (loopback test)	8	8	8	8
10H	Preset multiple registers	11	255	8	8

5.3 Communication Mode

Signal transmission between the master and slaves is conducted in Remote Terminal Unit (RTU) mode.

RTU mode

Items	Contents
Data bit length	8 bit (Binary)
Start mark of message	Unused
End mark of message	Unused
Message length	See 5.2 Function Code
Data time interval	24 bits' time or less *
Error check	CRC-16 (Cyclic Redundancy Check)

* The data time intervals in one query message from the master must be 24 bits' time or less. If the data time interval exceeds 24 bits' time, the slave regards the transmission as ended and because the message format is incomplete, the slave does not respond.

5.4 Slave Responses

(1) Normal response

- In the response message of the Read Holding Registers, the slave returns the read out data and the number of data items with the same slave address and function code as the query message.
- In the response message of the Preset Single Resister, the slave returns the same message as the query message.
- In the response message of the Diagnostics (loopback test), the slave returns the same message as the query message.
- In the response message of the Preset Multiple Resister, the slave returns the slave address, the function code, starting number and number of holding registers in the multi-query message.

(2) Defective message response

- If the query message from the master is defective, except for transmission error, the slave returns the error response message without any action.

Slave address
Function code
Error code
Error check CRC-16

Error response message

- If the self-diagnostic function of the slave detects an error, the slave will return an error response message to all query messages.
- The function code of each error response message is obtained by adding 80H to the function code of the query message.

Error code	Contents
1	Function code error (Specifying nonexistent function code)
2	When any address other than 0000H to 02EEH and 1388H to 14A0H are specified. (However, no error returns for any address from 03E8H to 0563H. Therefore, do not access any of the above addresses.)
3	When the specified number of data items in the query message exceeds the maximum number of data items available
4	Self-diagnostic error response

(3) No response

The slave ignores the query message and does not respond when:

- The slave address in the query message does not coincide with any slave address settings.
- The CRC code of the master does not coincide with that of the slave.
- Transmission error such as overrun, framing, parity and etc., is found in the query message.
- Data time interval in the query message from the master exceeds 24 bits' time.

5.5 Calculating CRC-16

The Cyclic Redundancy Check (CRC) is a 2 byte (16-bit) error check code. After constructing the data message, not including start, stop, or parity bit, the master calculates a CRC code and appends this to the end of the message. The slave will calculate a CRC code from the received message, and compare it with the CRC code from the master. If they do not coincide, a communication error has occurred and the slave does not respond.

The CRC code is formed in the following sequence:

1. Load a 16-bit CRC register with FFFFH.
2. *Exclusive OR* (\oplus) the first byte (8 bits) of the message with the CRC register. Return the result to the CRC register.
3. Shift the CRC register 1 bit to the right.
4. If the carry flag is 1, *exclusive OR* the CRC register with A001 hexadecimal and return the result to the CRC register. If the carry flag is 0, repeat step 3.
5. Repeat step 3 and 4 until there have been 8 shifts.
6. *Exclusive OR* the next byte (8 bits) of the message with the CRC register.
7. Repeat step 3 through 6 for all bytes of the message (except the CRC).
8. The CRC register contains the 2 byte CRC error code. When they are appended to the message, the low-order byte is appended first, followed by the high-order byte.

■ The flow chart of CRC-16

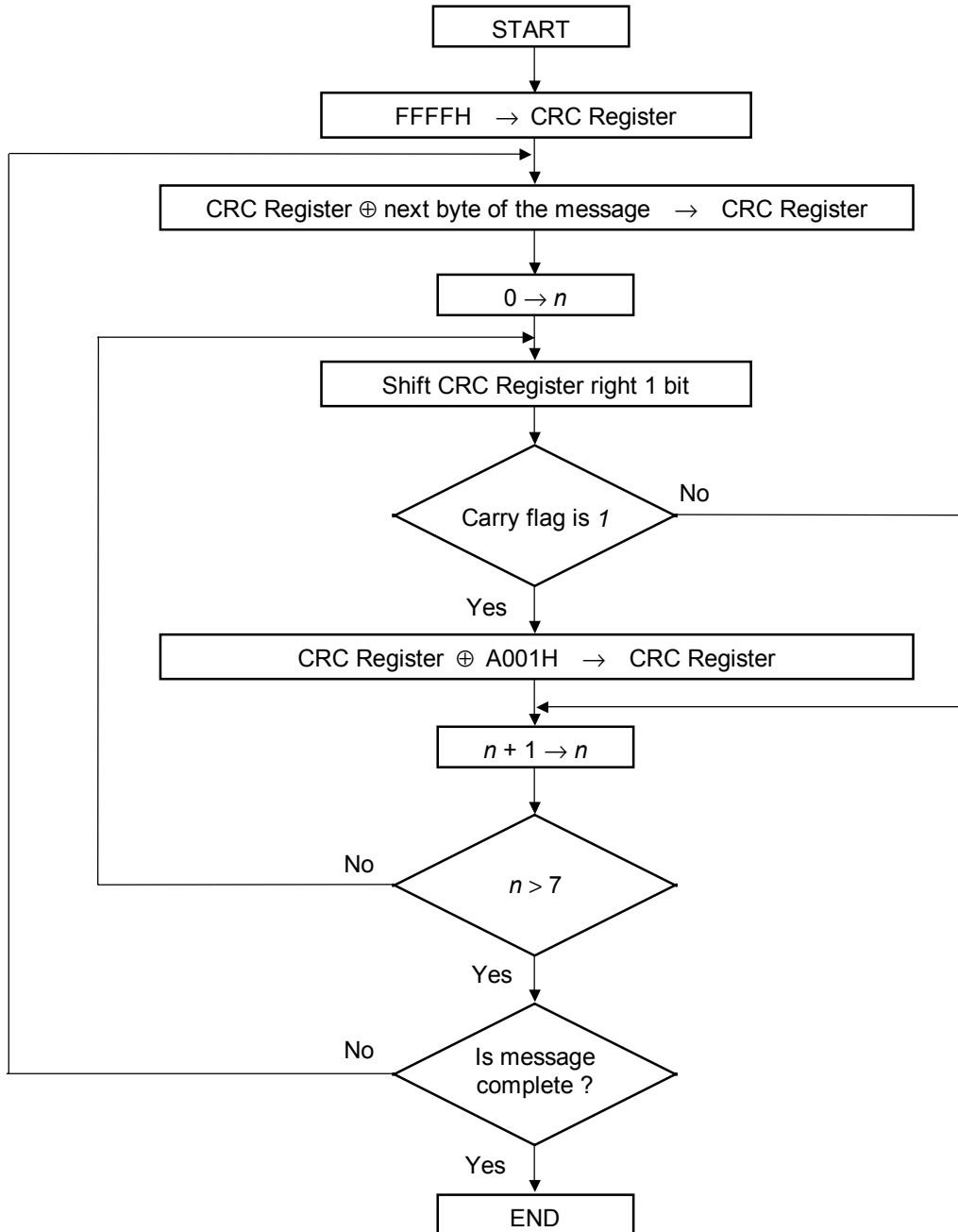

The \oplus symbol indicates an *exclusive OR* operation. The symbol for the number of data bits is n .

5.6 Message Format

5.6.1 Read holding registers [03H]

The query message specifies the starting register address and quantity of registers to be read. The contents of the holding registers are entered in the response message as data, divided into two parts: the high-order 8 bits and the low-order 8 bits, arranged in the order of the register numbers.

Example: The contents of the three holding registers from 0000H to 0002H are the read out from slave address 2.

Query message

Slave address		02H	
Function code		03H	
Starting number	High	00H	} First holding register address
	Low	00H	
Quantity	High	00H	} The setting must be between 1 (0001H) and 125 (007DH).
	Low	03H	
CRC-16	High	05H	
	Low	F8H	

Normal response message

Slave address		02H	
Function code		03H	
Number of data		06H	→ Number of holding registers × 2
First holding register contents	High	00H	
	Low	00H	
Next holding register contents	High	00H	
	Low	01H	
Next holding register contents	High	00H	
	Low	02H	
CRC-16	High	E5H	
	Low	84H	

Error response message

Slave address		02H
80H + Function code		83H
Error code		03H
CRC-16	High	F1H
	Low	31H

5.6.2 Preset single register [06H]

The query message specifies data to be written into the designated holding register. The write data is arranged in the query message with high-order 8 bits first and low-order 8 bits next. Only R/W holding registers can be specified.

Example: Data is written into the holding register 00C8H of slave address 1.

Query message

Slave address		01H	
Function code		06H	
Holding register number	High	00H	} Any data within the range
	Low	C8H	
Write data	High	00H	
	Low	64H	
CRC-16	High	09H	
	Low	DFH	

Normal response message

Slave address		01H	} Contents will be the same as query message data.
Function code		06H	
Holding register number	High	00H	
	Low	C8H	
Write data	High	00H	
	Low	64H	
CRC-16	High	09H	
	Low	DFH	

Error response message

Slave address		01H
80H + Function code		86H
Error code		02H
CRC-16	High	C3H
	Low	A1H

5.6.3 Diagnostics (loopback test) [08H]

The master's query message will be returned as the response message from the slave. This function checks the communication system between the master and slave.

Example: Loopback test for slave address 1

Query message

Slave address		01H	
Function code		08H	
Test code	High	00H	} Test code must be set to 00.
	Low	00H	
Data	High	1FH	} Any pertinent data
	Low	34H	
CRC-16	High	E9H	
	Low	ECH	

Normal response message

Slave address		01H	} Contents will be the same as query message data.
Function code		08H	
Test code	High	00H	
	Low	00H	
Data	High	1FH	
	Low	34H	
CRC-16	High	E9H	
	Low	ECH	

Error response message

Slave address		01H
80H + Function code		88H
Error code		03H
CRC-16	High	06H
	Low	01H

5.6.4 Preset multiple registers [10H]

The query message specifies the starting register address and quantity of registers to be written. The write data is arranged in the query message with high-order 8 bits first and low-order 8 bits next. Only R/W holding registers can be specified.

Example: Data is written into the two holding registers from 00C8H to 00C9H of slave address 1.

Query message

Slave address		01H	
Function code		10H	
Starting number	High	00H	} First holding register address
	Low	C8H	
Quantity	High	00H	} The setting must be between 1 (0001H) and 100 (0064H).
	Low	02H	
Number of data		04H	→ Number of holding registers × 2
Data to first register	High	00H	} Any data within the range
	Low	64H	
Data to next register	High	00H	
	Low	64H	
CRC-16	High	BEH	
	Low	6DH	

Normal response message

Slave address		01H
Function code		10H
Starting number	High	00H
	Low	C8H
Quantity	High	00H
	Low	02H
CRC-16	High	C0H
	Low	36H

Error response message

Slave address		01H
80H + Function code		90H
Error code		02H
CRC-16	High	CDH
	Low	C1H

5.7 Data Configuration

5.7.1 Data range

The numeric range of data used in Modbus protocol is 0000H to FFFFH. Only the set value within the setting range is effective.



FFFFH represents -1.

Data processing with decimal points

■ Data with decimal points

● Data with one decimal place

The Modbus protocol does not recognize data with decimal points during communication.

Current transformer 1 input value	Cool-side manipulated output value *
Current transformer 2 input value *	Control loop break alarm (LBA)
Manipulated output value or heat-side manipulated output value	Heater break alarm 1 (HBA1)
	Heater break alarm 2 (HBA2) *

* This item does not use in the 3380.

Example: When the control loop break alarm set value is 8.0 minutes; 8.0 is processed as 80,
80 = 0050H

Control loop break alarm	High	00H
	Low	50H

■ Data without decimal points

Burnout	Used/unused of channels
Alarm 1 status	RUN/STOP transfer
Alarm 2 status	PID/AT selection
Alarm 3 status	Digital filter
Output status	Proportioning cycle time or heat-side proportioning cycle time
DI status	Cool-side proportional cycle time *
Memory area number selection	Scan interval time
Cool-side proportional band *	EEPROM storage mode
Integral time	EEPROM storage status
Derivative time	Lock level 1
Anti-reset windup	Lock level 2
Setting change rate limiter	

* This item does not use in the 3380.

Example: When integral time is 50 seconds; 50 is processed as 50, 50 = 0032H

Integral time	High	00H
	Low	32H

■ Data whose decimal point's presence and/or position depends on input range

The position of the decimal point changes depending on the input range type because the Modbus protocol does not recognize data with decimal points during communication.

The following data can have one of three decimal point positions:

- No decimal point
- One decimal place
- Two decimal place

Measured value (PV)

Set value monitor

Set value (SV)

Alarm 1 (Except the control loop break alarm)

Control loop break alarm (LBA)

Alarm 2 (Except the heater break alarm 1)

Alarm 3

Proportional band or heat-side proportional band

Overlap/deadband *

PV bias

* This item does not use in the 3380.

Example: When the temperature set value is -20.0 °F; -20.0 is processed as -200,

-200 = 0000H - 00C8H = FF38H

Set value (SV)	High	FFH
	Low	38H

5.7.2 Data processing precautions

- Addresses in which data (holding register) is accessible are from 0000H to 02EEH and from 1388H to 14A0H. If any address other than 0000H to 02EEH and 1388H to 14A0H is accessed, an error response message returns. However, no error returns for any address from 03E8H to 0563H. Therefore, do not access any of the above addresses.
- Read data of unused channel is 0.
- Any attempt to write to an unused channel is not processed as an error. Data can not be written into an unused channel.
- If data range or address error occurs during data writing, the data written before error is in effect.
- Communication data includes data which becomes RO (read only) depending on the specification. No error occurs even if data is written when set to RO. However in this case, no data is written.
 - ☞ For details, see **5.8 Communication Data List (P. 24)**.
- Send the next command message at time intervals of 30 bits after the master receives the response message.

5.8 Communication Data List

The communication data list summarizes names, descriptions, factory set values and attributes.



Attribute (RO: Read only, R/W: Read and Write)



The communication data whose name is marked with ★ indicates that corresponding to the memory area.



In case of Modbus communication, data are treated as binary data in communication.

Name	Data range	Factory set value	Attribute
Measured value (PV)	Within input range.	----	RO
Manipulated output value ¹	-5.0 to +105.0 %	----	RO
Cool-side manipulated output value (This item does not use in the 3380.)			
Current transformer 1 input value	CTL6P: 0.0 to 30.0 A CTL12: 0.0 to 100.0 A	----	RO
Current transformer 2 input value (This item does not use in the 3380.)			
STATUS ²	0 to 135	----	RO

¹ For heat/cool PID control: Heat-side manipulated output value

² The alarms and burnout statuses are converted to the corresponding decimal data, respectively and then are sent to the host computer. Convert the decimal data sent from the controller to the corresponding binary data (bit image) to confirm the status.

Bit number	Details	Alarm status
b0	Alarm 1 status	0: OFF 1: ON
b1	Alarm 2 status	
b2	Burnout status	
b3 to b6	Unused	
b7	Alarm 3 status	
b8 to b15	Unused	

Example:

Bit images	(Decimal number)	(Binary number)
OFF/ON status	135 =	0 0 0 0 0 0 0 0 1 0 0 0 0 1 1 1
Bit number		b15 b14 b13 b12 b11 b10 b9 b8 b7 b6 b5 b4 b3 b2 b1 b0



If any defect (welding, etc.) is found in the relay located inside the instrument, the output status may differ from the relay contact status.

Continued on the next page.

Continued from the previous page.

Name	Data range	Factory set value	Attribute
Output status ¹	0 to 2047	-----	RO
DI status ²	0 to 31	-----	RO

¹ The status of each output assigned to the controller is converted to the corresponding decimal data and then is sent to the host computer. Convert the decimal data sent from the controller to the corresponding binary data (bit image) to confirm the status.

Bit number	Assignment terminal	Output type	Terminal status
b0	OUT1	Control output or Alarm output	0: Open 1: Close
b1	OUT2		
b2	OUT3		
b3	OUT4		
b4	OUT5		
b5	OUT6		
b6	OUT7		
b7	OUT8		
b8	ALM1	Alarm output	
b9	ALM2		
b10	ALM3		

In case of current output (0 to 20 mA DC, 4 to 20 mA DC), these data becomes invalid.

Example:

Bit images	(Decimal number)	(Binary number)
Open/Close status	1792 =	1 1 1 0 0 0 0 0 0 0 0
Bit number		b10 b9 b8 b7 b6 b5 b4 b3 b2 b1 b0



If any defect (welding, etc.) is found in the relay located inside the instrument, the output status may differ from the relay contact status.

² The RUN/STOP terminal and memory area transfer contact input (DI) terminal statuses are converted to the corresponding decimal data, respectively and then are sent to the host computer. Convert the decimal data sent from the controller to the corresponding binary data (bit image) to confirm the status.

Bit number	Input type	Terminal status
b0	RUN/STOP terminal status	0: Open 1: Close
b1	DI1 terminal status	
b2	DI2 terminal status	
b3	DI4 terminal status	
b4	DI SET terminal status	

Example:

Bit images	(Decimal number)	(Binary number)
Open/Close status	18 =	1 0 0 1 0
Bit number		b4 b3 b2 b1 b0

Continued on the next page.

Continued from the previous page.

Name	Data range	Factory set value	Attribute
EEPROM storage status ¹	0: The content of the EEPROM does not coincide with that of the memory. 1: The content of the EEPROM coincides with that of the memory.	----	RO
Set value monitor	Within input range.	----	RO
Set value (SV) ★	Within input range.	0 or 0.0	R/W
PID/AT selection	0: PID control 1: Autotuning (AT)	0	R/W
Proportional band ² ★	0 (0.0) to span However, 9999 digits or less (0 or 0.0: ON/OFF action)	Temperature input: 30 or 30.0 Voltage input: 3.0	R/W
Cool-side proportional band ★ (This item does not use in the 3380.)	1 to 1000 % of heat-side proportional band	100	R/W ³
Integral time ★	0 to 3600 seconds (0: PD action)	240	R/W
Derivative time ★	0 to 3600 seconds (0: PI action)	60	R/W
Overlap/deadband ★ (This item does not use in the 3380.)	-span to +span ⁴ (Within -1999 to +9999 digits)	Temperature input: 0 or 0.0 Voltage input: 0.0	R/W ³
Anti-reset windup ★	0 to 100 % of heat-side proportional band (0: Integral action OFF)	100	R/W

¹ The contents of the buffer memory and those of the EEPROM can be checked.

When data is 0: The contents of the buffer memory do not match with those of the EEPROM.

- As data is being written to the EEPROM in backup mode, do not turn the power off. If turned off, no set values are stored.
- If the set value is changed after the backup mode is changed to the buffer mode, *I* is set (mismatch). As the set value changed is not backup, select the backup mode if necessary.

When data is 1: The contents of the buffer memory match with those of the EEPROM.

(Data write to the EEPROM is completed.)

² For heat/cool control: Heat-side proportional band³ In case of heat control, become RO (read only).⁴ Minus (-) setting results in overlap.

Continued on the next page.

Continued from the previous page.

Name	Data range	Factory set value	Attribute
Alarm 1 ★	Deviation alarm ¹ : -span to +span (Within -1999 to +9999 digits) Control loop break alarm (LBA): 0.0 to 200.0 minutes (0.0: LBA OFF)	Temperature input: 50 or 50.0 Voltage input: 5.0 Control loop break alarm: 8.0	R/W ²
Alarm 2 ³	Deviation alarm ¹ : -span to +span (Within -1999 to +9999 digits) Heater break alarm 1 (HBA1): 0.0 to 100.0 A (0.0: HBA1 OFF)	Temperature input: 50 or 50.0 Voltage input: 5.0 Heater break alarm 1: 0.0	R/W ⁴
Alarm 3 ★	Deviation alarm ¹ : -span to +span (Within -1999 to +9999 digits)	Temperature input: 50 or 50.0 Voltage input: 5.0	R/W ⁵
Heater break alarm 2 (HBA2) (This item does not use in the 3380.)	0.0 to 100.0 A (0.0: HBA2 OFF)	0.0	R/W ⁶
Used/unused of channels ★	0: Unused 1: Used for only alarm 2: Used for control and alarm	2	R/W

¹ Deviation alarm = Deviation high alarm, Deviation low alarm, Deviation high/low alarm, Band alarm,

Deviation high alarm (with hold action), Deviation low alarm (with hold action),
Deviation high/low alarm (with hold action)

² When the alarm 1 is FAIL alarm, attributes become RO (read only).

³ When the alarm 2 corresponds to heater break alarm 1 (HBA1), becomes communication data not corresponding to the memory area.

⁴ When there is not alarm 2, attributes becomes RO (read only).

When the alarm 2 is FAIL alarm, attributes become RO (read only).

⁵ When there is not alarm 3, attribute becomes RO (read only).

When the alarm 3 is FAIL alarm, attributes become RO (read only).

⁶ When the alarm 2 is other than heater break alarm 1 (HBA1), attributes become RO (read only).

Continued on the next page.

Continued from the previous page.

Name	Data range	Factory set value	Attribute
Proportioning cycle time ^{1,2}	1 to 100 seconds	Relay contact output: 20 Voltage pulse/ triac output: 2	R/W
Cool-side proportioning cycle time ² (This item does not use in the 3380.)	1 to 100 seconds	Relay contact output: 20 Voltage pulse/ triac output: 2	R/W ³
Control loop break alarm deadband (LBD) ★	0 to span However, 9999 digits or less (0: LBD OFF)	Temperature input: 0 or 0.0 Voltage input: 0.0	R/W ⁴
PV bias	-span to +span (Within -1999 to +9999 digits)	Temperature input: 0 or 0.0 Voltage input: 0	R/W
Digital filter	0 to 100 seconds (0: Digital filter OFF)	0	R/W
Setting change rate limiter ★	0 (0.0) to span/min. (0 or 0.0: Setting change rate limiter OFF)	0	R/W
RUN/STOP transfer	0: STOP 1: RUN	1	R/W
Memory area number selection	1 to 8	1	R/W
Scan interval time	1 to 10 seconds	2	R/W
Slave address ⁵	0 to 99	0	R/W
Communication speed ⁵	0: 2400 bps 1: 4800 bps 2: 9600 bps 3: 19200 bps	2	R/W

¹ For heat/cool control: Heat-side proportioning cycle time² In case of current output (0 to 20 mA DC, 4 to 20 mA DC), these data becomes invalid.³ In case of heat control, become RO (read only).⁴ Become RO (read only) when the alarm 1 is other than control loop break alarm (LBA).⁵ The value changed becomes effective when the power is turned on again or when changed from STOP to RUN.

Continued on the next page.

Continued from the previous page.

Name	Data range	Factory set value	Attribute
Data bit configuration ¹	See data bit configuration table ²	0	R/W
Interval time ¹	0 to 250 ms	10	R/W
EEPROM storage mode ³	0: Backup mode (Set values are store to the EEPROM) 1: Buffer mode (No set values are store to the EEPROM)	0	R/W

¹ The value changed becomes effective when the power is turned on again or when changed from STOP to RUN.

² Data bit configuration table

Set value	Data bit	Parity bit	Stop bit
0	8	Without	1
1	8	Without	2
2	8	Even	1
4	8	Odd	1

³ The non-volatile memory (EEPROM) has limitations on the number of memory rewrite times.

If the buffer mode is selected as an EEPROM storage mode, all of the set values changed are not written to the EEPROM and thus a problem of limitations on the number of memory rewrite times can be solved. When the memory is used to frequently change the set value via communication, select the buffer mode.

When selecting any EEPROM storage mode, take notice of the following.

- If power failure occurs while the buffer mode is selected, the set value returns to the value before the storage mode is selected.
- If the buffer mode is changed to the backup mode, all of the set values at that time are stored to the EEPROM. If necessary to backup the final value of each set item, select the backup mode.
- When the power is turned on, the backup mode is always set.

Continued on the next page.

Continued from the previous page.

Name	Data range	Factory set value	Attribute
Lock level 1	0000 to 1111 ¹	0000	R/W
Lock level 2	0000 to 1111 ²	0000	R/W

¹ Selection contents of lock level 1

0: Unlock 1: Lock

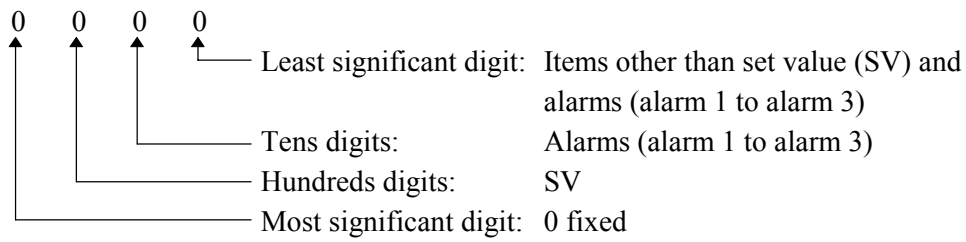

² Selection contents of lock level 2

0: Unlock 1: Lock

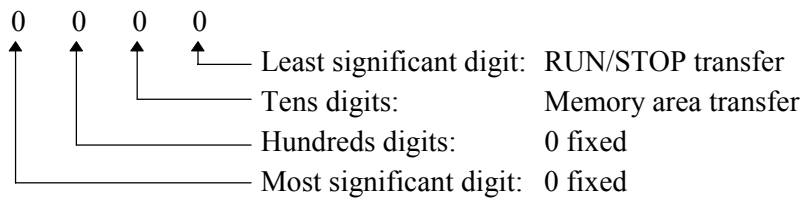

5.9 Data Map

5.9.1 Reference to data map

This data map summarizes the data addresses, channels and names that can be used with Modbus protocol. For details on each data range, see **5.8 Communication Data List (P. 24)**.

(1) ↓	(2) ↓	(3) ↓
Address	CH	Name
0000H (0)	CH1	Measured value (PV)
0001H (1)	CH2	
0002H (2)	CH3	
0003H (3)	CH4	
0004H (4) ⋮ 0013H (19)	—	Unused
0014H (20)	CH1	Manipulated output value *
0015H (21)	CH2	
0016H (22)	CH3	
0017H (23)	CH4	

(1) Address: Data addresses are written in hexadecimal numbers. Characters in () are decimal numbers.

(2) CH: The channel number of controller

(3) Name: Data names

5.9.2 Data map list

■ 3340 data map

(1) Read only data

Address	CH	Name
0000H (0)	CH1	Measured value (PV)
0001H (1)	CH2	
0002H (2)	CH3	
0003H (3)	CH4	
0004H (4) ⋮ 0013H (19)	—	Unused
0014H (20)	CH1	Manipulated output value *
0015H (21)	CH2	
0016H (22)	CH3	
0017H (23)	CH4	
0018H (24) ⋮ 0027H (39)	—	Unused
0028H (40)	CH1	Cool-side manipulated output value
0029H (41)	CH2	
002AH (42)	CH3	
002BH (43)	CH4	
002CH (44) ⋮ 003BH (59)	—	Unused
003CH (60)	CH1	Current transformer 1 input value
003DH (61)	CH2	
003EH (62)	CH3	
003FH (63)	CH4	
0040H (64)	CH1	Current transformer 2 input value
0041H (65)	CH2	
0042H (66)	CH3	
0043H (67)	CH4	
0044H (68) ⋮ 0063H (99)	—	Unused
0064H (100)	CH1	STATUS
0065H (101)	CH2	
0066H (102)	CH3	
0067H (103)	CH4	
0068H (104) ⋮ 0078H (120)	—	Unused

Address	CH	Name
0079H (121)	—	Output status
007AH (122)	—	DI status
007BH (123)	—	EEPROM storage status
007CH (124) ⋮ 008BH (139)	—	Unused
008CH (140)	CH1	Set value monitor
008DH (141)	CH2	
008EH (142)	CH3	
008FH (143)	CH4	
0090H (144) ⋮ 00C7H (199)	—	Unused

* For heat/cool control:

Heat-side manipulated output value.

(2) Read/Write data
(Data with channels)

Address	CH	Name
00C8H (200)	CH1	Set value (SV)
00C9H (201)	CH2	
00CAH (202)	CH3	
00CBH (203)	CH4	
00CCH (204) ⋮ 00DBH (219)	—	Unused
00DCH (220)	CH1	PID/AT selection
00DDH (221)	CH2	
00DEH (222)	CH3	
00DFH (223)	CH4	
00E0H (224) ⋮ 00EFH (239)	—	Unused
00F0H (240)	CH1	Proportional band For heat/cool control: Heat-side proportional band
00F1H (241)	CH2	
00F2H (242)	CH3	
00F3H (243)	CH4	
00F4H (244) ⋮ 0103H (259)	—	Unused
0104H (260)	CH1	Cool-side proportional band
0105H (261)	CH2	
0106H (262)	CH3	
0107H (263)	CH4	
0108H (264) ⋮ 0117H (279)	—	Unused
0118H (280)	CH1	Integral time
0119H (281)	CH2	
011AH (282)	CH3	
011BH (283)	CH4	
011CH (284) ⋮ 012BH (299)	—	Unused
012CH (300)	CH1	Derivative time
012DH (301)	CH2	
012EH (302)	CH3	
012FH (303)	CH4	
0130H (304) ⋮ 013FH (319)	—	Unused

Address	CH	Name
0140H (320)	CH1	Overlap/deadband
0141H (321)	CH2	
0142H (322)	CH3	
0143H (323)	CH4	
0144H (324) ⋮ 0153H (339)	—	Unused
0154H (340)	CH1	Anti-reset windup
0155H (341)	CH2	
0156H (342)	CH3	
0157H (343)	CH4	
0158H (344) ⋮ 0167H (359)	—	Unused
0168H (360)	CH1	Alarm 1
0169H (361)	CH2	
016AH (362)	CH3	
016BH (363)	CH4	
016CH (364) ⋮ 017BH (379)	—	Unused
017CH (380)	CH1	Alarm 2
017DH (381)	CH2	
017EH (382)	CH3	
017FH (383)	CH4	
0180H (384) ⋮ 018FH (399)	—	Unused
0190H (400)	CH1	Alarm 3
0191H (401)	CH2	
0192H (402)	CH3	
0193H (403)	CH4	
0194H (404) ⋮ 01A3H (419)	—	Unused
01A4H (420)	CH1	Heater break alarm 2
01A5H (421)	CH2	
01A6H (422)	CH3	
01A7H (423)	CH4	
01A8H (424) ⋮ 01B7H (439)	—	Unused

Continued on the next page.

Continued from the previous page.

Address	CH	Name
01B8H (440)	CH1	Used/unused of channels
01B9H (441)	CH2	
01BAH (442)	CH3	
01BBH (443)	CH4	
01BCH (444) ⋮ 01CBH (459)	—	Unused
01CCH (460)	CH1	Proportioning cycle time *
01CDH (461)	CH2	
01CEH (462)	CH3	
01CFH (463)	CH4	
01D0H (464) ⋮ 01DFH (479)	—	Unused
01E0H (480)	CH1	Cool-side proportioning cycle time
01E1H (481)	CH2	
01E2H (482)	CH3	
01E3H (483)	CH4	
01E4H (484) ⋮ 0243H (579)	—	Unused
0244H (580)	CH1	Control loop break alarm deadband (LBD)
0245H (581)	CH2	
0246H (582)	CH3	
0247H (583)	CH4	
0248H (584) ⋮ 0257H (599)	—	Unused
0258H (600)	CH1	PV bias
0259H (601)	CH2	
025AH (602)	CH3	
025BH (603)	CH4	
025CH (604) ⋮ 0293H (659)	—	Unused
0294H (660)	CH1	Digital filter
0295H (661)	CH2	
0296H (662)	CH3	
0297H (663)	CH4	
0298H (664) ⋮ 02A7H (679)	—	Unused

Address	CH	Name
02A8H (680)	CH1	Setting change rate limiter
02A9H (681)	CH2	
02AAH (682)	CH3	
02ABH (683)	CH4	
02ACH (684) ⋮ 02BBH (699)	—	Unused

* For heat/cool control:
Heat-side proportioning cycle time

(3) Read/Write data**(Data without channel)**

Address	CH	Name
02BCH (700)	—	RUN/STOP transfer
02BDH (701)	—	Memory area number selection
02BEH (702) ⋮ 02CFH (719)	—	Unused
02D0H (720)	—	Scan interval time
02D1H (721)	—	Device address
02D2H (722)	—	Communication speed
02D3H (723)	—	Data bit configuration
02D4H (724)	—	Interval time
02D5H (725)	—	EEPROM storage mode
02D6H (726)	—	Lock level 1
02D7H (727)	—	Lock level 2
02D8H (728) ⋮ 02EEH (750)	—	Unused

(4) Read/Write data**(Data corresponding to memory area)**

Address	CH	Name
1388H (5000)	—	Memory area number selection
1389H (5001)	CH1	Set value (SV)
138AH (5002)	CH2	
138BH (5003)	CH3	
138CH (5004)	CH4	
138DH (5005) ⋮ 139CH (5020)	—	Unused
139DH (5021)	CH1	Proportional band For heat/cool control: Heat-side proportional band
139EH (5022)	CH2	
139FH (5023)	CH3	
13A0H (5024)	CH4	
13A1H (5025) ⋮ 13B0H (5040)	—	Unused
13B1H (5041)	CH1	Integral time
13B2H (5042)	CH2	
13B3H (5043)	CH3	
13B4H (5044)	CH4	
13B5H (5045) ⋮ 13C4H (5060)	—	Unused
13C5H (5061)	CH1	Derivative time
13C6H (5062)	CH2	
13C7H (5063)	CH3	
13C8H (5064)	CH4	
13C9H (5065) ⋮ 13D8H (5080)	—	Unused
13D9H (5081)	CH1	Anti-reset windup
13DAH (5082)	CH2	
13DBH (5083)	CH3	
13DCH (5084)	CH4	
13DDH (5085) ⋮ 13ECH (5100)	—	Unused
13EDH (5101)	CH1	Setting change rate limiter
13EEH (5102)	CH2	
13EFH (5103)	CH3	
13F0H (5104)	CH4	

Address	CH	Name
13F1H (5105) ⋮ 1400H (5120)	—	Unused
1401H (5121)	CH1	Used/unused of channels
1402H (5122)	CH2	
1403H (5123)	CH3	
1404H (5124)	CH4	
1405H (5125) ⋮ 1414H (5140)	—	Unused
1415H (5141)	CH1	Cool-side proportional band
1416H (5142)	CH2	
1417H (5143)	CH3	
1418H (5144)	CH4	
1419H (5145) ⋮ 1428H (5160)	—	Unused
1429H (5161)	CH1	Overlap/deadband
142AH (5162)	CH2	
142BH (5163)	CH3	
142CH (5164)	CH4	
142DH (5165) ⋮ 143CH (5180)	—	Unused
143DH (5181)	CH1	Alarm 1
143EH (5182)	CH2	
143FH (5183)	CH3	
1440H (5184)	CH4	
1441H (5185) ⋮ 1450H (5200)	—	Unused
1451H (5201)	CH1	Control loop break alarm deadband (LBD)
1452H (5202)	CH2	
1453H (5203)	CH3	
1454H (5204)	CH4	
1455H (5205) ⋮ 1464H (5220)	—	Unused

Continued on the next page.

Continued from the previous page.

Address	CH	Name
1465H (5221)	CH1	Alarm 2
1466H (5222)	CH2	
1467H (5223)	CH3	
1468H (5224)	CH4	
1469H (5225) ⋮ 148CH (5260)	—	Unused
148DH (5261)	CH1	Alarm 3
148EH (5262)	CH2	
148FH (5263)	CH3	
1490H (5264)	CH4	
1491H (5265) ⋮ 14A0H (5280)	—	Unused



The accessible data (holding register) address range is from 0000H to 02EEH and 1388H to 14A0H. Addresses in which data (holding register) is accessible are from 0000H to 02EEH and from 1388H to 14A0H. If any address other than 0000H to 02EEH and 1388H to 14A0H is accessed, an error response message (error code: 2) returns. However, no error returns for any address from 03E8H to 0563H. Therefore, do not access any of the above addresses.

■ 3380 data map

(1) Read only data

Address	CH	Name
0000H (0)	CH1	Measured value (PV)
0001H (1)	CH2	
0002H (2)	CH3	
0003H (3)	CH4	
0004H (4)	CH5	
0005H (5)	CH6	
0006H (6)	CH7	
0007H (7)	CH8	
0008H (8) ⋮ 0013H (19)	—	Unused
0014H (20)	CH1	Manipulated output value
0015H (21)	CH2	
0016H (22)	CH3	
0017H (23)	CH4	
0018H (24)	CH5	
0019H (25)	CH6	
001AH (26)	CH7	
001BH (27)	CH8	
001CH (28) ⋮ 003BH (59)	—	Unused
003CH (60)	CH1	Current transformer 1 input value
003DH (61)	CH2	
003EH (62)	CH3	
003FH (63)	CH4	
0040H (64)	CH5	
0041H (65)	CH6	
0042H (66)	CH7	
0043H (67)	CH8	
0044H (68) ⋮ 0063H (99)	—	Unused
0064H (100)	CH1	STATUS
0065H (101)	CH2	
0066H (102)	CH3	
0067H (103)	CH4	
0068H (104)	CH5	
0069H (105)	CH6	
006AH (106)	CH7	
006BH (107)	CH8	

Address	CH	Name
006CH (108) ⋮ 0078H (120)	—	Unused
0079H (121)	—	Output status
007AH (122)	—	DI status
007BH (123)	—	EEPROM storage status
007CH (124) ⋮ 008BH (139)	—	Unused
008CH (140)	CH1	Set value monitor
008DH (141)	CH2	
008EH (142)	CH3	
008FH (143)	CH4	
0090H (144)	CH5	
0091H (145)	CH6	
0092H (146)	CH7	
0093H (147)	CH8	
0094H (148) ⋮ 00C7H (199)	—	Unused

(2) Read/Write data
(Data with channels)

Address	CH	Name
00C8H (200)	CH1	Set value (SV)
00C9H (201)	CH2	
00CAH (202)	CH3	
00CBH (203)	CH4	
00CCH (204)	CH5	
00CDH (205)	CH6	
00CEH (206)	CH7	
00CFH (207)	CH8	
00D0H (208) ⋮ 00DBH (219)	—	Unused
00DCH (220)	CH1	PID/AT selection
00DDH (221)	CH2	
00DEH (222)	CH3	
00DFH (223)	CH4	
00E0H (224)	CH5	
00E1H (225)	CH6	
00E2H (226)	CH7	
00E3H (227)	CH8	
00E4H (228) ⋮ 00EFH (239)	—	Unused
00F0H (240)	CH1	Proportional band
00F1H (241)	CH2	
00F2H (242)	CH3	
00F3H (243)	CH4	
00F4H (244)	CH5	
00F5H (245)	CH6	
00F6H (246)	CH7	
00F7H (247)	CH8	
00F8H (248) ⋮ 0117H (279)	—	Unused
0118H (280)	CH1	Integral time
0119H (281)	CH2	
011AH (282)	CH3	
011BH (283)	CH4	
011CH (284)	CH5	
011DH (285)	CH6	
011EH (286)	CH7	
011FH (287)	CH8	
0120H (288) ⋮ 012BH (299)	—	Unused

Address	CH	Name
012CH (300)	CH1	Derivative time
012DH (301)	CH2	
012EH (302)	CH3	
012FH (303)	CH4	
0130H (304)	CH5	
0131H (305)	CH6	
0132H (306)	CH7	
0133H (307)	CH8	
0134H (308) ⋮ 0153H (339)	—	Unused
0154H (340)	CH1	Anti-reset windup
0155H (341)	CH2	
0156H (342)	CH3	
0157H (343)	CH4	
0158H (344)	CH5	
0159H (345)	CH6	
015AH (346)	CH7	
015BH (347)	CH8	
015CH (348) ⋮ 0167H (359)	—	Unused
0168H (360)	CH1	Alarm 1
0169H (361)	CH2	
016AH (362)	CH3	
016BH (363)	CH4	
016CH (364)	CH5	
016DH (365)	CH6	
016EH (366)	CH7	
016FH (367)	CH8	
0170H (368) ⋮ 017BH (379)	—	Unused
017CH (380)	CH1	Alarm 2
017DH (381)	CH2	
017EH (382)	CH3	
017FH (383)	CH4	
0180H (384)	CH5	
0181H (385)	CH6	
0182H (386)	CH7	
0183H (387)	CH8	

Continued on the next page.

Continued from the previous page.

Address	CH	Name
0184H (388) ⋮ 018FH (399)	—	Unused
0190H (400)	CH1	Alarm 3
0191H (401)	CH2	
0192H (402)	CH3	
0193H (403)	CH4	
0194H (404)	CH5	
0195H (405)	CH6	
0196H (406)	CH7	
0197H (407)	CH8	
0198H (408) ⋮ 01B7H (439)	—	Unused
01B8H (440)	CH1	Used/unused of channels
01B9H (441)	CH2	
01BAH (442)	CH3	
01BBH (443)	CH4	
01BCH (444)	CH5	
01BDH (445)	CH6	
01BEH (446)	CH7	
01BFH (447)	CH8	
01C0H (448) ⋮ 01CBH (459)	—	Unused
01CCH (460)	CH1	Proportioning cycle time
01CDH (461)	CH2	
01CEH (462)	CH3	
01CFH (463)	CH4	
01D0H (464)	CH5	
01D1H (465)	CH6	
01D2H (466)	CH7	
01D3H (467)	CH8	
01D4H (468) ⋮ 0243H (579)	—	Unused
0244H (580)	CH1	Control loop break alarm deadband (LBD)
0245H (581)	CH2	
0246H (582)	CH3	
0247H (583)	CH4	
0248H (584)	CH5	
0249H (585)	CH6	
024AH (586)	CH7	
024BH (587)	CH8	

Address	CH	Name
024CH (588) ⋮ 0257H (599)	—	Unused
0258H (600)	CH1	PV bias
0259H (601)	CH2	
025AH (602)	CH3	
025BH (603)	CH4	
025CH (604)	CH5	
025DH (605)	CH6	
025EH (606)	CH7	
025FH (607)	CH8	
0260H (608) ⋮ 0293H (659)	—	Unused
0294H (660)	CH1	Digital filter
0295H (661)	CH2	
0296H (662)	CH3	
0297H (663)	CH4	
0298H (664)	CH5	
0299H (665)	CH6	
029AH (666)	CH7	
029BH (667)	CH8	
029CH (668) ⋮ 02A7H (679)	—	Unused
02A8H (680)	CH1	Setting change rate limiter
02A9H (681)	CH2	
02AAH (682)	CH3	
02ABH (683)	CH4	
02ACH (684)	CH5	
02ADH (685)	CH6	
02AEH (686)	CH7	
02AFH (687)	CH8	
02B0H (688) ⋮ 02BBH (699)	—	Unused

(3) Read/Write data**(Data without channel)**

Address	CH	Name
02BCH (700)	—	RUN/STOP transfer
02BDH (701)	—	Memory area number selection
02BEH (702) ⋮ 02CFH (719)	—	Unused
02D0H (720)	—	Scan interval time
02D1H (721)	—	Device address
02D2H (722)	—	Communication speed
02D3H (723)	—	Data bit configuration
02D4H (724)	—	Interval time
02D5H (725)	—	EEPROM storage mode
02D6H (726)	—	Lock level 1
02D7H (727)	—	Lock level 2
02D8H (728) ⋮ 02EEH (750)	—	Unused

(4) Read/Write data

(Data corresponding to memory area)

Address	CH	Name
1388H (5000)	—	Memory area number selection
1389H (5001)	CH1	Set value (SV)
138AH (5002)	CH2	
138BH (5003)	CH3	
138CH (5004)	CH4	
138DH (5005)	CH5	
138EH (5006)	CH6	
138FH (5007)	CH7	
1390H (5008)	CH8	
1391H (5009) ⋮ 139CH (5020)	—	
139DH (5021)	CH1	Proportional band
139EH (5022)	CH2	
139FH (5023)	CH3	
13A0H (5024)	CH4	
13A1H (5025)	CH5	
13A2H (5026)	CH6	
13A3H (5027)	CH7	
13A4H (5028)	CH8	
13A5H (5029) ⋮ 13B0H (5040)	—	Unused
13B1H (5041)	CH1	Integral time
13B2H (5042)	CH2	
13B3H (5043)	CH3	
13B4H (5044)	CH4	
13B5H (5045)	CH5	
13B6H (5046)	CH6	
13B7H (5047)	CH7	
13B8H (5048)	CH8	
13B9H (5049) ⋮ 13C4H (5060)	—	Unused
13B9H (5049) ⋮ 13C4H (5060)	—	Unused

Address	CH	Name
13C5H (5061)	CH1	Derivative time
13C6H (5062)	CH2	
13C7H (5063)	CH3	
13C8H (5064)	CH4	
13C9H (5065)	CH5	
13CAH (5066)	CH6	
13CBH (5067)	CH7	
13CCH (5068)	CH8	
13CDH (5069) ⋮ 13D8H (5080)	—	Unused
13D9H (5081)	CH1	Anti-reset windup
13DAH (5082)	CH2	
13DBH (5083)	CH3	
13DCH (5084)	CH4	
13DDH (5085)	CH5	
13DEH (5086)	CH6	
13DFH (5087)	CH7	
13E0H (5088)	CH8	
13E1H (5089) ⋮ 13ECH (5100)	—	Unused
13EDH (5101)	CH1	Setting change rate limiter
13EEH (5102)	CH2	
13EFH (5103)	CH3	
13F0H (5104)	CH4	
13F1H (5105)	CH5	
13F2H (5106)	CH6	
13F3H (5107)	CH7	
13F4H (5108)	CH8	
13F5H (5109) ⋮ 1400H (5120)	—	Unused

Continued on the next page.

Continued from the previous page.

Address	CH	Name
1401H (5121)	CH1	Used/unused of channels
1402H (5122)	CH2	
1403H (5123)	CH3	
1404H (5124)	CH4	
1405H (5125)	CH5	
1406H (5126)	CH6	
1407H (5127)	CH7	
1408H (5128)	CH8	
1409H (5129) ⋮ 143CH (5180)	—	Unused
143DH (5181)	CH1	Alarm 1
143EH (5182)	CH2	
143FH (5183)	CH3	
1440H (5184)	CH4	
1441H (5185)	CH5	
1442H (5186)	CH6	
1443H (5187)	CH7	
1444H (5188)	CH8	
1445H (5189) ⋮ 1450H (5200)	—	Unused
1451H (5201)	CH1	Control loop break alarm deadband (LBD)
1452H (5202)	CH2	
1453H (5203)	CH3	
1454H (5204)	CH4	
1455H (5205)	CH5	
1456H (5206)	CH6	
1457H (5207)	CH7	
1458H (5208)	CH8	
1459H (5209) ⋮ 1464H (5220)	—	Unused

Address	CH	Name
1465H (5221)	CH1	Alarm 2
1466H (5222)	CH2	
1467H (5223)	CH3	
1468H (5224)	CH4	
1469H (5225)	CH5	
146AH (5226)	CH6	
146BH (5227)	CH7	
146CH (5228)	CH8	
146DH (5229) ⋮ 148CH (5260)	—	Unused
148DH (5261)	CH1	Alarm 3
148EH (5262)	CH2	
148FH (5263)	CH3	
1490H (5264)	CH4	
1491H (5265)	CH5	
1492H (5266)	CH6	
1493H (5267)	CH7	
1494H (5268)	CH8	
1495H (5269) ⋮ 14A0H (5280)	—	Unused



The accessible data (holding register) address range is from 0000H to 02EEH and 1388H to 14A0H. Addresses in which data (holding register) is accessible are from 0000H to 02EEH and from 1388H to 14A0H. If any address other than 0000H to 02EEH and 1388H to 14A0H is accessed, an error response message (error code: 2) returns.

However, no error returns for any address from 03E8H to 0563H. Therefore, do not access any of the above addresses.

6. TROUBLESHOOTING



WARNING

- To prevent electric shock or instrument failure, always turn off the system power before replacing the instrument.
- To prevent electric shock or instrument failure, always turn off the power before mounting or removing the instrument.
- To prevent electric shock or instrument failure, do not turn on the power until all the wiring is completed.
- To prevent electric shock or instrument failure, do not touch the inside of the instrument.
- All wiring must be performed by authorized personnel with electrical experience in this type of work.

CAUTION

All wiring must be completed before power is turned on to prevent electric shock, instrument failure, or incorrect action.

The power must be turned off before repairing work for input break and output failure including replacement of sensor, contactor or SSR, and all wiring must be completed before power is turned on again.

This section lists some of the main causes and solutions for communication problems.

If you can not solve a problem, please contact Chromalox[®] Precision Heat and Control sales office or the agent, on confirming the type name and specifications of the product.

Problem	Probable cause	Solution
No response	Wrong connection, no connection or disconnection of the communication cable	Confirm the connection method or condition and connect correctly
	Breakage, wrong wiring, or imperfect contact of the communication cable	Confirm the wiring or connector and repair or replace the wrong one
	Mismatch of the setting data of communication speed and data bit configuration with those of the host	Confirm the settings and set them correctly
	Wrong address setting	

Continued on the next page.

Continued from the previous page.

Problem	Probable cause	Solution
No response	A transmission error (overrun error, framing error, parity error or CRC-16 error) is found in the query message	Re-transmit after time-out occurs or verify communication program
	The time interval between adjacent data in the query message is too long, exceeding 24 bits' time	
Error code 1	Function cod error (Specifying nonexistent function code)	Confirm the function code
Error code 2	When any address other than 0000H to 02EEH and 1388H to 14A0H are specified (However, no error returns for any address from 03E8H to 0563H. Therefore, do not access any of the above addresses.)	Confirm the address of holding register
Error code 3	When the specified number of data items in the query message exceeds the maximum number of data items available	Confirm the setting data
Error code 4	Self-diagnostic error	Turn off the power to the instrument. If the same error occurs when the power is turned back on, please contact Chromalox® Precision Heat and Control sales office or the agent.

MEMO

Chromalox[®]

PRECISION HEAT AND CONTROL

1382 Heil-Quaker Blvd., LaVergne, TN 37086

PHONE: 615-793-3900

FAX: 615-793-3563

WEB: www.mychromalox.com