

Installation Instructions

RTBC-EP Power Connection Kit with Integral Thermostat

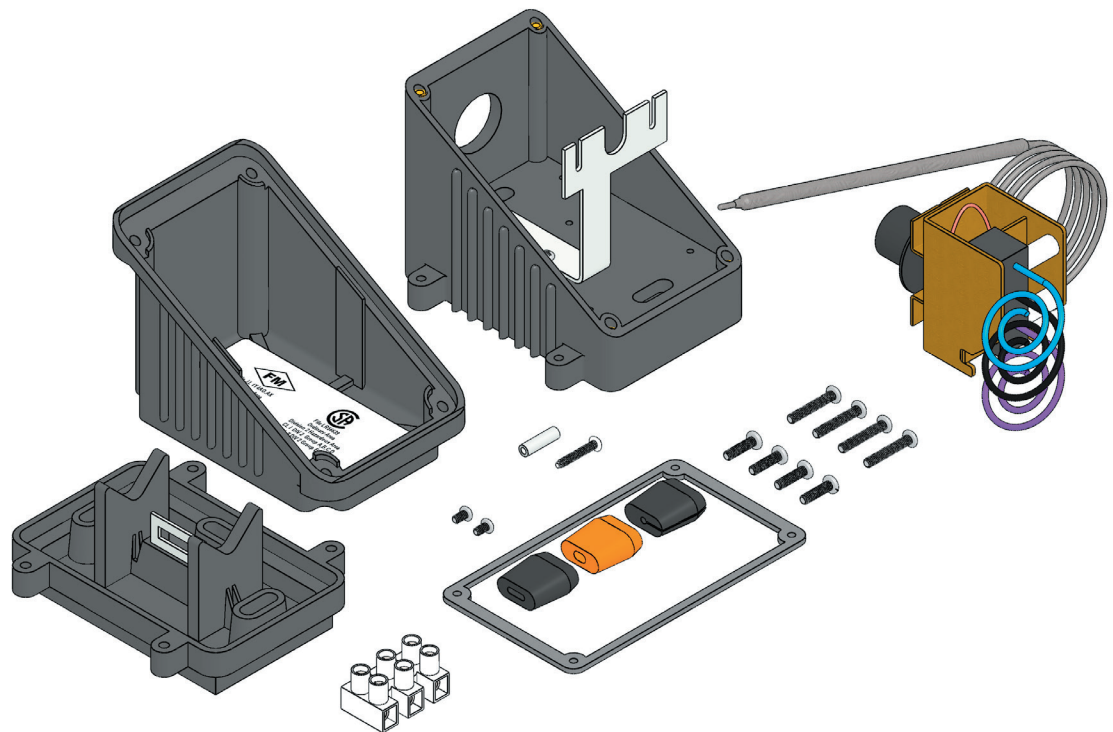

PJ973
161-562765-004
May, 2021

RTBC-EP Power Connection Kit

Installation Instructions

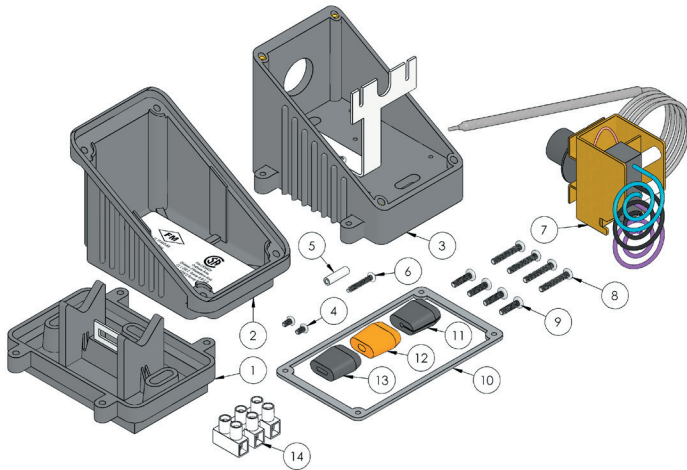

Item	Qty.	Description
1	1	Junction Box Base
2	1	Junction Box Lid
3	1	Junction Box
4	2	Thermostat Mounting Screws
5	1	Butt Splice
6	1	Terminal Block Mounting Screw
7	1	Thermostat 8" Capillary - 22A
8	4	Box Screws 1" Long
9	4	Cover Screws 5/8" Long
10	1	Cover Gasket
11	1	Capillary Grommet
12	1	Orange Constant Wattage Grommet
13	1	Black Self-Regulating Cable Grommet
14	1	Terminal Block
15	1	8" of 14AWG Insulated Wire

General

RTBC-EP is a power connection kit with an integral line sensing thermostat.

The NEMA4X power connection enclosure is constructed of corrosion resistant Ryton®, that features an oblique sided box to allow easy access to terminal block and thermostat settings. The enclosure includes a 3/4" opening on the side for customer provided conduit hub. The RTBC-EP base features a waterproof cableway for the heating cable and capillary to enter the enclosure from underneath to protect the cables and thermostat from damage. The base includes a stainless steel tie down to mounting tab to strap the kit to the piping with a stainless steel pipe strap (PS). Inside the enclosure is a three-position terminal block for connecting the line voltage and heating cable together and

the line sensing thermostat that includes a dial temperature control knob. The RTBC-EP lid is sealed with a gasket and screws on each corner.

Certifications & Approvals

Type 4X -60°C<Ta<+55°C
 Ordinary & Hazardous Locations
 Class I, Division 2 Groups A*,B,C&D
 Class II, Division 2 Groups F & G
 *CSA only



Tools Required for Kit Installation



Order Separately

UL Certified Pipe Straps

- Pipe Strap: 1/2" to 3/4" pipes SS
- Pipe Strap: 1" to 3-1/2" pipes SS
- Pipe Strap: 2-1/2" to 9" pipes SS
- Pipe Strap: 9" to 19.5" pipes SS



Caution Label Fiberglass Tape



Actual Kit Dimensions

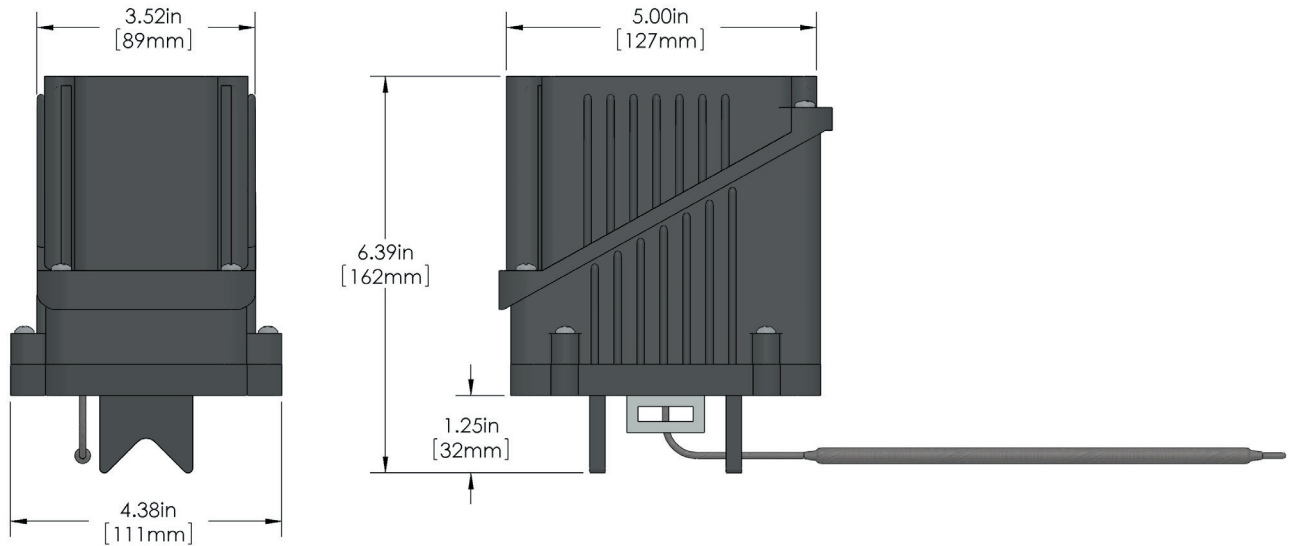

⚠ WARNING

HAZARD OF ELECTRIC SHOCK. Disconnect all power before starting. All installations must be effectively grounded in accordance with the National Electrical Code to eliminate shock hazard.

⚠ WARNING

Turn off power before removing junction box cover at all times.

⚠ WARNING

Users should install adequate controls and safety devices with their electric heating equipment. Where the consequences of failure may be severe, back-up controls are essential. Although the safety of the installation is responsibility of the user, Chromalox will be glad to assist in making equipment recommendations.

⚠ WARNING

Keep ends of heating devices and kit components dry before and during installation.

⚠ WARNING

Ground fault equipment protection is required for each circuit.

⚠ WARNING

The presence of the heating devices shall be made evident by the posting of caution signs or markings at appropriate locations and/or at frequent intervals along the circuit.

Cable installation instructions: CPR, CPM, SRL, SRM/E, SRP CHZ, CWM cable special instructions denoted by *

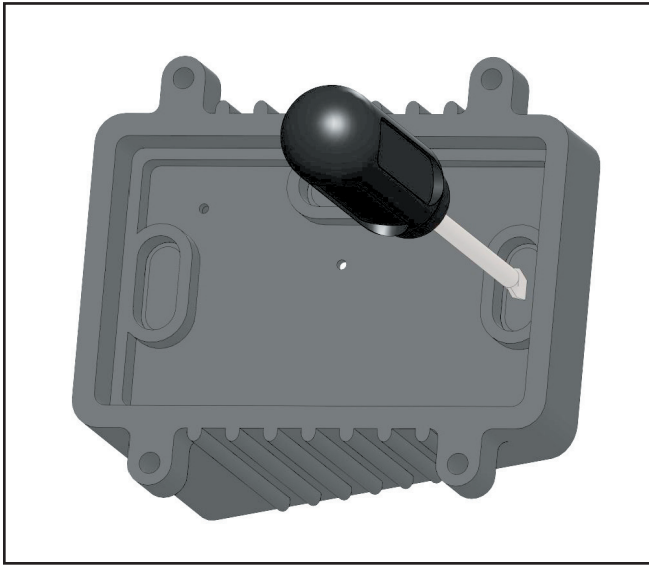

1. Use a hammer and screwdriver to punch out the knockouts on the bottom of the box which correspond to the openings in the base through which the heating cable and bulb & capillary passes. Only punch out the knockouts that are to be used. If one is mistakenly punched, blank grommets can be ordered to re-establish the water tight seal.

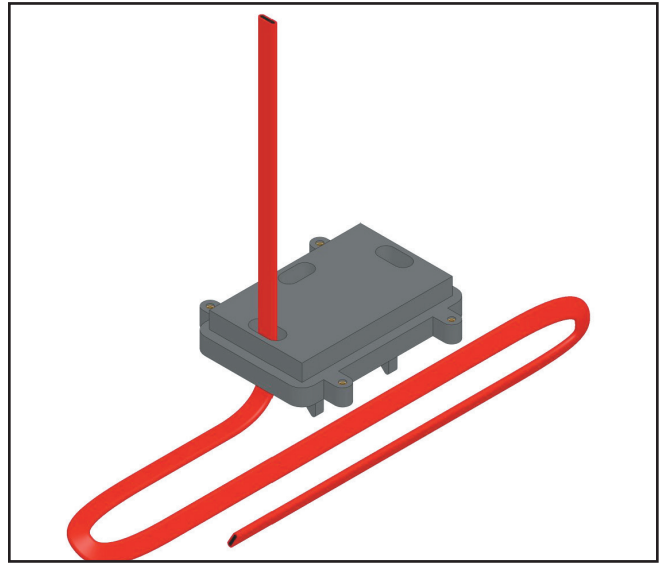

2. Feed the ends of the cables through the appropriate hole in the base. Allow 8" of cable to extend above the top of the base.

*If using CZH, CWM cut the cable 12" past the module point (indicated by indentation in cable) before completing this step. Cutting cable between module points creates a non-heating cold lead.

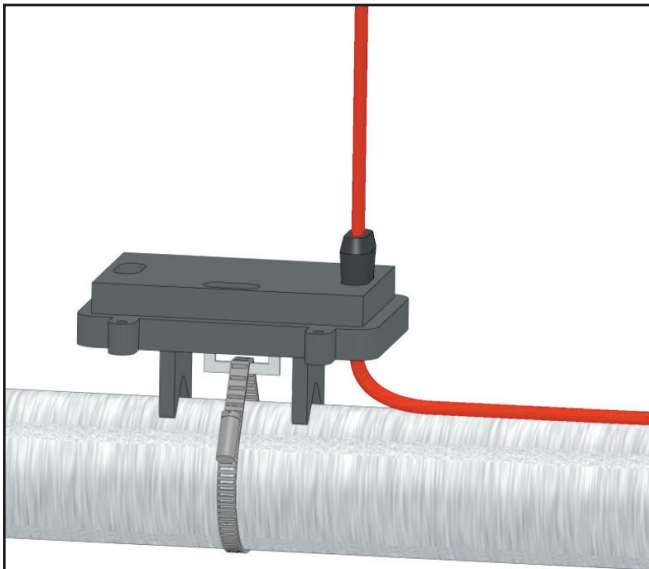

3. Secure the base to the pipe by threading the appropriate sized pipe strap through the slot in the mounting plate. Tighten the pipe strap until the base is securely attached to the pipe.

Slide the grommet over the cable until it reaches the base of the box.

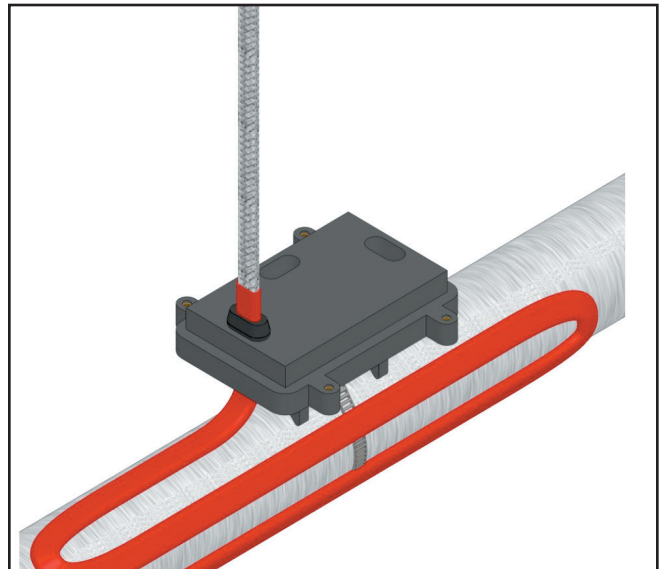

4. Score the outer insulation 1-1/2" from the end of the cable. Remove the jacket to expose the metal braid. **CAUTION:** When removing outer jacket, be careful not to damage the braid of the base cable insulation.

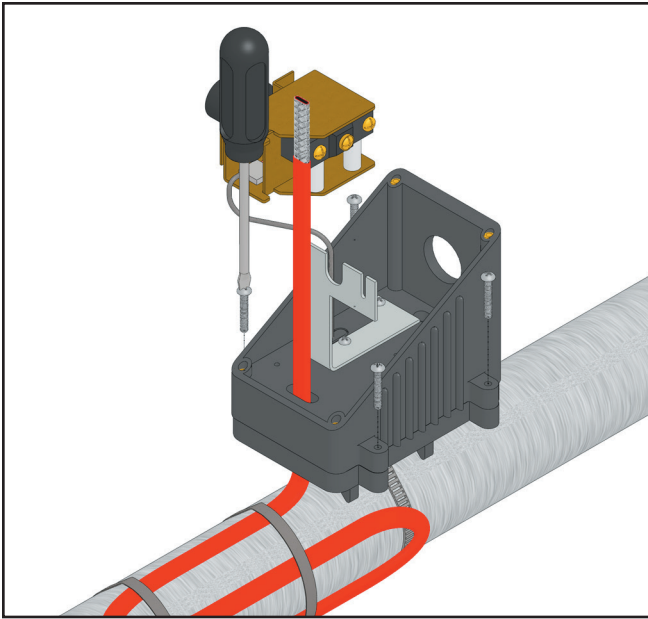

5. Feed the capillary of the thermostat through the side hole of the box. Slip the grommet over the capillary between the box and the base. Feed the cable through the end hole in the box. Allow 3/4" of stainless steel capillary to extend above the bottom of the box. Secure box to base using all four larger (8-32) screws.

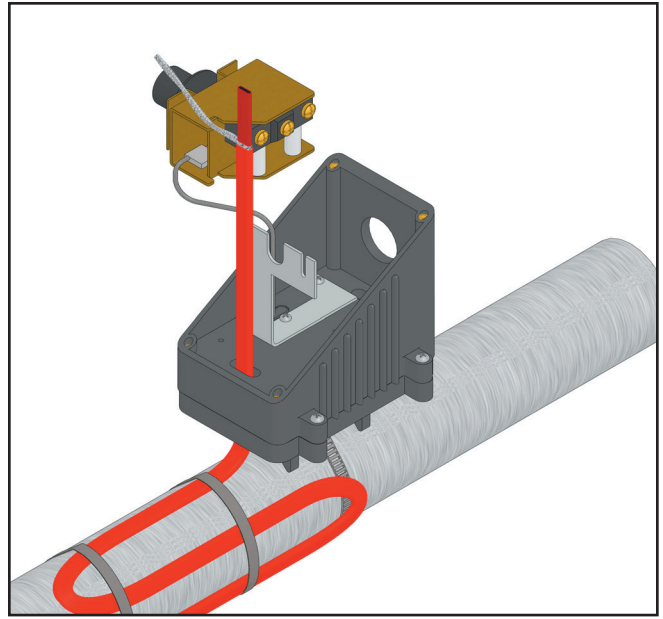

6. Starting from the end of the cable, unravel 1-1/2" of the braid. Twist the strands together to form a pigtail.

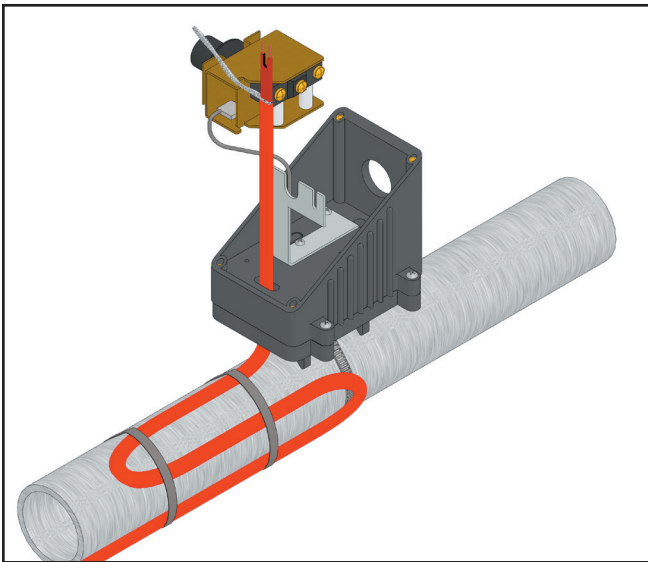

7. Using standard electrical cutters, cut a 3/4" long notch out of the cable between the conductor wires. Bare a 3/8" length of each conductor by stripping off the outside insulation and the inner black core material.

*If using CZH, CWM score the outer jacket 3/4" from the end of the cable and remove the jacket. Cut off the exposed nichrome wire, pushing any remainder back under the jacket. Separate the buss wires and strip off the last 3/8" of the insulation from around both buss wires.

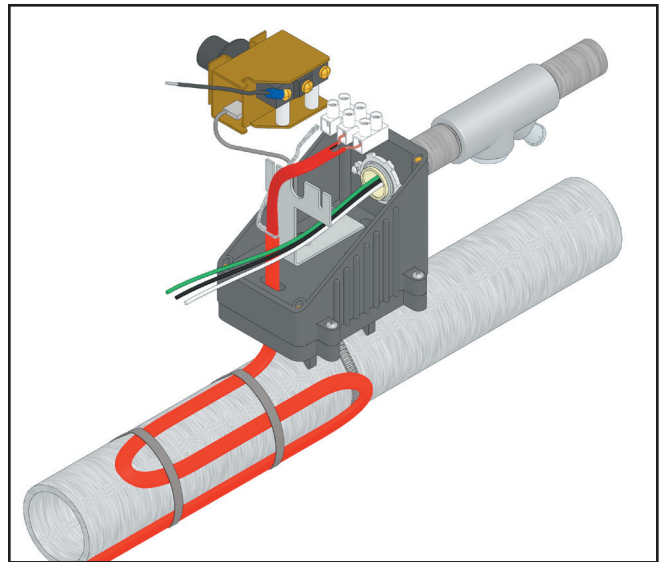

8. Insert the bared ends of the conductors into the openings in the terminal block. Tighten screws firmly to hold the wires in place. Attach UL certified conduit to hub and bring power leads into box. Strip 3/8" length of each power wiring. Connect conduit hub (Chromalox CCH-1, CH-75 or equal) to the box. Attach conduit to hub and bring 8" of power leads into the box.

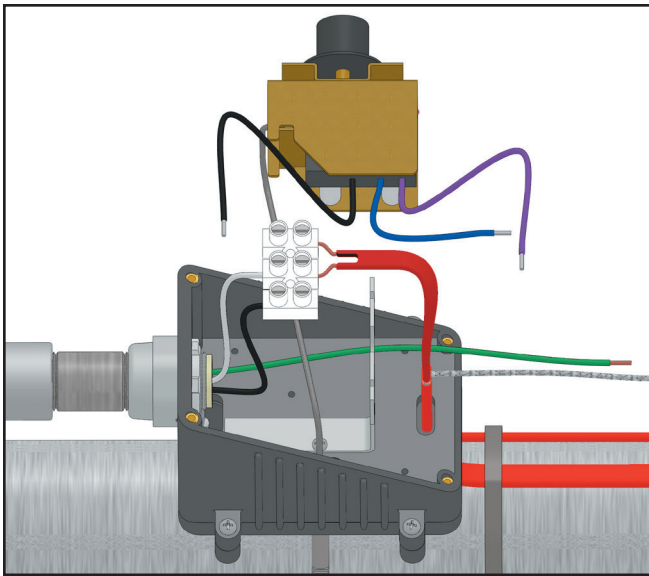

9. Slide the bared end of the hot power lead into the opening in the terminal block which is opposite of the empty terminal. Slide the bared end of the other hot or neutral power lead into the middle opening of the terminal block. Tighten the screws firmly to hold the wires in place

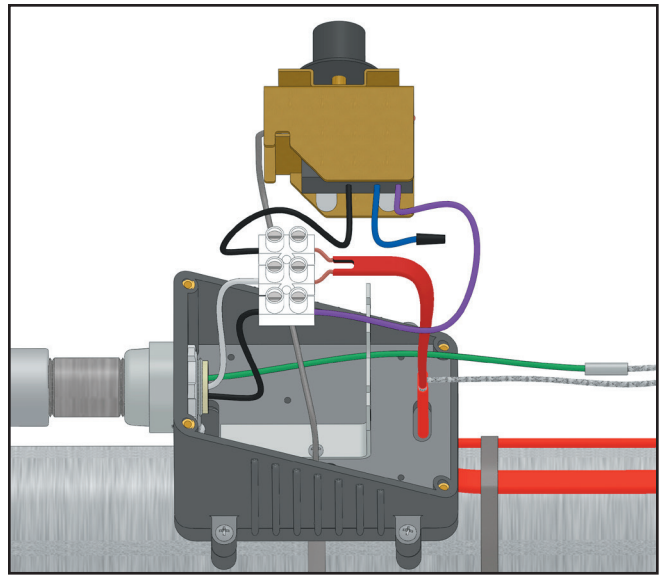

10. A. Slide the bared end of the black (NORMALLY CLOSED) thermostat wire into the opening of the terminal block which is next to the incoming power leads.
 B. Slide the bared end of the purple (COMMON) thermostat wire into the opening opposite of the hot power lead. Tighten the screws firmly to hold the wires in place.
 C. Trim the (NORMALLY OPEN) thermostat wire so that it is only two 2" long. Tape over the end of the wire using fiberglass tape.
 D. Slide the bared end of the ground wire into the end of the uninsulated barrel connector (Item 5). Crimp it on using a crimping tool. Slide the end of the braid pigtail into the other end of the uninsulated barrel connector and crimp it on. See wiring diagram on page 8.

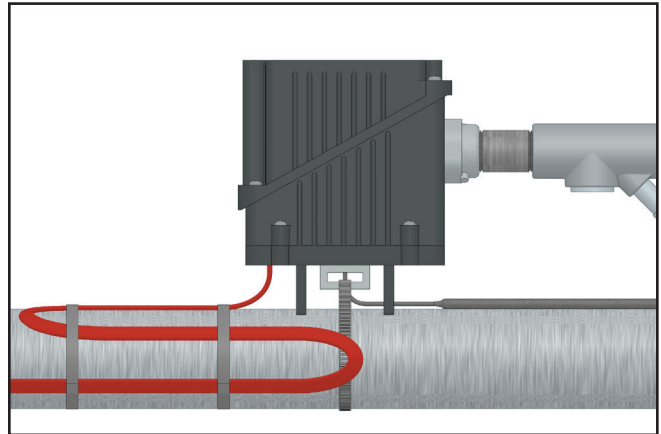
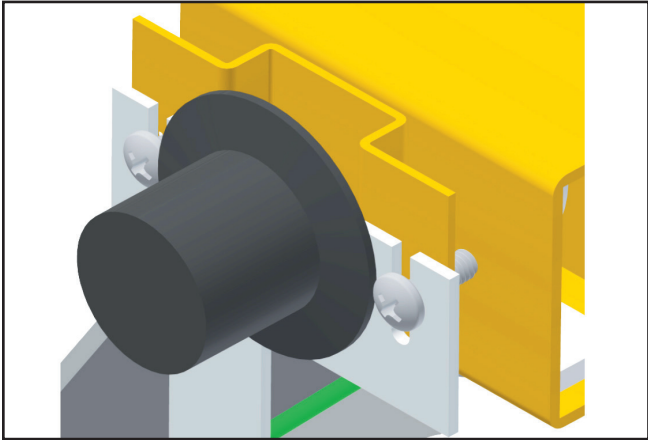
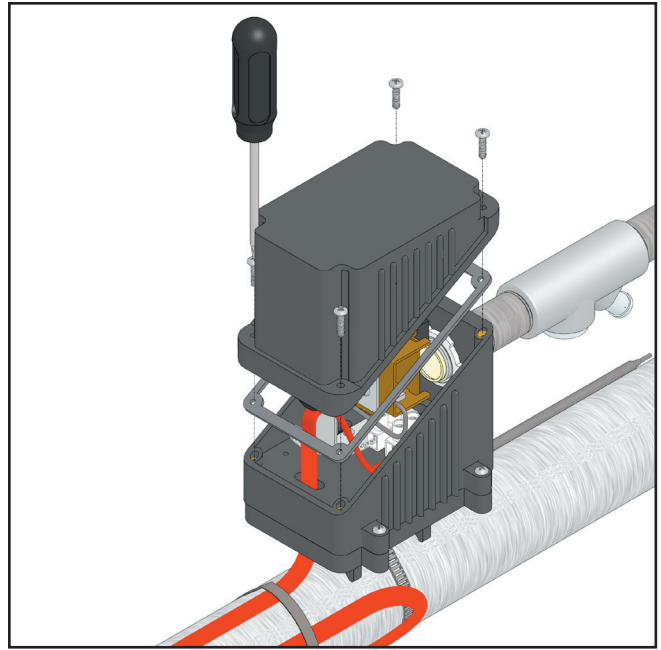
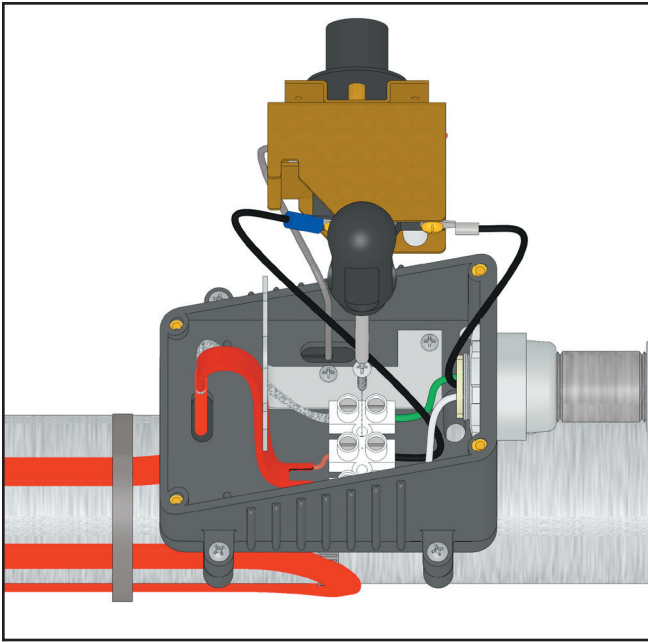

11. Mount terminal block to bottom of the box by driving the self-tapping screw provided into the mounting hole as shown. Thread the screws into the outside pair of mounting holes of the thermostat leaving approximately 1/8" of thread. Slide the screws into the slots in the mounting bracket. Push the thermostat down as far as it will go and tighten the screws firmly.

12. Carefully push all the wires into the box and secure the lid to the box. Make sure water tight rubber gasket (Item 10) is in place. The thermostat is shipped factory preset and pre-calibrated for 40°F operation. The setting may be changed by rotating the white knobs until the desired temperature is directly behind the setting post. Extend capillary to allow bulb to be placed in desired location. The bulb should be placed on the bottom half of the pipe spaced 90 degrees from the nearest heating cable or centered between equally.

Do not locate the bulb within three feet of a pipe support or other heat sink.

Wiring Diagrams

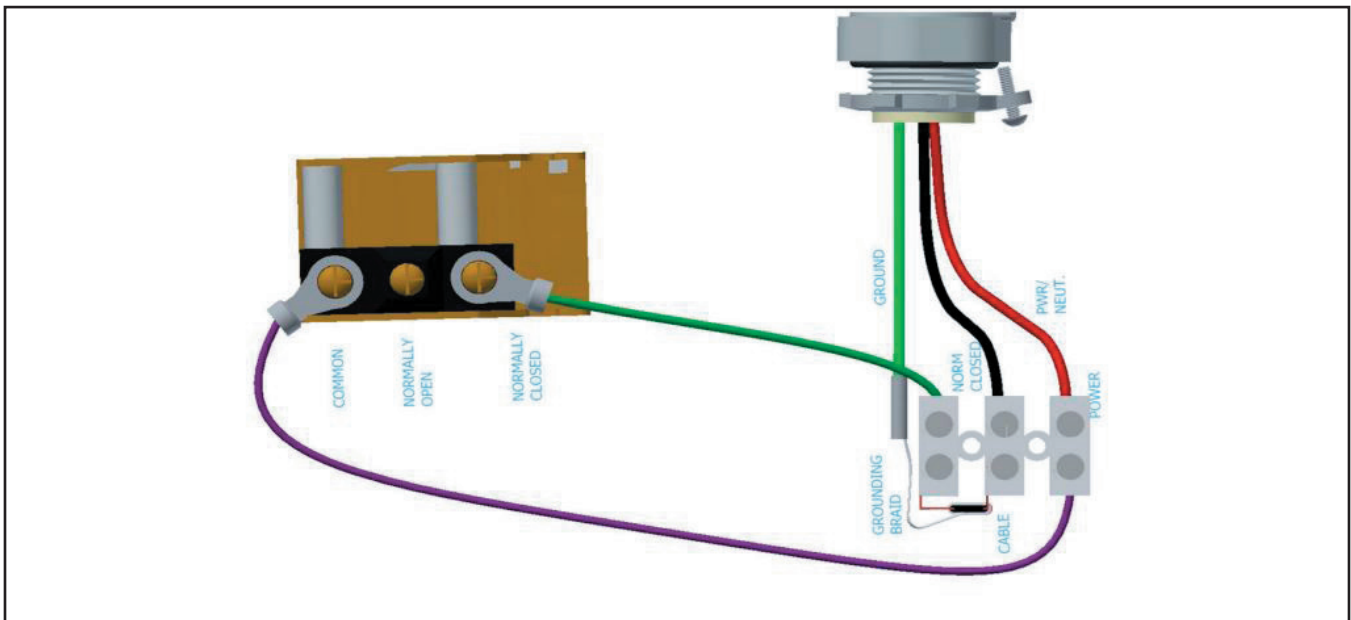
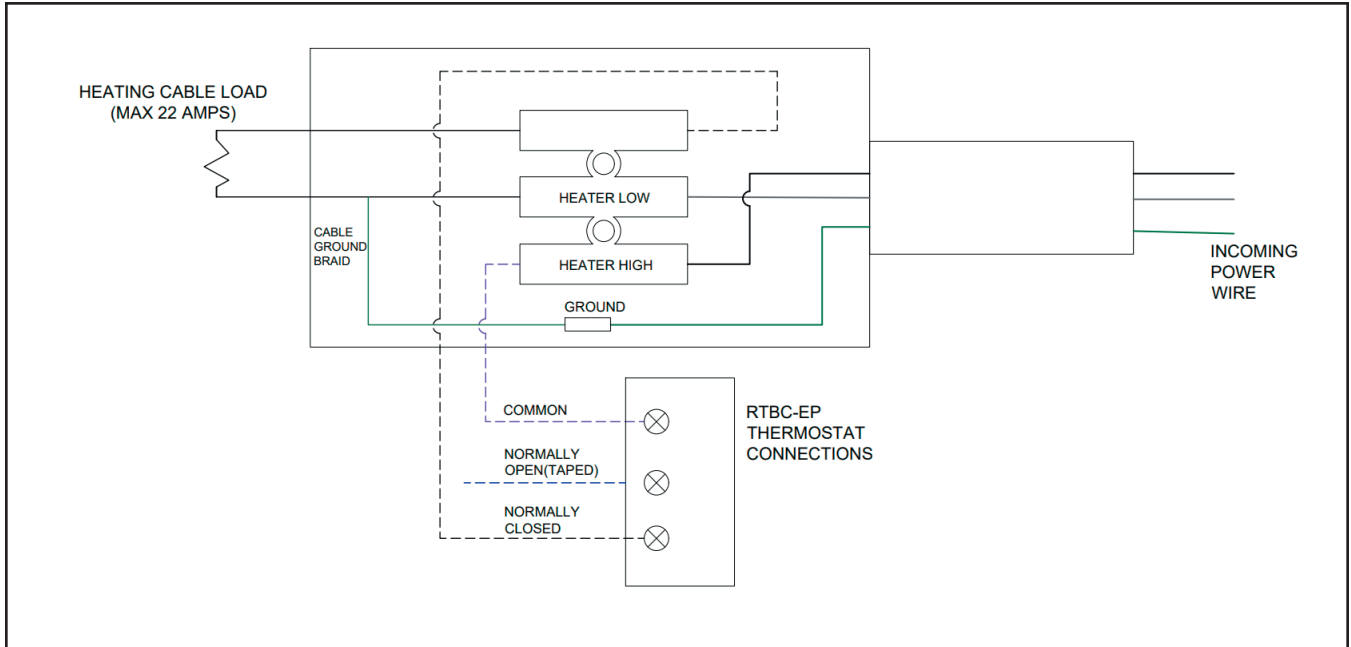

Limited Warranty:

Please refer to the Chromalox limited warranty applicable to this product at http://www.chromalox.com/customer-service/policies/terms_of_sale.aspx.

Chromalox, Inc.
1347 Heil Quaker Boulevard
Lavergne, TN 37086
(615) 793-3900
www.chromalox.com