

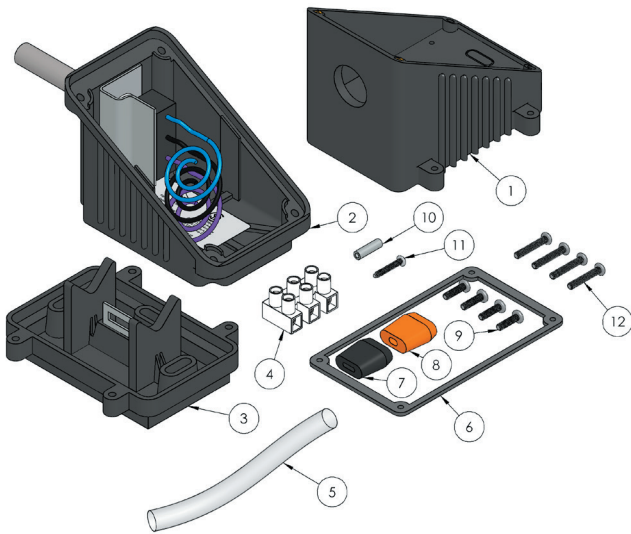

# RTAS-EP Power Connection Kit

## With Integral Thermostat Installation Instructions



Item	Qty	Description
1	1	Junction Box
2	1	Junction Box Lid
3	1	Junction Box Base
4	1	Three Position Terminal Block
5	1	6" Length of Insulating Tubing
6	1	Cover Gasket
7	1	Black Self-Regulating Cable Grommet
8	1	Orange Constant Wattage Grommet
9	4	Cover Screws 5/8" Long
10	1	Butt Splice
11	1	Mounting Screw for Terminal Block
12	4	Box Screw, 1" Long

### General

These kits are designed to provide temperature control as well as termination for one run of Chromalox Self-regulating or Constant Wattage Heating Cable.

Each kit contains enough material to connect one cable. One additional self-regulating cable can be connected; an extra grommet is required.

### Certifications & Approvals

Type 4X -60°C<Ta<+55°C  
 Ordinary & Hazardous Locations  
 Class I, Division 2 Groups A\*,B,C&D  
 Class II, Division 2 Groups F & G  
 \*CSA only



### Tools Required for Kit Installation



### Order Separately

#### Pipe Straps

- Pipe Strap: 1/2" to 3/4" pipes
- Pipe Strap: 1" to 3-1/2" pipes
- Pipe Strap: 2-1/2" to 9" pipes
- Pipe Strap: 9" to 19.5" pipes



#### Caution Label Fiberglass Tape



## Actual Kit Dimensions

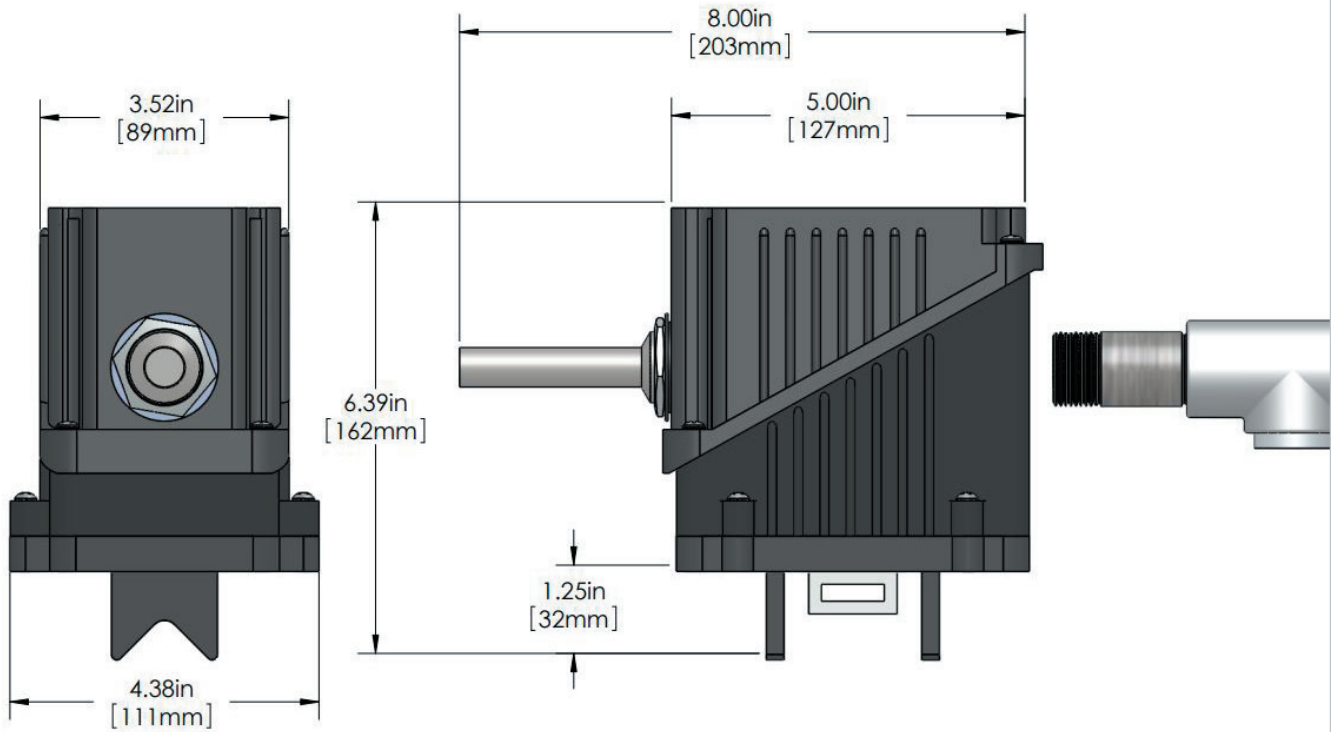

### **⚠ WARNING**

**HAZARD OF ELECTRIC SHOCK. Disconnect all power before starting. All installations must be effectively grounded in accordance with the National Electrical Code to eliminate shock hazard.**

### **⚠ WARNING**

**Turn off power before removing junction box cover at all times.**

### **⚠ WARNING**

**Users should install adequate controls and safety devices with their electric heating equipment. Where the consequences of failure may be severe, back-up controls are essential. Although the safety of the installation is responsibility of the user, Chromalox will be glad to assist in making equipment recommendations.**

## Cable Installation Instructions: CPR, CPM, SRL, SRM/E, SRP CZH, CWM cable special instructions denoted by \*

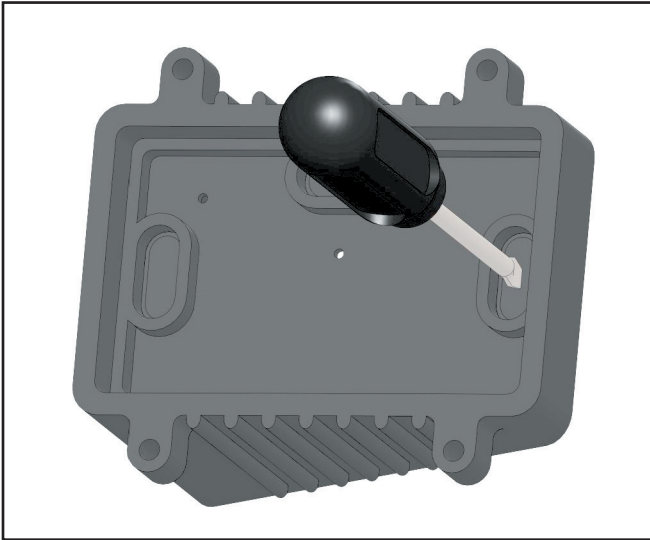

1. Use a hammer and screwdriver to punch out the knockouts on the bottom of the box which correspond to the openings in the base through which the heating cable passes. Only punch out the knockouts that are to be used. If one is mistakenly punched, blank grommets can be ordered to re-establish the water tight seal.

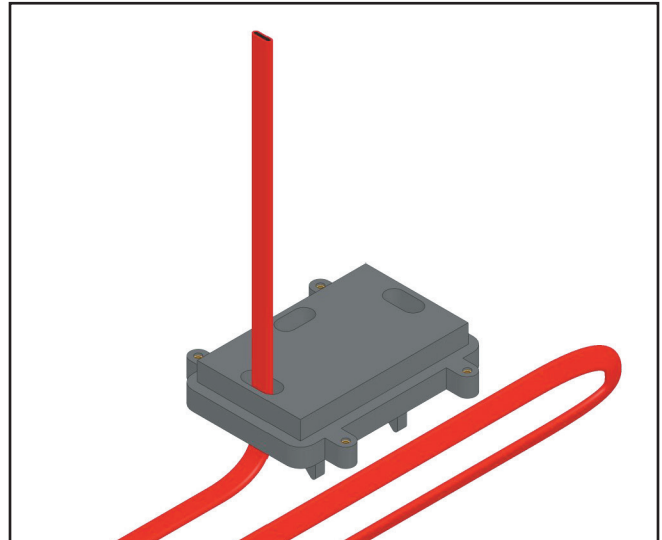

2. Feed the ends of the cables through the appropriate hole in the base. Allow 8" of cable to extend above the top of the base.

\*If using CZH, CWM cut the cable 12" past the module point (indicated by indentation in cable) before completing this step. Cutting cable between module points creates a non-heating cold lead.

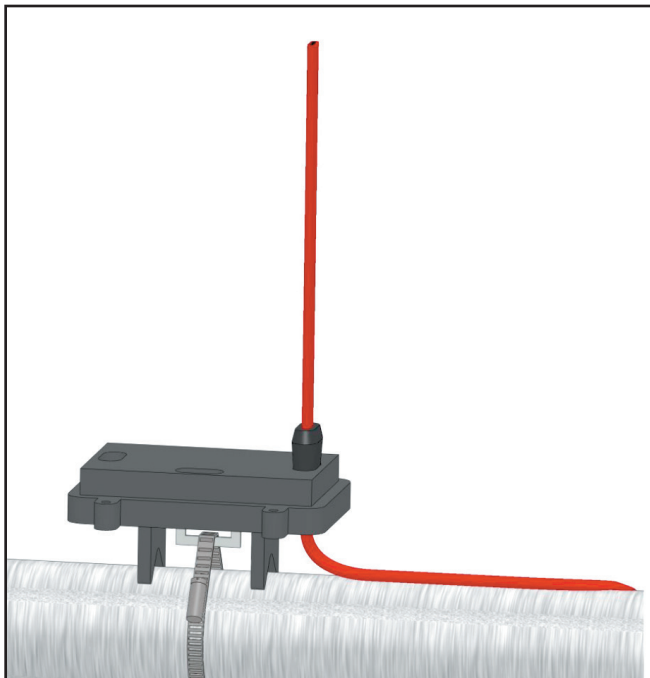

3. Slide cable grommet over the end of the cable and insert it into the opening in the base. Secure the base to the pipe by threading the appropriate sized pipe strap through the slot in the mounting plate. Tighten the pipe strap until the base is securely attached to the pipe.

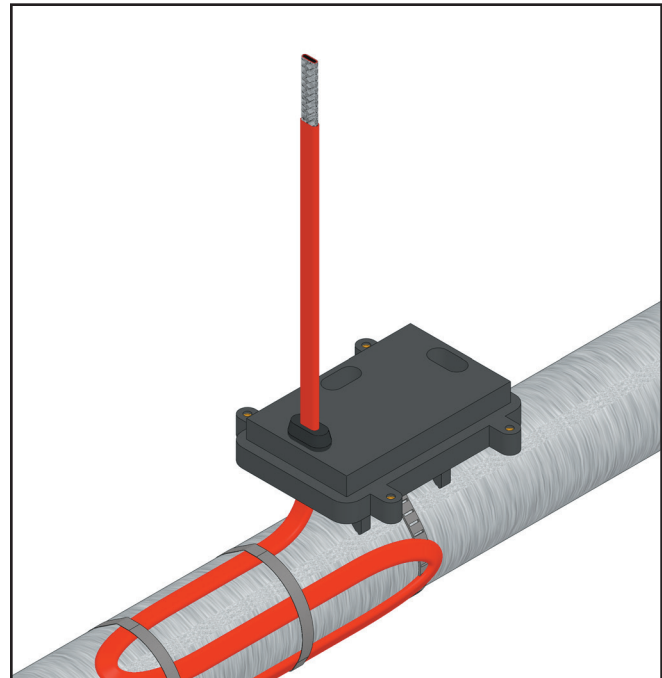

4. For overcoated cables, score the outer insulation 1-1/2" from the end of the cable. Remove the jacket to expose the metal braid. **CAUTION: When removing outer jacket, be careful not to damage the braid of the base cable insulation.**

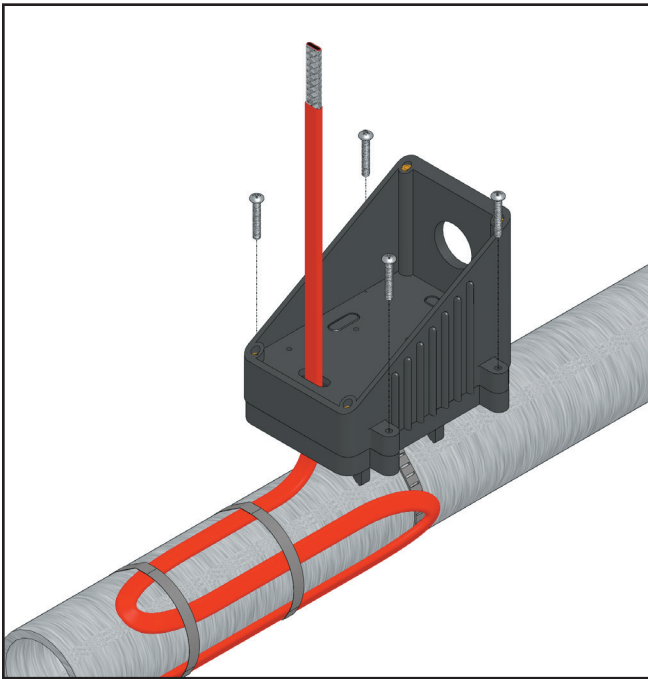

5. Feed cables through the corresponding holes in the box and secure box to base using all four of the 1" long screws.

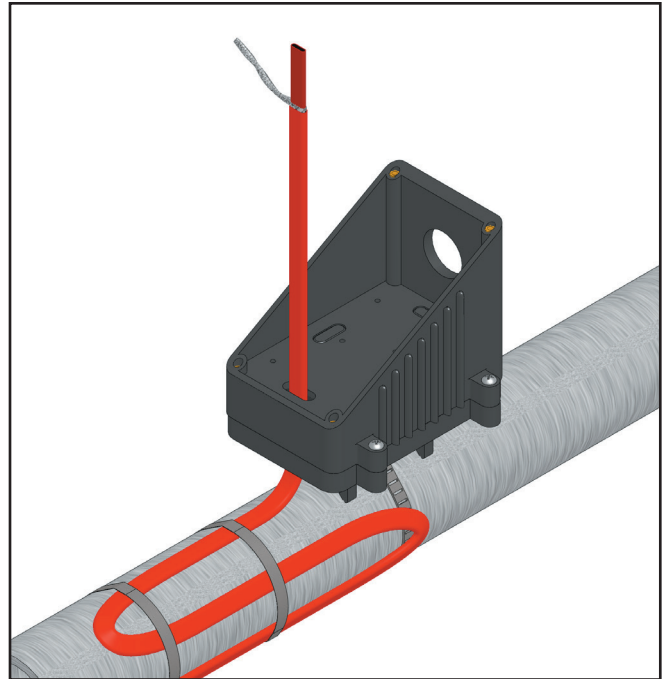

6. Starting from the end of the cable, unravel 1-1/2" of the braid. Twist the strands together to form a pigtail.

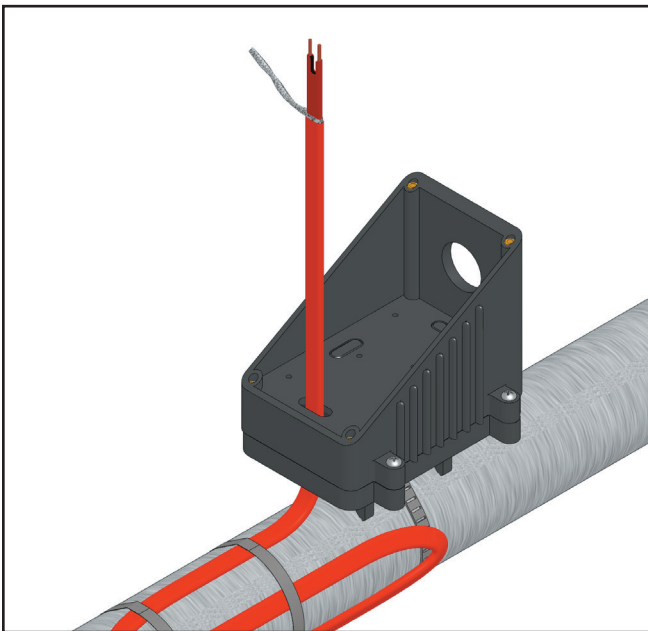

7. Using standard electrical cutters, cut a 3/4" long notch out of the cable between the conductor wires. Bare a 3/8" length of each conductor by stripping off the outside insulation and the inner black core material.

\*If using CZH, CWM score the outer jacket 3/4" from the end of the cable and remove the jacket. Cut off the exposed nichrome wire, pushing any remainder back under the jacket. Separate the buss wires and strip off the last 3/8" of the insulation from around both buss wires.

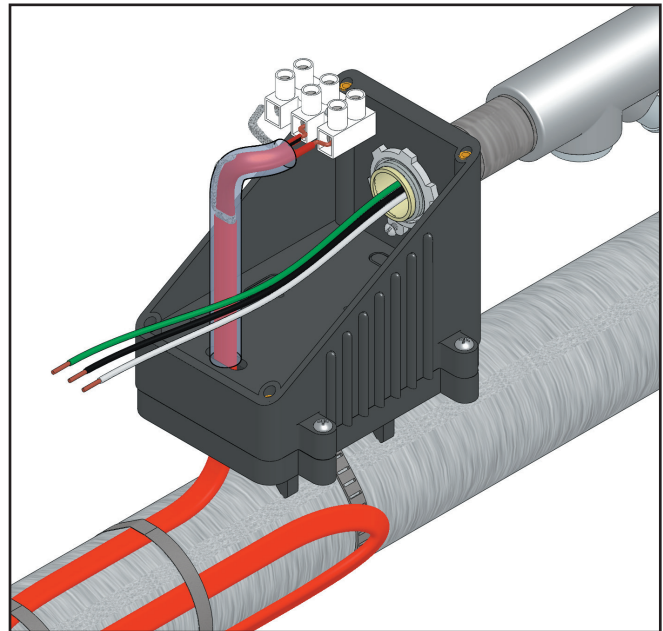

8. Slide the 6" insulation tubing over the cable. Insert the bared ends of the conductors and the braid into the openings in the terminal block. Tighten screws firmly to hold the wires in place. Connect conduit hub (Chromalox CCH, CH-75 or equal) to the box. Attach conduit to hub and bring power leads into box. Strip 3/8" length of each power wiring.

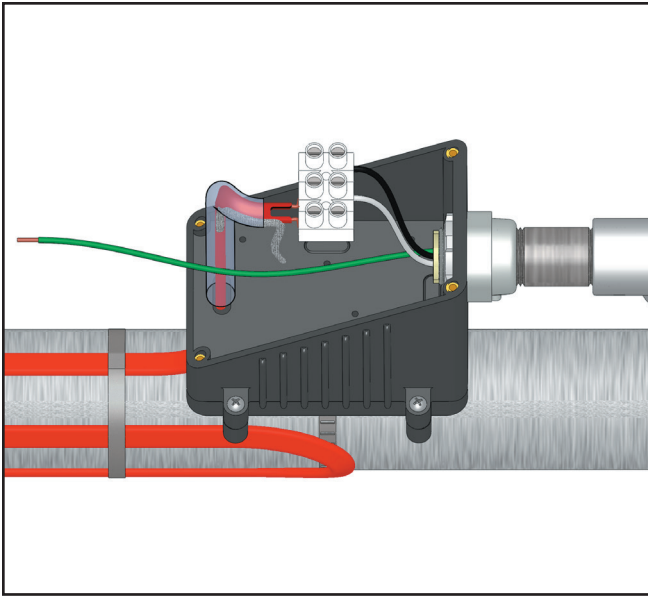

9. Slide the bared end of the hot power lead into the opening in the terminal block which is opposite of the empty terminal. Slide the bared end of the other hot or the neutral power lead into the middle opening of the terminal block. Tighten the screws firmly to hold the wires in place.

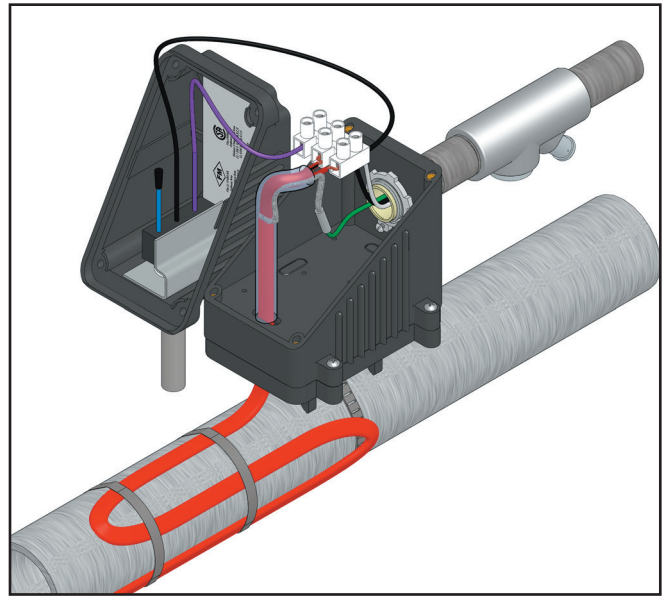

10. A. Slide the bared end of the black (NORMALLY CLOSED) thermostat wire into the opening of the terminal block which is next to the incoming power leads.  
 B. Slide the bared end of the purple (COMMON) thermostat wire into the opening opposite of the hot power lead. Tighten the screws firmly to hold the wires in place.  
 C. Trim the (NORMALLY OPEN) thermostat wire so that it is only 2" long. Tape over the end of the wire using fiberglass tape.  
 D. Slide the bared end of the ground wire into the end of the uninsulated barrel connector (Item 5). Crimp it on using a crimping tool. Slide the end of the braid pigtail into the other end of the uninsulated barrel connector and crimp it on. See wiring diagram on page 7.

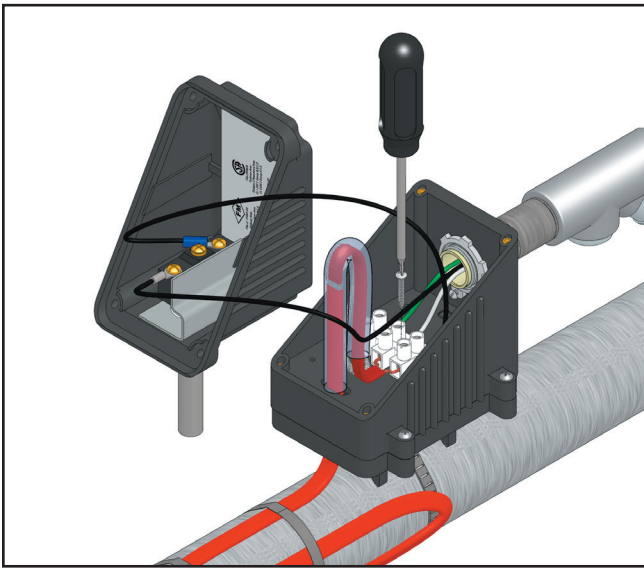

**11.** Mount terminal block to bottom of the box by driving the self-tapping screw (Item 11) provided into the mounting hole as shown.

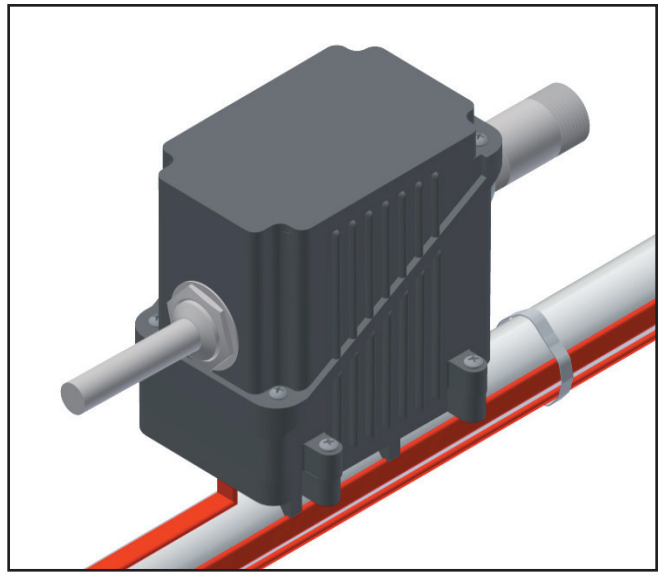

**12.** Carefully push all the wires into the box and secure the lid to the box. The thermostat is shipped factory preset and pre-calibrated for 40°F operation. The setting may be changed by rotating the white knobs until the desired temperature is directly behind the setting post.

# Wiring Diagram

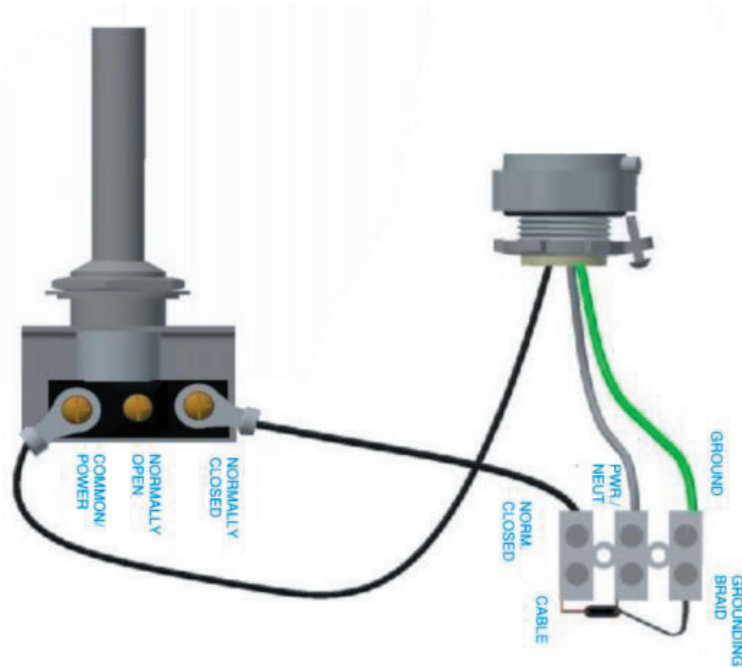
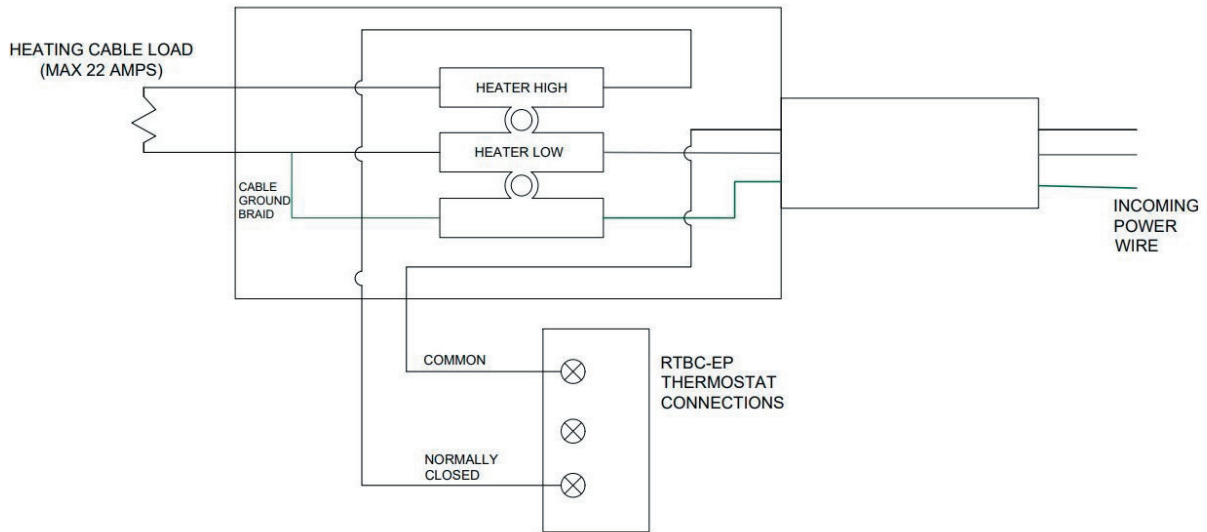

### Limited Warranty:

Please refer to the Chromalox limited warranty applicable to this product at [http://www.chromalox.com/customer-service/policies/terms\\_of\\_sale.aspx](http://www.chromalox.com/customer-service/policies/terms_of_sale.aspx).

**Chromalox, Inc.**  
**1347 Heil Quaker Boulevard**  
**Lavergne, TN 37086**  
**(615) 793-3900**  
**www.chromalox.com**