

Installation Instructions

UMC-LL Power Connection Kit

for Series Long Line Heating Cables

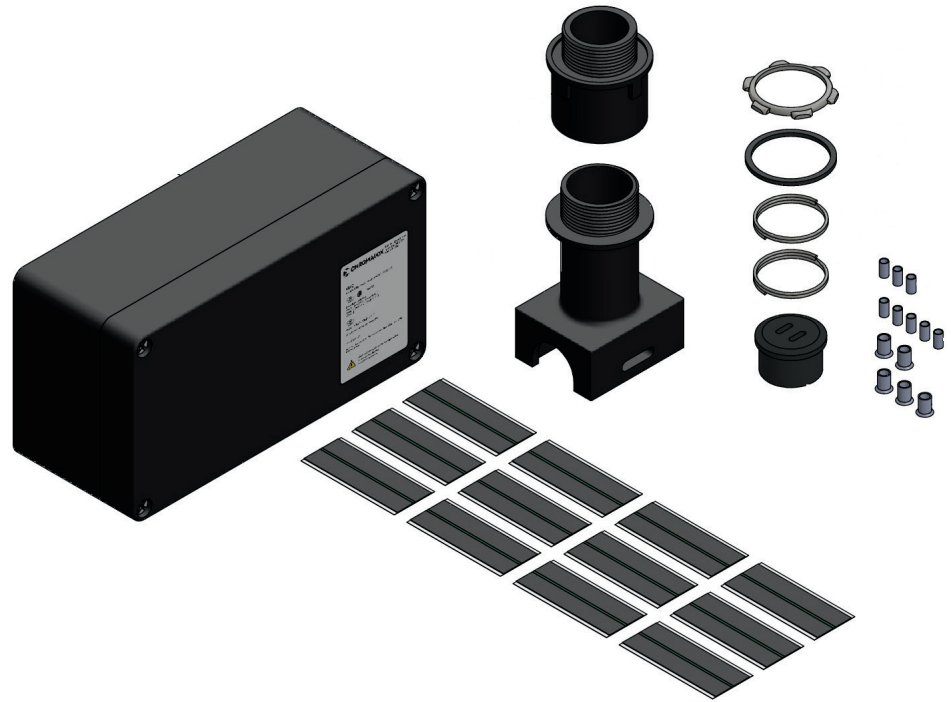

PJ949
161-562681-021
July 2015

UMC-LL End Termination Kit

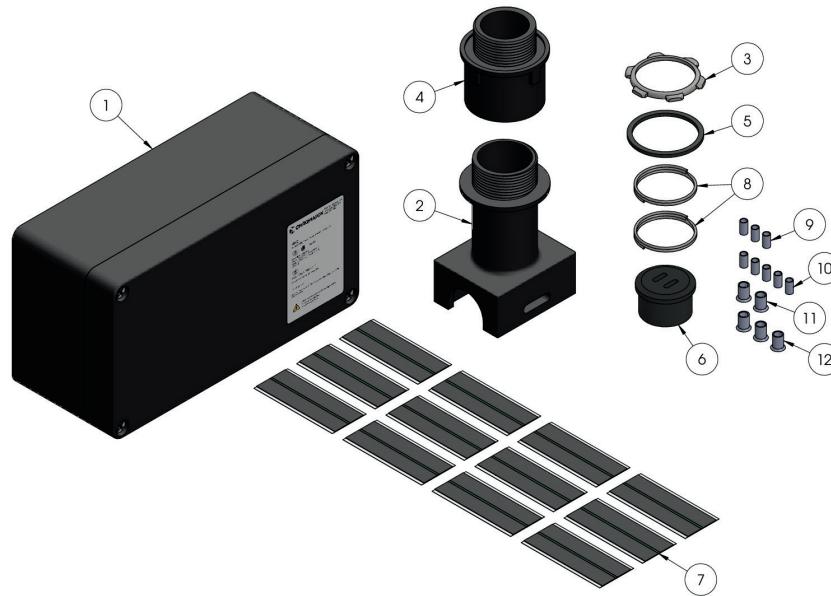

Kit Contents

Item	Qty	Description	Item	Qty	Description
1	1	Junction Box	7	12	Tape Strips
2	1	Pipe Standoff	8	2	Solder
3	1	Locknut	9	3	SLL 45 (B14-PS-M)
4	1	Compression Fitting	10	2	SLL 28/18 (C10-PS-D)
5	1	O-Ring	11	3	SLL 45/28/18/10 Ground Crimps (54610)
6	1	Self-Regulating Cable Grommet	12	3	SLL 10 Crimps (54615)

The UMC-LL power connection kit is used for electrical termination of two series long line cables. Each kit contains the terminations needed to make all electrical connections.

Tools Required for Kit Installation



Order Separately

Pipe Straps

- PS - 1 (382352) - 1/2" to 3/4" pipes
- PS - 3 (382360) - 1" to 3-1/2" pipes
- PS - 10 (382379) - 2-1/2" to 9" pipes



Caution Label CL-1 (382424) Fiberglass Tape FT-3 (389941)



Actual Kit Dimensions

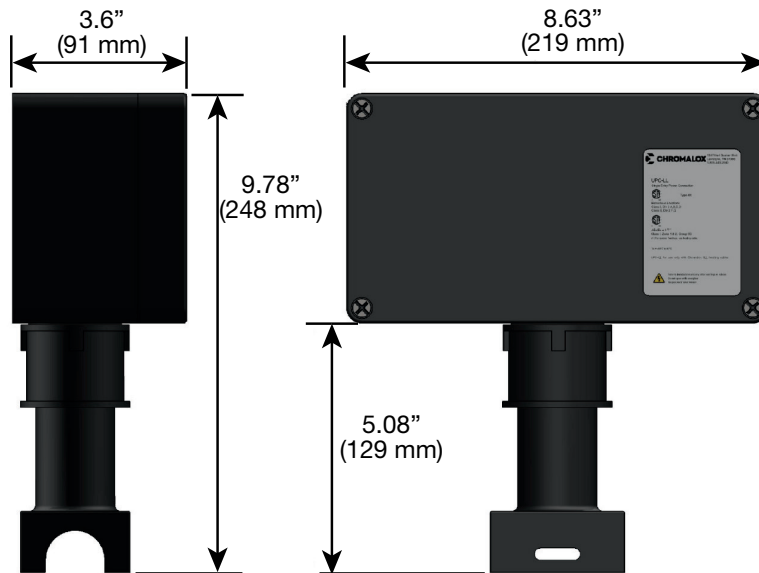

UMC-LL Cable Installation Instructions

⚠ WARNING

HAZARD OF ELECTRIC SHOCK. Disconnect all power before starting. All installations must be effectively grounded in accordance with the National Electrical Code to eliminate shock hazard.

⚠ WARNING

Turn off power before removing junction box cover at all times.

⚠ WARNING

Users should install adequate controls and safety devices with their electric heating equipment. Where the consequences of failure may be severe, back-up controls are essential. Although the safety of the installation is responsibility of the user, Chromalox will be glad to assist in making equipment recommendations.

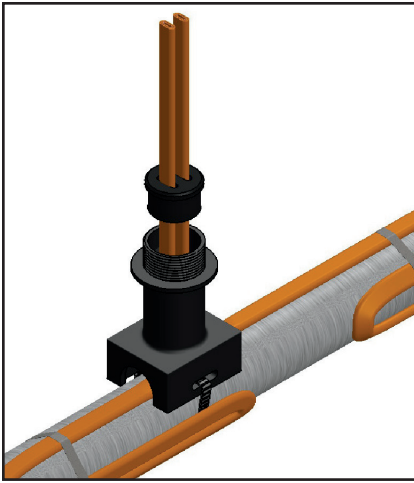

1. Insert heating cable through pipe standoff and grommet as shown. 7 inches of cable should extend past the grommet. Strap pipe standoff to pipe with pipe strap (Chromalox type PS not included) and attach extra cable to pipe as appropriate. For pipes smaller than 1 1/2" diameter a small pipe adapter (Chromalox model SPA not included) is required.

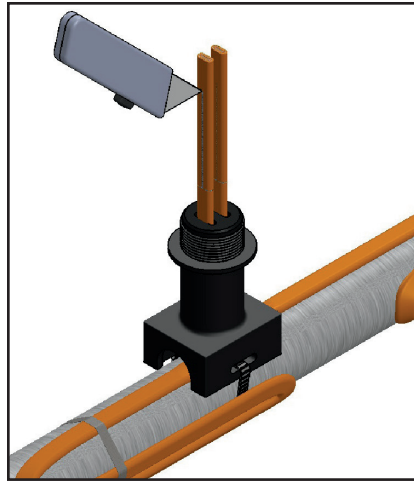

2. Score the outer insulation 6 inches from the end of the cable. Lightly cut the outer jacket up the center to the end of heating cable and remove the outer jacket from the cable.

WARNING: DO NOT CUT METAL BRAID.

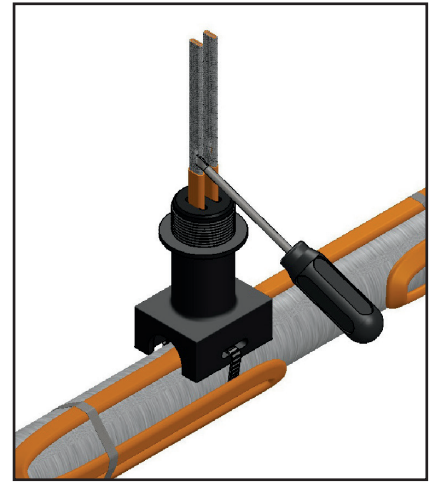

3. Move braid back toward the overjacket, creating a bulge. At the bulge, separate the braid to make an opening.

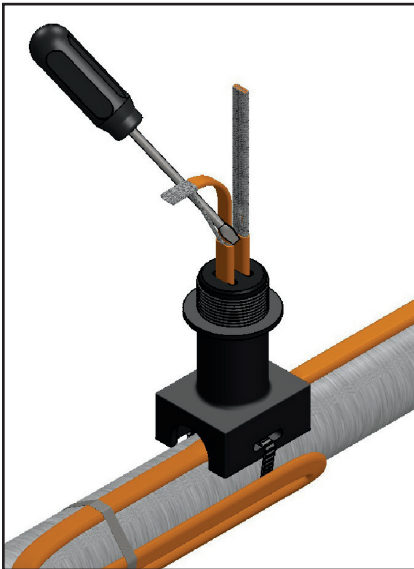

4. While bending the heating cable, work the cable through the braid opening. Pull the braid tight.

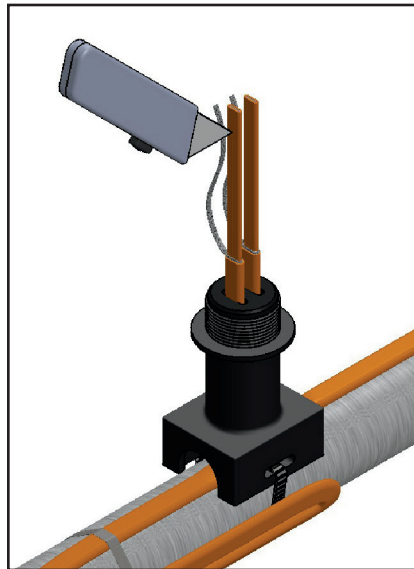

5. Score the inner insulation 5 inches from the end. Lightly cut the inner jacket up the center to end of heating cable and remove the inner jacket from the cable. Repeat on second cable.

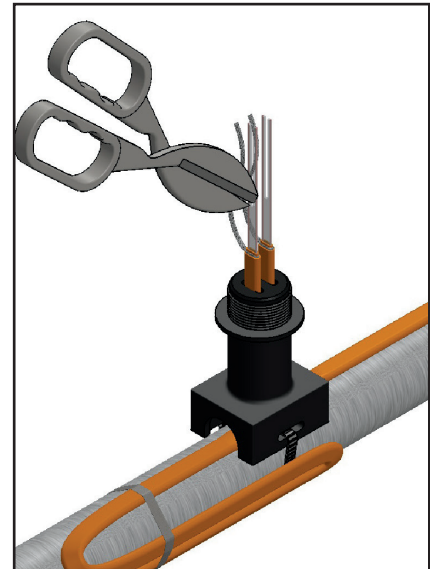

6. Use tin snips or similar tool to cut down the middle of the clear insulating material between the two buss wires. Repeat on second cable.

WARNING: DO NOT EXPOSE BUSS WIRES.

7. Remove 3/4" of insulation from each end of the conductor. Repeat on second cable.

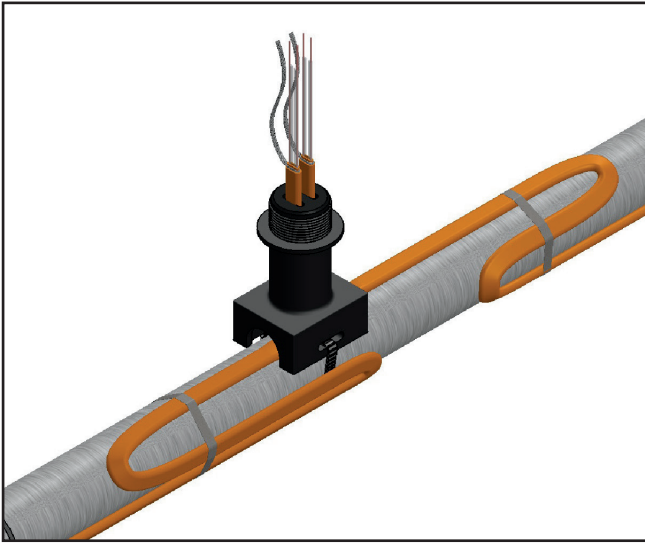

8. Slide compression fitting over cable. Grommet should be placed inside pipe standoff. Termination boot should be spaced 1/2" from sealing grommet.

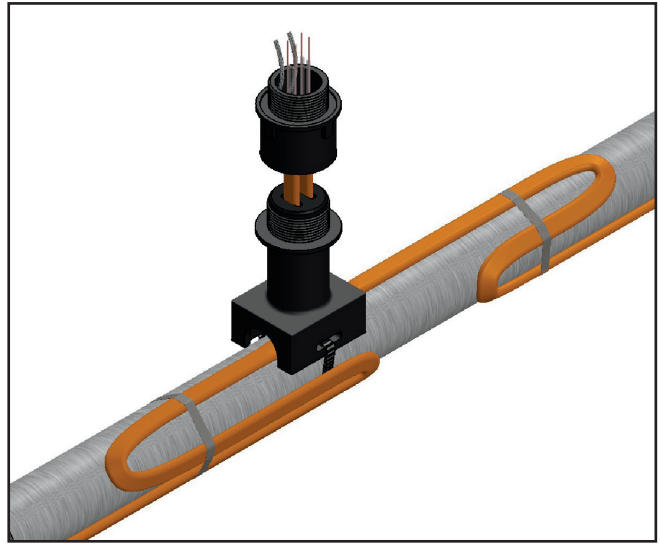

9. Assemble junction box to compression fitting as shown. Tighten locknut until the junction box bottoms out against the lip of the compression fitting.

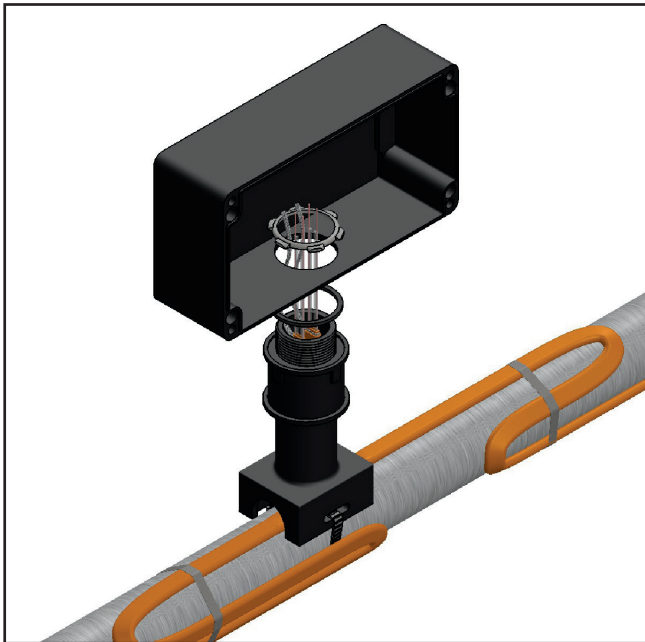

10. Crimp the cold leads to the buss wires as shown. Use the table below and only use recommended splice, crimp tool, and die to ensure proper electrical connections are made.

WARNING: IMPROPER CRIMP CONNECTIONS CAN RESULT IN OVERHEATING.

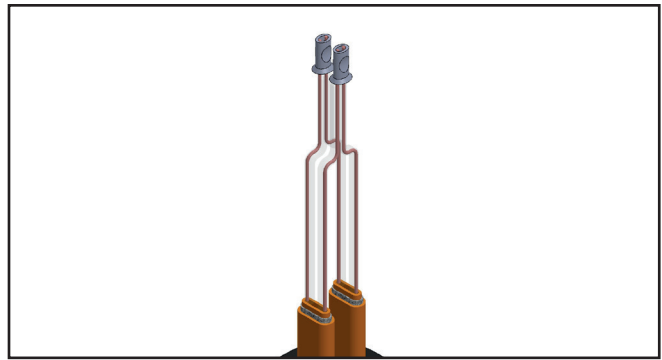

Cable Model	Wire AWG	Splice Model No.	Splice Color	Crimp Tool Recommended	Crimp Tool Die Color/Letter
SLL 45-CT	16	B14-PS-M	Silver (small)	ERG4002	B
SLL 28-CT	14	C10-PS-D	Silver (large)	ERG4002	C
SLL 18-CT	12	C10-PS-D	Silver (large)	ERG4002	C
SLL 10-CT	10	54615	Grey	TBM5S	Green

11. Crimp the braid wire to the green ground lead as shown. Use the table below and only use recommended splice, crimp tool, and die to ensure proper electrical connections are made.

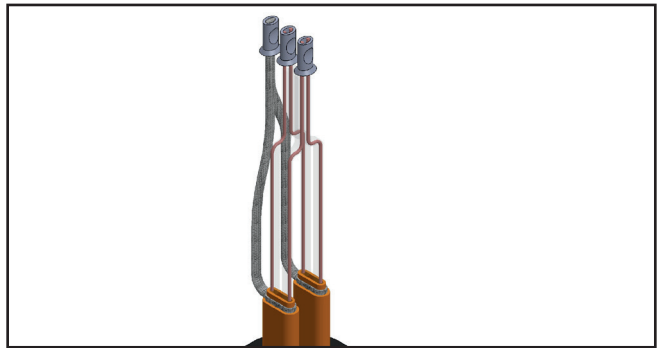

Cable Model	Wire AWG	Ground Crimp	Splice Color	Crimp Tool Recommended	Crimp Tool Die Color/Letter
SLL 45-CT	16	54610	Blue	TBM5S	Blue
SLL 28-CT	14	54610	Silver	TBM5S	Blue
SLL 18-CT	12	54610	Green	TBM5S	Blue
SLL 10-CT	10	54610	Green	TBM5S	Blue

12. Trim any excess wire so all wires are even with the top of the splice. Heat each splice using a soldering tool, propane or MAPP gas torch. Heat the center of the splice until it is hot enough to melt the solder placed at both ends. Allow splices to cool for several minutes before proceeding to the next step of wrapping the connection with tape.

WARNING: USE ONLY THE SOLDER PROVIDED WITH THE KIT.

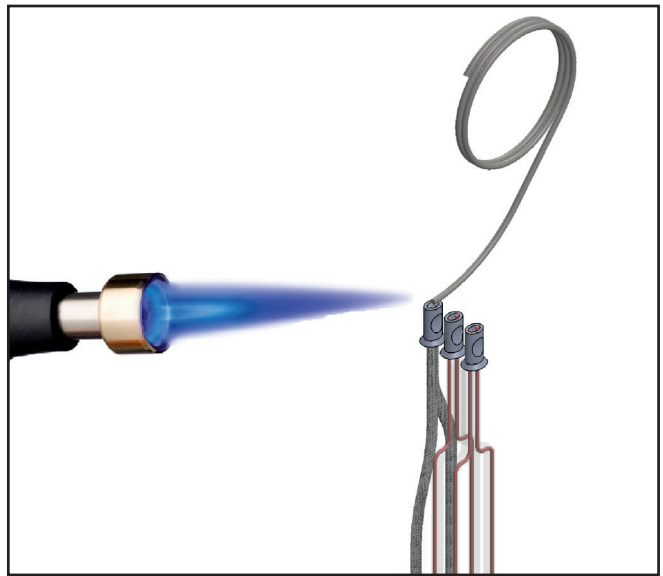

13. Fig. 1 - Wrap 1 strip of provided tape around the end of the splice as shown and push open end of tape together. Fold the top part of tape over as shown in Fig. 2.

Fig. 3 - Wrap the 2nd tape over the top of the fold piece of strip 1, then wrap it around the splice as shown.

Fig. 4 - Wrap the 3rd tape strip around the bottom portion of the splice so that it covers any exposed conductors and splice.

Fig. 5 - Wrap the 4th tape strip on the top part of the splice so that it covers at least 50% of the 3rd tape strip. Repeat Steps 1-4 for each connection.

WARNING: ONLY USE TAPE SUPPLIED WITH THIS KIT

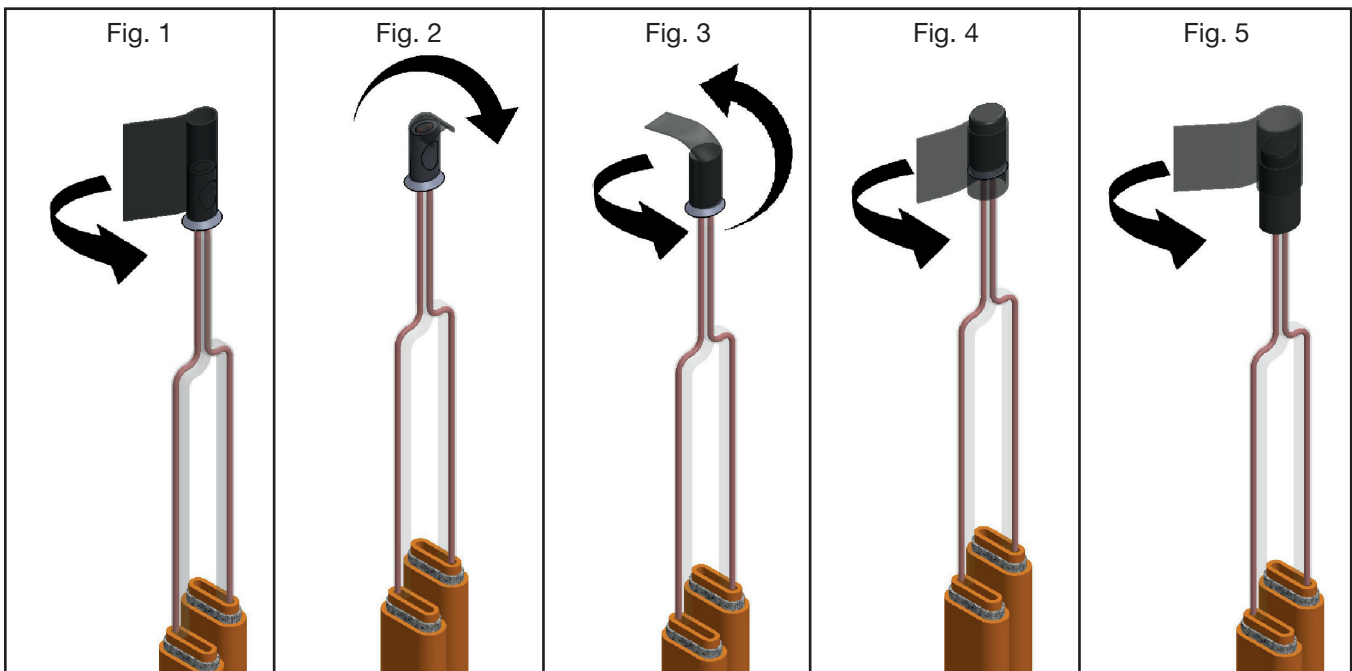

14. Place connections in box as shown with a minimum space between conductors of 5/16" (16 mm).

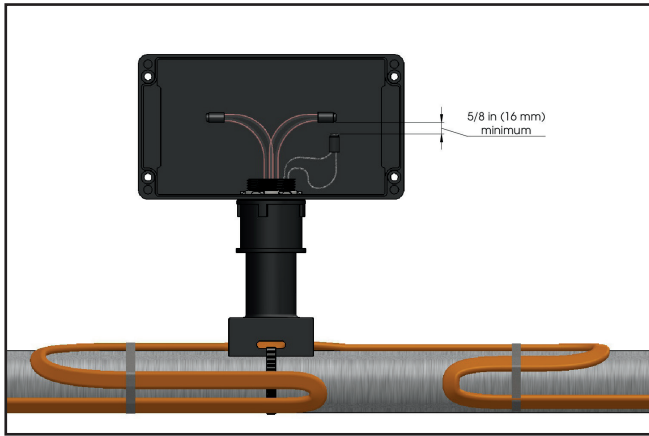

16. Place the lid onto the box and secure the lid by tightly fastening four screws.



Limited Warranty:

Please refer to the Chromalox limited warranty applicable to this product at <http://www.chromalox.com/customer-service/policies/termsofsale.aspx>.

Chromalox, Inc.
1347 Heil Quaker Boulevard
Lavergne, TN 37086
(615) 793-3900
www.chromalox.com