

Installation Instructions

USL Signal Light Kit

for Self-Regulating Constant Wattage Heating Cables



PJ937-1
161-562581-032
February, 2026

USL Signal Light Kit

Self-Regulating & Constant Wattage Heating Cable Installation Instructions

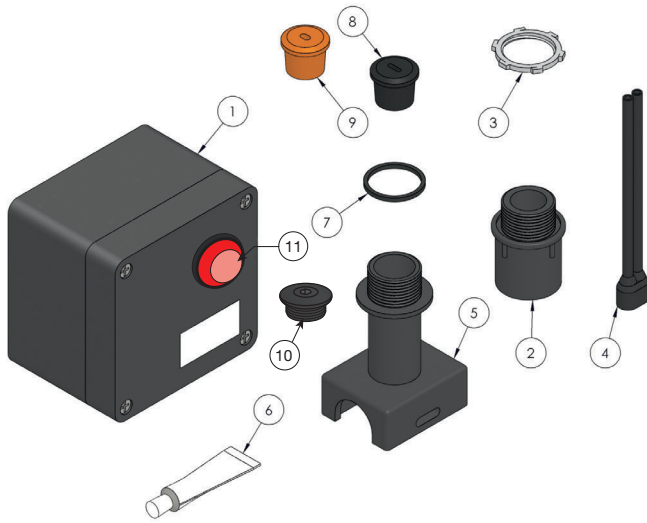

Item	Qty	Description
1	1	Junction box
2	1	Compression fitting
3	1	Locknut
4	1	Silicone termination boot
5	1	Pipe standoff
6	1	RTV
7	1	O-Ring
8	1	Self-regulating cable grommet (Black)
9	1	Constant wattage cable grommet (Orange)
10	1	Conduit Plug
11	1	Signal Light

General

The USL signal light kit is used for electrical termination of self regulating and constant wattage cables. Each kit contains the terminations needed to make all electrical connections.

Certifications & Approvals

IP66 NEMA/Type 4X -60°C < Ta < +55°C
Ordinary Areas

Tools Required for Kit Installation



Actual Kit Dimensions

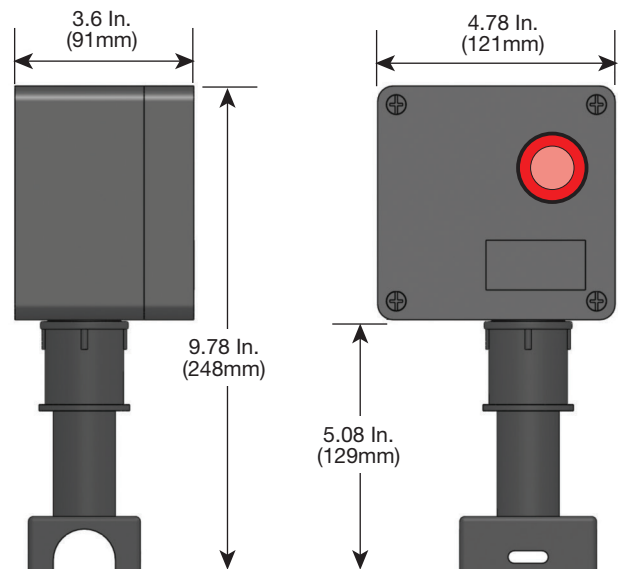

⚠ WARNING

HAZARD OF ELECTRIC SHOCK. Disconnect all power before opening. All installations must be effectively grounded in accordance with the National Electrical Code to eliminate shock hazard. To avoid electrostatic discharge. Wipe with damp cloth.

⚠ WARNING

Turn off power before removing junction box cover at all times.

⚠ WARNING

Users should install adequate controls and safety devices with their electric heating equipment. Where the consequences of failure may be severe, back-up controls are essential. Although the safety of the installation is responsibility of the user, Chromalox will be glad to assist in making equipment recommendations.

Order Separately

Pipe Straps

- PS - 1 (382352) - 1/2" to 3/4" pipes
- PS - 3 (382360) - 1" to 3-1/2" pipes
- PS - 10 (382379) - 2-1/2" to 9" pipes



Caution Label CL-1 (382424)

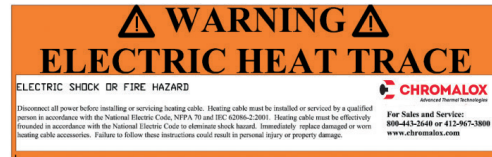

Fiberglass Tape FT-3 (389941)



SPA - Small Pipe Adapter (393609)

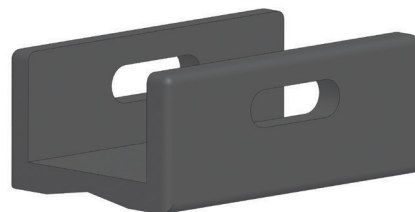

Cable installation instructions: SRL, SRF, SRM/E, SRP, SRH600
CWM cable special instructions denoted by

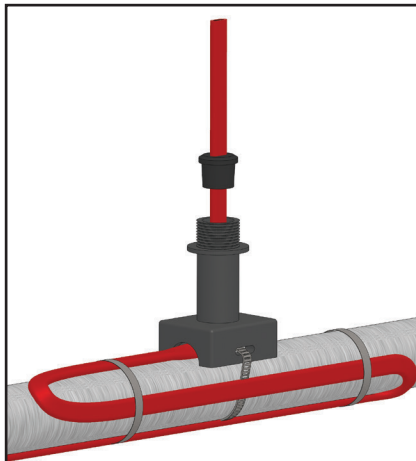

1. Insert heating cable through pipe standoff and grommet as shown. 8 inches of cable should extend past the grommet. Strap pipe standoff to pipe with pipe strap (Chromalox type PS not included) and attach extra cable to pipe as appropriate. For pipes smaller than 1-1/2" diameter a small pipe adapter (Chromalox model SPA not included) is required.

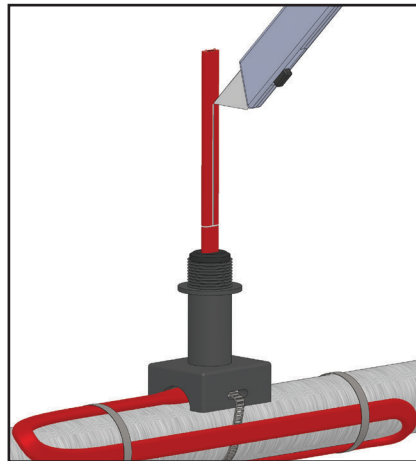

2. Score the outer insulation 7 inches from the end of the cable. Lightly cut the outer jacket up the center to the end of heating cable and remove the outer jacket from the cable. **WARNING: DO NOT CUT METAL BRAID.**

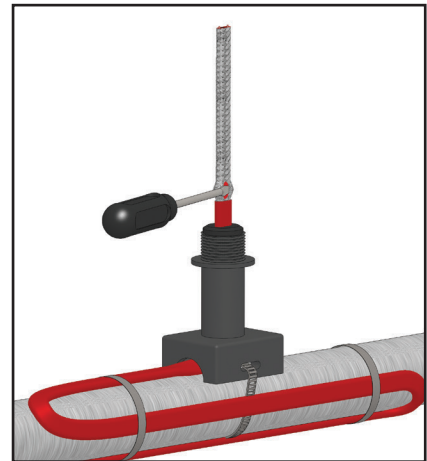

3. Move braid back toward the overjacket, creating a bulge. At the bulge, separate the braid to make an opening.

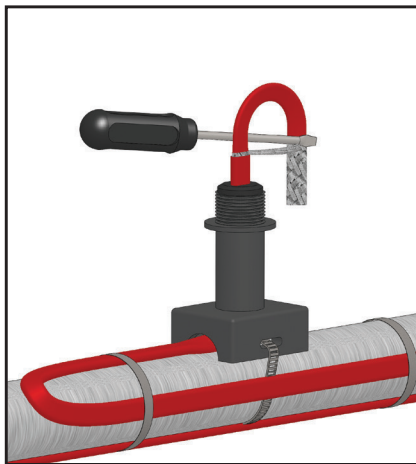

4. While bending the heating cable, work the cable through the braid opening. Pull the braid tight.

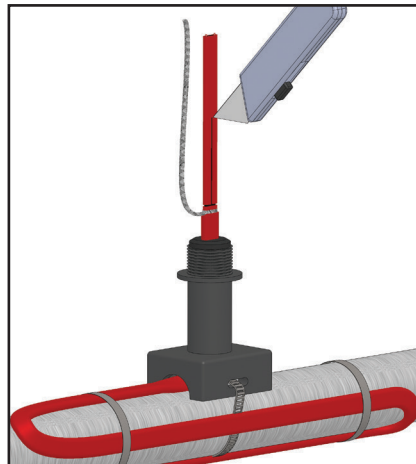

5. Score the inner insulation 6 inches from the end. Lightly cut the inner jacket up the center to end of heating cable and remove the inner jacket from the cable.

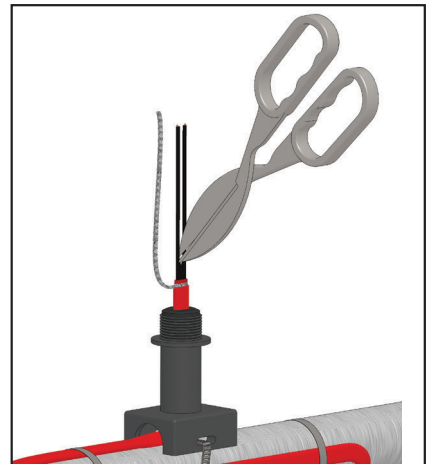

6. Use tin snips or similar tool to cut excess material from between the buss wires.
 *Separate CWM leads

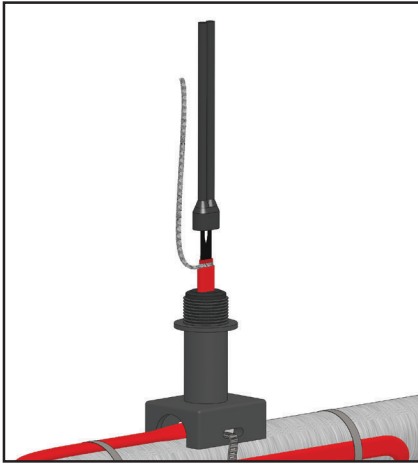

7. Liberally apply RTV over the exposed matrix and leads. Push the rubber boot over the heating cable.

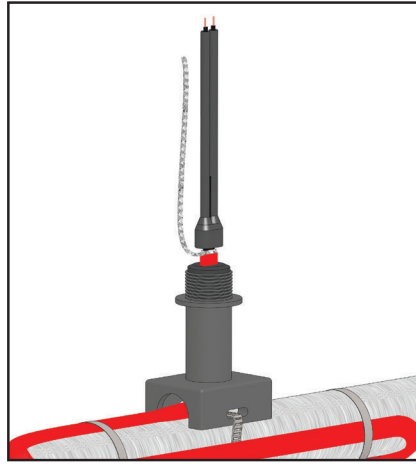

8. Strip each bus wire so that no black matrix material shows above the end of the rubber boot. Trim lead ends as needed.

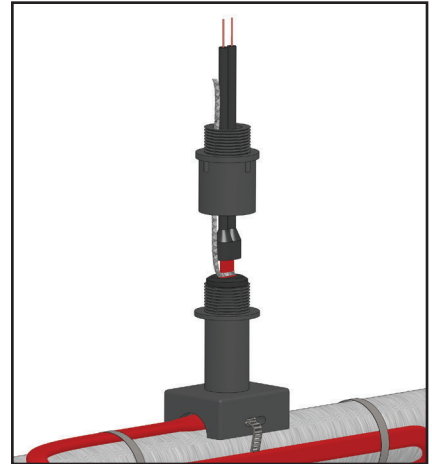

9. Slide compression fitting over cable. Grommet should be placed inside pipe stand-off. Termination boot should be spaced 1/2" from sealing grommet.

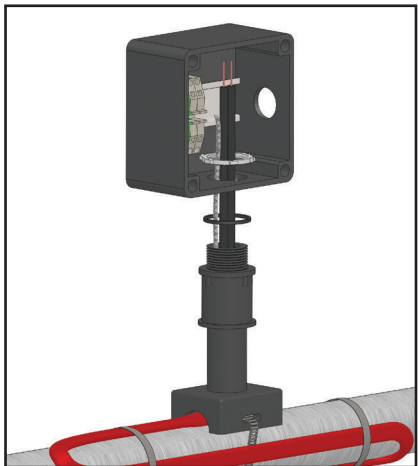

10. Assemble junction box to compression fitting as shown. Tighten locknut until the junction box bottoms out against the lip of the compression fitting.

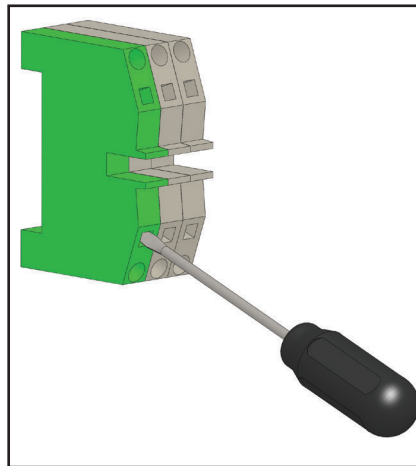

11. Attach 3/4" conduit hub. Use a flathead screwdriver to release the terminal spring clamps and insert cable leads and grounding braid as per wiring diagram on next page. Supply power electrical connections to terminals as shown on wiring diagram on next page.

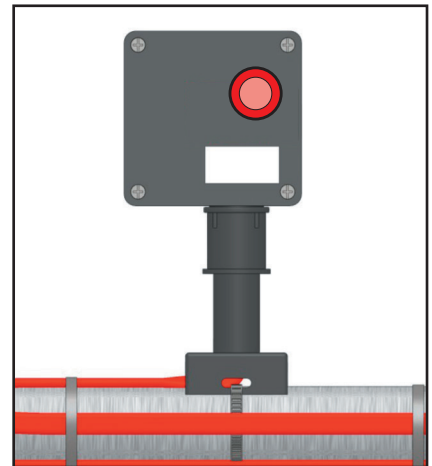

12. Once Locknut is secure and wires are secured in terminal, place cover on box and secure the lid to the box by tightly fastening screws.

Wiring Diagrams

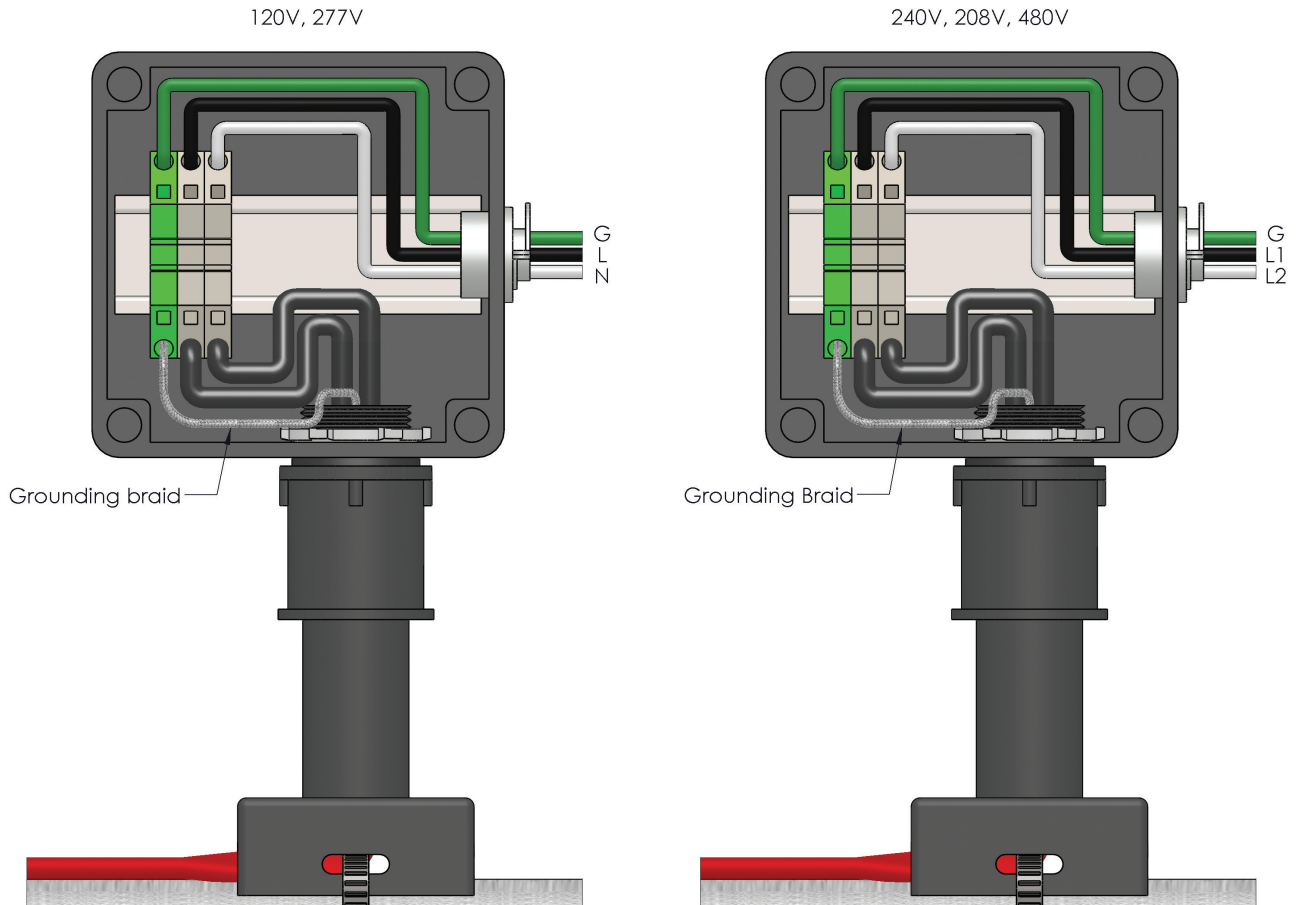

Limited Warranty:

Please refer to the Chromalox limited warranty applicable to this product at <http://www.chromalox.com/customer-service/policies/termsosale.aspx>.

Chromalox, Inc.
1347 Heil Quaker Boulevard
Lavergne, TN 37086
(615) 793
www.chromalox.com