

# Installation & Operation Manual

## Model CCX Cast Circulation Heater



 **CHROMALOX**  
*Advanced Thermal Technologies*

PE442  
161-307306-001  
March 2017

# Table of Contents

<b>Contents</b>	<b>Page Number</b>
Scope .....	3
Precautions & Warning .....	4
General Product Overview .....	6
Receiving, Handling, & Lifting .....	7
Inspection & Storage .....	8
Site Preparation & Heater Design Considerations .....	9
Installation – General .....	10
Installation – Mechanical .....	11
Installation – Electrical .....	12
Installation – Hazardous Area and/or Classified Location .....	13
Installation – Sensors and Power Control .....	14
Commissioning .....	14
Operation .....	15
Maintenance .....	15
Fault Finding & Correction .....	17
Health & Safety Statements .....	18
Service & Replacement Parts .....	18
Warranty .....	18
Appendix .....	19

# Scope

These guidelines are provided to assist in the handling, storage, installation and maintenance for a Chromalox CCX unit. Instructions are provided to prevent work site injury and aid in the handling, installation and commissioning of this equipment. If the CCX is being installed with a Chromalox control panel, please refer to the panel instruction manual for its proper instructions.

It is the responsibility of the site user to fully read and understand this manual prior to performing any work in conjunction with Chromalox equipment.

It is the responsibility of the purchaser of the equipment to ensure that safe systems of work are adopted for all personnel operating and maintaining the equipment including testing.

It is a warranty requirement to comply with these instructions and documented evidence shall be maintained in the form of a signed checklist as per the Appendix A or operator's equivalent.

**Note:** A completed Maintenance Checklist or equivalent will be required in the event of any safety or warranty claim.

Chromalox has a team of fully trained technicians and engineers who are able to offer a specialist inspection, commissioning, start-up and/or maintenance service. For further details, please contact our customer service department at 1-800-443-2640

# Precautions & Warnings

## General Equipment Warnings

The user must ensure that their employees are fully trained and supervised in the proper working procedures in order to ensure their safety. The plant must be maintained in a safe condition.

Personnel must be fully aware of the risk associated with electricity and hazardous area usage. Only qualified personnel shall perform work on this unit during installation, operation, and maintenance procedures.

This equipment was specifically designed for its intended purpose and shall not be used for any other application without a complete re-evaluation by the manufacturer. The operator shall ensure these instructions are kept with the equipment to prevent any misuse for which the equipment has not been designed.

The Safety Alert Symbol  is found throughout this document to identify potential hazards that if not avoided can result in personal injury. The seriousness of the potential hazard is identified by one of three signal words.

 **DANGER** – will result in serious injury or death.

 **WARNING** – could result in serious injury or death.

 **CAUTION** – may result in minor or moderate injury.

## Electrical Safety

### **⚠ WARNING**

**ELECTRIC SHOCK HAZARD. Disconnect all power before installing or servicing heater. Heater must be installed or serviced by a qualified person. Failure to do so could result in personal injury or property damage.**

All personnel working on electrical equipment shall strictly adhere to the applicable local, countrywide, and industry-recognized standards. Examples of such standards may include, but not limited to, the IEC (International Electric Code), NEC (National Electric Code), OSHA (Occupational Safety and Health Administration), NFPA (National Fire Protection Association), Health and Safety Work Act 1974, Factories Act 1961, and others. Failure to adhere to proper safety standards, including proper use of PPE (Personal Protective Equipment) may result in injury or even death. Chromalox will not be liable for failure of customer to adhere to governing standards.

 De-energize all equipment before opening junction boxes and control panels and follow the appropriate lockout / tagout procedures. Do not work on live circuits. Qualified persons and associated equipment must be effectively grounded in accordance with the applicable governing standard, such as the IEC (International Electric Code) to eliminate shock hazard. During any service work, please follow the proper electrical isolation, lockout / tagout, and disconnection procedures.

## Pressure & Explosion Warnings

### **⚠ WARNING**

**EXPLOSION HAZARD. When heating in closed vessels, controls and back-up controls must be used to regulate build-up of temperature and/or pressure. Failure to do so could result in personal injury or property damage.**

Before contemplating fill/pressurization, discharge or disconnection, the Installation, operation, and maintenance instructions must be read fully. The equipment is not to be disassembled while under pressure or vacuum. The operator must provide devices to prevent physical access whilst pressure or a vacuum exists.

The system owner must provide adequate means of draining and venting of pressure from equipment. The system owner must make provision to ensure proper sealing and pressurization integrity at all connection points.

The system owner must provide for suitable pressure relief measures and procedures to avoid dangerous discharge of pressure relief blow off and to protect against exceeding the vessel maximum design pressure. The operator must ensure that momentary pressure surges be kept to 10% of maximum allowable pressure.

Pressurization of the system shall be gradually applied, if possible, in order to allow for pressure connection integrity and minimize risk in the event of improper sealing of connections.

## Temperature & Combustion Warnings

The system owner must provide devices and warnings to prevent physical contact of personnel with hot surfaces.

### **⚠ WARNING**

**Since heaters are capable of developing high temperatures, extreme care should be taken to provide adequate spacing between hot surfaces and combustibles. Avoid operation of heater near combustible fluids or combustible gas laden atmospheres. Failure to do so could result in personal injury or property damage.**

The heater should be installed with over temperature protection and process flow interlock devices. These devices must be connected to the appropriate alarm / shutdown devices in the control panel. These safety systems must be tested and their correct operation verified prior to applying power to the heater.

Minimum designed flow must be maintained through the heater before energizing.

The heater shall be allowed to cool off to approximately 35-90°F (20-50°C) prior to the elimination of flow through the system in order to eliminate the risk of over temperature due to latent heat in the elements/system. Where necessary, the system owner must provide means of safe removal of residual heat after shutdown.

The system owner must ensure that steps are taken to avoid a dangerous accumulation of ignitable mixtures of combustible substance that could result in explosion or fire. Where necessary, the system owner must provide for sampling of the vessel from time to time to allow evaluation of the properties of the fluid so as to avoid risks related to deposits and/or corrosion.

Where necessary, the system owner must provide suitable accessories to meet damage-limitation requirements in the event of external fire.

# General Product Overview

The Chromalox CCX Heater is a thoroughly engineered unit, designed to give years of service, virtually maintenance free, if properly installed and operated. It is constructed for tough industrial applications such as offshore environments and or process critical needs.

The CCX unit can operate at up to 3500 psi (241 bar) at 392°F (200°C), with an optional feature allowing pressure of up to 7500 psi (517 bar).

The alloy heating elements are encased in an aluminum cast enclosure to provide heat transfer in a temperature controlled environment. Three temperature sensors are provided for monitoring temperature.

The E4 housing option is rated for moisture resistance, while the E2 housing is rated by both IEC and ATEX for Group II, Zone 1 environments. The heavy-wall process piping is rated by ASME and PED for continuous, high-pressure applications with butt-weld end connections.

Product specifications can vary depending on model. Equipment model and part numbers are located on a nameplate, typically located on the body/shell or enclosure of heater. Upon receiving equipment, take note of model and part number and document in appendix A.

## E4 Moisture Resistant Housing

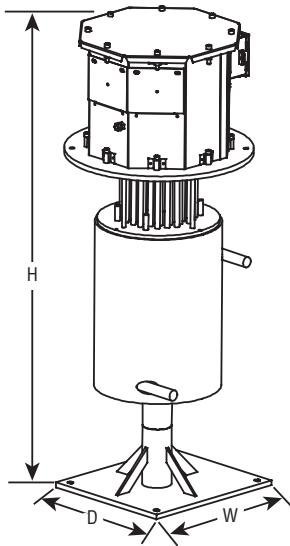

## E2 Hazardous Area Housing

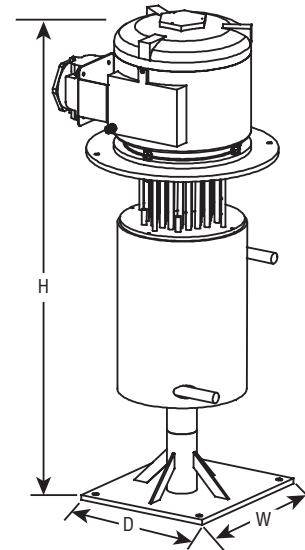

## Model Proportions

Units	Design Pressure	Temp Rating (T3)	Weight**	Width**	Depth*	Height**	Inlet/Outlet Connections	Piping Volume
Imperial	3500/7500 psi	392°F	550 lbs.	16"	14"	50-3/8"	3/4" ANSI	36.5 in <sup>3</sup>
Metric	241/517 bar	200°C	250 kg	40.6 cm	35.6 cm	128 cm	3/4" ANSI	598 cm <sup>3</sup>

\* For wall/horizontal mounting bracket, depth will increase to 18-3/4" (47.6 cm)

\*\* For 31-60 kW, weight is 800 lbs (363 kg.) and height will be 59-3/8" (150.8 cm)

# Receiving, Handling, & Lifting



The packaging supplied is only suitable for short term storage. The unit must be handled with care and stored in clean, dry conditions as befits any electrical apparatus. Units must not be exposed to wet or damp atmospheres. Units shall be stored in areas with uniform temperature control to prevent condensation accumulation.

Heater equipment shall be unpacked within 48 hours of receipt for proper inspection.

## **Unpacking**

The following steps shall be followed for unpacking:

### **Cardboard Packaging**

All staples to be removed with extractor tool only. Open cardboard flaps and remove heater from packaging. Remove any polythene covering using sharp knife, taking care not to damage equipment or paintwork with knife blade.

### **Wood Crating**

All nails to be removed with nail extractor tool only.

Extract nails, remove batten, and remove lumber from each side individually. Be sure to secure equipment from each side after removing crating. The recommended order for panel removal is – top, side panel, front panel, opposite side panel, and rear panel.

Remove any plastic covering using a sharp knife, taking care not to damage equipment or paintwork.

### **Equipment Handling & Lifting**

Ensure that the equipment is correctly moved and installed by technically qualified and competent persons experienced in the class of work involved. Know the capabilities of the lifting equipment available to handle the weight of the system.

Ensure that all precautions are taken regarding the weight of the heater. Lifting equipment shall have capacity for the given weight. Personnel involved in the installation need to be aware that one end of the heater will be heavier than the other and that this will affect the lifting.

Exercise care during any movement and placement operations to prevent falling or unintentional rolling or tipping.

Handle the systems with care to avoid damage to the heater electrical enclosure(s) and other protruding device(s).

If unit is equipped with skid framing, keep the system secured to the shipping skid to prevent distortion of the frame during moving and to minimize tipping.

If the heater equipment is a self-supporting item, equipment can be lifted from base utilizing lifting lugs or eyes placed as per the equipment drawing.

If the heater equipment is a flanged bundle assembly, extra care must be taken to prevent element damage during lifting and movement. Please refer to Appendix C for complete details.

Equipment can be moved by either crane or fork lift truck (preference should be given to crane handling whenever possible). Slings or ropes must be of good condition, showing no signs of fraying or damage. Using suitable lifting chains, ropes, or slings to prevent damage to the heating elements, observe the following safety points:

- All lifting tackle / equipment must have a safe working load (SWL) capacity in excess of that of the equipment weight and include for snatch factors etc.

- The slings or ropes must have sufficient length to keep the angle between the slings / ropes and the top of the equipment greater than 45°.

- Too short a sling / rope will reduce this angle and so lead to unacceptably high stresses on the eyebolts / lifting lugs.

- Certain equipment configurations may require a lifting beam to achieve a safe lift.

- Additional support should be provided, as necessary, when lifting, to counteract any out of balance that may be present.

- The swinging of the suspended load must be prevented and / or eased by suitable means.

- Forklift arms should be spaced as far as the configuration of the equipment allows and be long enough to go completely under the equipment.

- Move equipment by forklift truck only as far as is absolutely necessary, particularly at the assembly site and on uneven ground.

The destination needs to be free from obstructions. Ensure equipment is lowered gently to clean and level ground to prevent damage.

# Inspection & Storage

Each unit is manufactured with great care from the highest quality materials and thoroughly inspected before leaving the manufacturing facility. Examine the equipment against the packing list to check that the quantity received and its identity is complete.

Inspect the equipment/system to ensure no damage has occurred within 48 hours of receipt. If damaged, please report any claims to your carrier and contact Chromalox within 7 days for repair options. Do not attempt to operate damaged equipment.



Following inspection, units that are not going to be immediately installed and energized shall be properly stored to ensure no damage will occur from moisture accumulation. Units must be stored in clean, dry conditions as befits any electrical apparatus. Units must not be exposed to wet or damp atmospheres. Units shall be stored indoors in a heated area with uniform temperature control to prevent moisture accumulation

Units with anti-condensation heaters shall be powered, according to instructions.

Units without anti-condensation heaters shall have new desiccant packs installed in the terminal housing, according to volume size, with the housing shrink-wrapped in a moisture proof material.

For units that will be de-energized for a period of more than four weeks after receiving must be stored in accordance with Chromalox Long Term Storage Instructions – Refer to the Appendix Section B.

It is a warranty requirement to comply with these instructions and documented evidence shall be maintained in the form of a signed checklist as per the Appendix A or operator's equivalent.

**Note:** A completed Maintenance Checklist or equivalent will be required in the event of any safety or warranty claim.

# Site Preparation & Heater Design Considerations

The entire system should be clean prior to installation and starting up.

## Maintenance & Safety Considerations

Provide adequate space at the terminal end to permit proper access to terminal housing for installation and maintenance.

When positioning the heater, sufficient clearance shall be provided for the removal of the heater bundle from the installation, for servicing purposes. Be sure to consult local building codes for minimum distance for clearance, access, and personnel protection.

Provide adequate spacing from the chamber and related piping to nearest combustible material.

Do not operate heater near combustible fluids or in combustible vapor or gas laden atmosphere unless specifically designed for such conditions.

The use of insulation on the heating system is recommended to avoid excessive energy loss through exposed surfaces. Insulation shall be of such a type suitable for the temperature classification of the system. Closed cell insulation is recommended to avoid the absorption of any liquids that may be present in the area. Terminal enclosures are not part of the thermal process and **MUST NOT** be insulated. If a unit is equipped with standoff design, the around the standoff tubes **MUST NOT** be insulated. This area shall remain open to the surrounding air flow to allow for heat dissipation.

## Mounting, Connection, & Support Considerations

In a forced circulating system, the pump outlet should be connected to the heater inlet nozzle.

If using two or more heaters for an in-line application, they should be arranged in a series configuration.

For horizontal vessel installations, the heater inlet and outlet should be mounted in the upward facing plane to help prevent air pockets.

Unit should never be located at the highest point of a system due to the possible accumulation of air pockets.

For heater bundles in an exposed area, such as a tank, the elements can be protected from possible mechanical damage by placing a screen or grill around the elements.

When heating liquids in a large tank, the use of several small heaters will provide more uniform heat distribution than a single large heater.

For heater bundle installations, the bundle shall be supported if the immersion length is great than 36" (0.92 m). Recommended support is every 24" (0.61 m). External support shall be at the element spacer(s).

If not practical, element supports shall have a minimum width 2" (5 cm) so as to not deform the heating elements and shall provide a 180° circumferential support to the lower half of the bundle.

## Process Flow Considerations

Use of filters and/or strainers may be required where elements face exposure to materials other than that for which the heater is designed (particles, foreign matter, etc.). The process or maintenance supervisor should assess this thoroughly before installation, and ensure that filtering/straining provision is adequate. If provided, strainers and filters must be cleaned and inspected following the system commissioning.

Heater must only be operated in its intended process media. Buildup of sludge, minerals, or other deposits will reduce heater performance and life expectancy. Be sure the sheath material is compatible with the material being heated.

For liquid applications, be sure the liquid level will always be above the effective heated portion of the heater. If the heater is not properly submerged, it may overheat and damage the heating elements.

Do not allow heater to operate when flow is interrupted or when liquid levels will expose the heating elements. The installation should have level, flow, or pressure switches to ensure proper flow is maintain and to provide equipment and personnel protection.

On any pressurized or closed system, a pressure relief valve must be provided by the user. It is recommended to install one near the outlet of the heater. There shall be no other valves or other device to block flow between the vessel and relief valve. It is also highly recommended that proper primary and back-up control system be used to prevent the buildup of temperature and/or pressure.

Ensure the watt density of the heater is suitable for the material being heated. The velocity, viscosity, and thermal conductivity of the material and operating temperatures are all factors in determining the allowable watt density of the elements. Consult Chromalox if in doubt about the watt density of the unit for the application.

## Temperature Sensor Considerations

When using an element sheath sensor, be sure to install flange with the sensor in the top position. This is to ensure that any drop in liquid level will expose the sheath/sensor first. This position will also help in reading the highest internal sheath temperature due to rising heat.

# Installation - General

This section outlines the contractor's responsibility for the erection and installation of the equipment supplied.

The equipment shall be installed by the contractor under the surveillance of the client's site engineers, in accordance with these instructions.

The installation shall be carried out in complete accordance with this document, which shall be read as complimentary to all associated contract documents (such as site conditions, contract specifications and drawings) and national legislation / regulations.

The erection contractor shall ensure that their employees are fully trained and supervised in the appropriate site working procedures in order to ensure their safety. The site must be maintained in a safe condition at all times.

The erection contractor shall ensure that their site installation personnel are issued with copies of all relevant drawings, material schedules and specifications to enable them to fulfil their obligations.

The erection contractor shall be responsible for providing all tools and equipment necessary to carry out the installation as required on the schedule drawings.

General safety precautions listed in the plant Safety Manual shall be complied with to prevent injury to personnel or damage to equipment.

***This unit must be installed in accordance with all local codes. The local specifications and codes define the requirements of use for installation and operation of equipment in potentially hazardous atmospheres. The operator installing the heater must either be fully conversant with local specifications or have access to it to ensure the heater is correctly installed.***

Ensure that the area safety supervisor and others in the vicinity are aware that work is being undertaken and post warning notices. A Job Hazardous Analysis or Work Permit Review should be completed prior to installation. Ensure that the appropriate safety equipment and clothing is worn. Beware of wet or slippery ladder rungs and working areas if working aloft.

Any persons about to perform installation procedures with any electric heater must first satisfy themselves as to the nature and extent of any potential hazards that may be encountered. These hazards should be identified by a risk analysis undertaken by the responsible person within the installation team prior to commencement of the installation process.

Confirm all electrical power has been disconnected using properly calibrated metering or detection equipment. Lockout/tagout shall always be performed prior to entering electrical panels.

Main disconnect switch will typically lock and remove all power in a panel except for low level dc control circuits being input by the PLC (Programmable Logic Control) or DCS (Distributed Control System). Only qualified, trained electrical personal shall perform any activity on energized equipment.

Where work will pass over or near equipment, additional protections such as a metal guard may be needed.

Modifications made to the equipment during installation, other than those explicitly defined by Chromalox, are prohibited and will null and void warranty, and may cause injury to personnel and equipment.

It is a warranty requirement to comply with these instructions and documented evidence shall be maintained in the form of a signed checklist as per the Appendix A or operator's equivalent.

**Note:** A completed Maintenance Checklist or equivalent will be required in the event of any safety or warranty claim.

# Installation - Mechanical

Unit must be inspected before installation to ensure no damage has occurred during shipment, handling, or storage.

For flange bundle heaters, the installer shall confirm the correct orientation of the unit to design specifications. Items such as sensors, baffling, thermowells, or other position specific devices must be installed correctly. Take extra care to not bend the heating elements during installation. Refer to Appendix C for additional details.

Before installation, commissioning, and/or after long term storage, it is advisable that the elements be checked to ensure that the insulation readings are above 1 M $\Omega$  per element at 500 volts dc. If there is an unacceptable low reading on any of the elements, it will be necessary to dry them out. For the detailed procedure, please refer to the Appendix Section B.

Ensure the unit is properly certified for the intended site usage and area classification. Ensure that the equipment is appropriate to the surface temperature class and the heater temperature class is stamped on the terminal box label.

Unless specifically designed otherwise, the terminal box shall not be subjected to direct sunlight at ambient temperatures above 30°C. Unless specifically designed otherwise, the air surrounding the terminal enclosure shall not exceed the maximum design temperature of 40°C.

Circulation heater connection nozzles are not designed to support piping loads. The foundation must be sufficiently designed to prevent the heater from settling or heaving, which could cause the piping to transmit excessive strains to the heater nozzles. It is recommended that for concrete footings pipe sleeves should be fitted on each foundation bolt. These should be at least one size larger than the bolt diameter, as they allow the bolt center to be adjusted after the foundation has cured.

Mount circulation style heaters to permit unrestrained expansion of the chamber and inlets / outlets due to thermal expansion. This can be accomplished by using slotted mounting assembly in conjunction with the heater support members (mounting lugs, saddles, or other supports). Piping allowances must be made to allow expansion without putting stress on the heater nozzles.

The heater skid, supporting structure, or mounting lugs should be adequately protected against mechanical damage, extreme temperatures and other adverse conditions.

Heater should be adequately secured to avoid excessive vibration. Excessive vibration can result in increased wear on element sheath(s), cause erratic operation for unit mounted thermostats, and pre-mature loosening of proper torque specification on bolting and electrical connections.

The preferred method is to vertically mount the unit, with the terminal box at the bottom, to prevent excess temperatures with the electrical wiring. However, units can be vertically or horizontally mounted in accordance with third party standards or per Chromalox application specific designed drawings.

All heater openings and terminal housings shall be inspected for foreign material. Protective plugs, covers and desiccant shall not be removed until just prior to installation.

All gasket surfaces must be clean and dry before seated to mating equipment. When connecting flanged joints, only nuts, bolts and gaskets in accordance with the applicable piping specification shall be used and tightened to the recommended torque as specified in the piping specification. Refer to Appendix D for tightening guidelines.

All bolting should be re-checked during start-up to avoid leakage during operation.

# Installation - Electrical

## General

This unit must be installed in accordance all local electrical codes. The specific local specifications and codes define the code of practice for electrical apparatus for use in potentially hazardous atmospheres. The operator installing the heater must either be fully conversant with local specifications or have access to it to ensure the heater is correctly installed.

Any persons about to perform installation procedures with any electric heater must first satisfy themselves as to the nature and extent of any potential hazards that may be encountered. These hazards should be identified by a risk analysis undertaken by the responsible person within the installation team prior to commencement of the installation process.

Only qualified, trained electrical personnel shall perform any activity on energized equipment. Lockout / tagout shall always be performed prior to entering electrical panels. Main disconnect switch will lock and remove all power in the panel except very low level dc control circuits being input by the DCS.

## Heater Wiring / Cabling

### **⚠ WARNING**

***ELECTRIC SHOCK HAZARD Disconnect all power before installing or servicing heater. Heater must be installed or serviced by a qualified person. Heater must be effectively grounded in accordance with in accordance with the applicable governing standard, such as the IEC (International Electric Code). Failure to do so could result in personal injury or property damage.***

Refer to heater drawing to review unit voltage, circuits, phase, and kW rating. Check to ensure that the line voltage and phase is the same as that stamped on the nameplate. Verify wattage rating versus the requirements at the installation site.

Prior to wiring installation, check all bussing to element hardware is tightened to 14-17 in-lbs. (1.58-1.92 Nm). Check all remaining bussing to bussing hardware is tightened to 20-25 in-lbs. (2.26-2.82 Nm).

The heater should be protected by a suitable earth leakage protection system, with a maximum trip response time of 10 milliseconds, wired to signal alarms and shutdown the heater in the event of heating element failure to earth.

The terminal points for each heater are as follows: -  
Power terminals (entry through cable gland plates or conduit connections)

Equipment earth / ground terminals (internal and/or external)

Sensor and/or control terminals (entry through cable gland plate or conduit connections). Refer to Sensor Wiring section for further details

Ensure that the equipment is earthed in accordance with the plant grounding / earthing philosophy.

Power to Terminal ends of heater must be protected from drippings, condensation, spray, or direct spill over of material whose presence at the terminal may damage heater electrical insulation. Liquid tight enclosures, anti-condensation heaters, or other appropriate apparatus(s) should be used for proper operation, where needed.

## Wiring / Cabling Recommendations

Due to high operating temperature conditions, minimum of 250°C wire shall be used for terminal connection. Higher temperature cabling may be needed, based on process conditions. Please review terminal housing temperature classification to ensure proper compliance.

The current carrying capacity of the power supply leads shall exceed the heater amperage by at least 25%. Be sure to consider the ambient temperature, terminal box operating temperatures, and conduit loading factors to apply the appropriate correction factor to the ampacity rating of the wire. Sufficient space should be allowed for wire bending radius.

Electrical wiring should be contained in a rigid conduit or in a sealed flexible conduit when corrosive vapors or liquids are present. If high humidity or similar moisture conditions will be present, the conduit should slope down and away from the heater in a 'drip-loop' configuration with appropriate breather drains installed.

If flexible cord is used, as permitted by code, a water-tight connector should be used for entry of the cord into the terminal box. Outdoor applications require liquid-tight conduit and connectors.

To prevent moisture accumulation in cryogenic applications or when heater is exposed to freezing temperatures:

Slope conduit away from enclosure (drip loop).

Seal all conduit openings to moisture/explosion resistant terminal enclosure.

Externally insulate terminal enclosure.

Fill open thermowell(s) with silicone fluid when heater is mounted with terminal enclosure up.

# Installation - Hazardous and/or Classified Areas

Use only certified hazardous rated enclosures in hazardous location environments. The proper use of terminal enclosures on electric heaters located in hazardous areas requires that all electrical wiring comply with National Electrical Code (NEC) or International Electric Code (IEC) requirements for hazardous locations.

Due to the nature of hazardous area location installations, it is highly recommended the purchaser, user, and installer consult with those certified in such installations to ensure proper compliance.

## Maximum Temperatures

Safe operation in a hazardous location requires the maximum operating temperatures of all exposed surfaces of the heater including temperatures on the outside of the vessel, piping, flanges, screw plugs, enclosures and other heat conducting parts be limited. The flammable liquids, vapors or gases present determine the maximum surface temperature permitted in any hazardous location. The end user or purchaser of the electric heating equipment is responsible for determining the proper classification of an area and for providing Chromalox with hazardous area specifications and requirements for proper equipment design.

***The system owner must provide devices and warnings to prevent physical contact of personnel with hot surfaces.***

## **⚠ WARNING**

***Since heaters are capable of developing high temperatures, extreme care should be taken to provide adequate spacing between hot surfaces and combustibles. Avoid operation of heater near combustible fluids or combustible gas laden atmospheres. Failure to do so could result in personal injury or property damage.***

# Installation - Heater Sensors and Power Controls

Heater units may be equipped with a varying degree of temperature sensors and/ or controls. These components form part of more complex system installed at the site. It is the responsibility of the end user to ensure that all components are designed and installed properly to ensure safe operation.

Heating units will need to be regulated by a temperature and power control system. Please review the control system design and instructions with a certified professional for proper performance and safe usage.

Be sure to consult all appropriate manufacturers' instructions for proper system design and usage.

The user must ensure that safety interlocks are provided and maintained to so that the heater can only be energized when the design flow rate through the heater is present. Heater should be de-energized or have a de-rated power output, should this flow rate be reduced or stopped.

Separate wiring must be used for all process or high limit temperature sensors. Ensure longer runs use the appropriate extension wire and meet ground shielding requirements.

Below is a listing of typical sensors used in conjunction with heater units. This is not an all-inclusive list. If you are unsure of any operation, please consult with a certified professional.

**Process Sensor(s)** – This unit may contain a process sensor, such as a thermocouple or RTD. These

sensor(s) are meant to provide temperature feedback on the process stream to a dedicated temperature control system.

**Overtemperature Sensor(s)** – This unit may contain an overtemperature sensor, such as a thermocouple or RTD. These sensor(s) are meant to provide temperature feedback of the heating elements. These are typically used to prevent an overtemperature situation of the process heating elements. These sensors shall be wired to a dedicated safety shutdown control system.

**Thermostat(s)** – Thermostats are bulb and capillary type temperature sensors meant for general temperature sensing duty. Depending on the thermostat volts and amperage rating, thermostats will be wired in one of two configurations:

Load-carrying thermostats, capable of switching the heater load, may be wired in series with the heater power wiring to directly control heat input.

Pilot Duty thermostats must be used in conjunction with a properly sized contactor. The contactor must be installed external of the heater terminal housing and in accordance with the prevailing electrical code.

Always consult the specific ratings and manufacturer recommendations of the thermostat for complete details.

---

## Commissioning

Before installation, commissioning, and/or after long term storage, it is advisable that the elements be checked to ensure that the insulation readings are above 1 MΩ per element at 500 volts dc. If there is an unacceptable low reading on any of the elements, it will be necessary to dry them out. For the detailed procedure, please refer to the Maintenance section E.

Heater unit shall not be energized until all checks are complete. The terminal enclosure cover shall only be removed when there are no hazardous gases present.

Check overall physical condition of the heater for any signs of damage.

Installation layout should be neat in appearance.

Check for any loose components.

Remove all debris from enclosures.

Ensure that any preservation items such as VCI pads or dessicant bags are removed.

Ensure all bussing hardware is tightened per 'Installation' Section. Reconnect the wiring / cabling ensuring terminations are secure.

Ensure both heater and instrument enclosure covers are closed and all fastenings are tight.

Check that labels and tags are secure and correct.

Ensure the operating conditions for which the heater was designed are matching the actual process settings. Ensure the process flow is available

Ensure process media is not corrosive to the heating elements or chamber.

Ensure the process controller and overtemperature controller has the correct operating settings and is functioning properly.

Ensure all other safety and / or shutdown devices are functioning properly.

Check all piping connections are properly torqued. A system hydro-test is recommended to verify no leakage will occur in the system.

It is a warranty requirement to comply with these instructions and documented evidence shall be maintained in the form of a signed checklist as per the Appendix A or operator's equivalent.

**Note:** A completed Maintenance Checklist or equivalent will be required in the event of any safety or warranty claim.

# Operation

Before operating the equipment, the installation should be approved by a supervisor to ensure that the system is safe for operation with all commissioning checks completed.

**Low Megohm Condition** — The refractory material used in electric heaters may absorb moisture during transit, storage or when subject to humid environments that will reduce the insulation resistance (low megohm). Low megohm may result in high leakage current to ground and nuisance trips of ground fault protection equipment. Normally, the megohm value increases after heat-up. If persistent conditions persist, the heating elements may need to be dried out to remove moisture. Refer to Appendix E for details.

Do not operate heaters at voltages in excess of that stamped on the heater.

Ensure the overtemperature controller and / or other safety limit devices are set to the correct parameters.

Bleed the air out of the piping system and heater enclosure (for purged electrical systems) prior to energizing.

Set the process control device(s) to operating conditions. Do not set the process temperature above the

boiling point of any liquid. The boiling liquid could create a gas pocket which could cause the element(s) to overheat and burn out.

For some liquid application (such as oil), operating at high temperatures, any remaining water must first be purged from the system. Unit should be operated at approximately 220°F (105°C) to allow the moisture to flash to steam. Continue to bleed steam through bleed-off valves until all moisture is removed.

Energize power supply to the heater, allowing the process conditions to stabilize.

Check the temperature and adjust the control device(s) to achieve the required temperature.

It is a warranty requirement to comply with these instructions and documented evidence shall be maintained in the form of a signed checklist as per the Appendix A or operator's equivalent.

**Note:** A completed Maintenance Checklist or equivalent will be required in the event of any safety or warranty claim.

---

# Maintenance

No operation involving the use of an open flame or other source of ignition shall be attempted until the condition has been made safe (gas free) by the control of the flammable material that may give rise to the risk. Electrical test equipment can constitute a hazard and shall not be used in the presence of a flammable material, unless specifically designed for the purpose and suitably certified.

If installed heaters are not used for a period in excess of 3 months, they must be tested for insulation resistance. Low megohm may result in high leakage current to ground and nuisance trips of ground fault protection equipment. Normally, the megohm value increases after heat-up. If persistent conditions persist, the heating elements may need to be dried out to remove moisture. Refer to Appendix E for details.

Heaters shall be routinely checked and maintained to ensure sustainability. The following preventative maintenance shall be carried out at the intervals shown below. Chromalox service technicians are also available to assist in on-site work or personnel training.

## **Every 3 months**

Visual inspection of equipment for any external damage, wear, or leakage.

Lifting eyes and lugs must be regularly checked for corrosion and appropriate measures taken to remedy corrosion such that the integrity is not compromised.

The paint condition of the equipment must be checked periodically to ensure the corrosion allowance is not exceeded.

All electrical power connection, sensor connections, and mechanical bolting shall be re-torqued to proper specifications.

## **Every 6 months**

Isolate the electrical supply and remove the terminal enclosure cover. Do not remove the terminal enclosure cover during wet or humid conditions as this can lead to a reduction in insulation resistance of the heater. Ensure that internals are clean, dry and free from debris.

Ensure that all grounding / earthing conductors are correctly fitted between all points and main structure.

Visually inspect wire and wire terminations. Replace any which show signs of oxidation which would interfere with establishment of reliable electrical connections.

If corrosion is indicated in the terminal enclosure, check terminal enclosure gasket and replace if necessary. Check conduit layout to correct conditions that allow moisture to enter the terminal enclosure.

Measure insulation resistance of the heating elements. This can be carried out by taking a reading between the element sheath and the phase terminals, using a 500v DC megohmmeter. A reading better than 1 megohm should be obtained.

Low megohm may result in high leakage current to ground and nuisance trips of ground fault protection equipment. Normally, the megohm value increases after heat-up. If persistent conditions persist, the heating elements may need to be dried out to remove moisture. Refer to Appendix E for details.

Ensure terminal housing gasket is in good condition and refit cover.

Functional check of all related process controllers, power systems, and safety interlocks.

### **Every 12 months**

Check for element operation by comparing phase resistance values from the legs of each circuit.

On a healthy system these values should be equal (+/- 10%).

When resistance values show a large variance, bussing can be removed from the identified circuit to isolate the underperforming element(s). An open circuit element can be 'un-bussed' from the circuit so that operation can continue. While the legs of the circuit may be unbalanced, this will not affect heater operation outside of the reduced power output. If desired, the unit can be sent back for element replacement at an appropriate time.

Remove heater from its mating flange and check the external condition of the heating elements. Heater elements can be visually inspected for:

Discoloration - due to overheating must be investigated further to ascertain the cause.

Coatings - the presence of fluid fouling, scale build-up, deposits, or similar coatings. Any product build-up on the surface of the element must be cleaned. The use of high pressure steam, water jets, or suitable solvent is acceptable. The chloride content of steam or water shall not exceed 20 ppm, otherwise the element sheath can fail through stress corrosion cracking.

Area around elements should be checked for sediment or sludge build-up that would shorten heater life. Correct operating conditions, as needed, to minimize any sheath deterioration due to corrosion.

Corrosion - the presence of acidic solutions can deteriorate the element sheath. Common indicators include

scaling, pitting, pin-hole, oxidation, or similar degradation of the metal. While corrosion may not always be avoidable, it is best controlled through proper material selection and process flow chemistry. Consult with Chromalox for alternative material selections. In more extreme solutions, full heater replacement may be needed as part of a regular maintenance schedule.

Chromalox will not warrant any electric heater against failure by sheath corrosion if such failure is the result of operating conditions beyond the control of the heater manufacturer. It is the responsibility of the purchaser to make the ultimate choice of sheath materials based on their knowledge of the chemical composition of the corrosive solution, character of materials entering the solution, and controls by which the process can be maintained.

Measure insulation resistance of the heating elements. This can be carried out by taking a reading between the element sheath and the phase terminals, using a 500v DC megohmmeter. A reading better than 1 megohm should be obtained.

Low megohm may result in high leakage current to ground and nuisance trips of ground fault protection equipment. Normally, the megohm value increases after heat-up. If persistent conditions persist, the heating elements may need to be dried out to remove moisture. Refer to Appendix E for details.

Mating surfaces and bolting must be evaluated for potential corrosion and if necessary covered with a rust-preventative suited for the materials and as recommended by the manufacturer.

A new gasket should be used when re-installing heater. Retighten bolt connections per guidelines in Appendix D.

Each heating application is unique. Users are encouraged to reduce the time between maintenance intervals for more severe applications.

It is a warranty requirement to comply with these instructions and documented evidence shall be maintained in the form of a signed checklist as per the Appendix A or operator's equivalent.

**Note:** A completed Maintenance Checklist or equivalent will be required in the event of any safety or warranty claim.

# Fault Finding and Correction

Below is a listing of common occurrences and solutions that may occur during heater operation. This is not an all-inclusive list. Each application is unique, and heating equipment is mostly likely integrated with sensors and controllers outside the scope of this manual. Be sure to consult a certified professional if you are unsure of the situation.

Chromalox Service Department is available at 1-800-443-2640

Fault	Possible Correction
Process temperature is too low	<ul style="list-style-type: none"> <li>• Isolate power supply</li> <li>• Check supply fuses</li> <li>• Check that the temperature control device set points are correct.</li> <li>• Check sensors for correct location, wiring, operation, and accuracy.</li> <li>• Check that all elements are still operative by taking a load resistance reading. Resistance between phases should be equal.</li> <li>• Check that the process flow is matching the design rating.</li> </ul>
Process temperature too high	<ul style="list-style-type: none"> <li>• Check that the temperature control device set points are correct.</li> <li>• Check the actual flow conditions match the design parameters.</li> <li>• Check the sensor location operation</li> </ul>
Heater Shutdown	<ul style="list-style-type: none"> <li>• Check that the supply voltage is correct</li> <li>• Check all trip devices are functioning correctly and sensors have not failed.</li> <li>• Check ambient temperature is within rating</li> <li>• Check overtemperature control settings and adjust as needed</li> <li>• Check any liquid level control settings</li> <li>• Check ground fault settings</li> </ul>
System leakage	<ul style="list-style-type: none"> <li>• Check piping and flange connections are tightened to specifications</li> <li>• Check gasket materials and mating surfaces</li> </ul>
Noisy flow or cavitation	<ul style="list-style-type: none"> <li>• Bleed system to remove any air or steam pockets</li> <li>• Check the actual flow conditions match the design parameters.</li> </ul>

# Health & Safety Statements



## Decommissioning, Disposal, and Recycling

There may come a time when equipment needs to be replaced or is no longer required. Prior to decommissioning, make sure equipment is properly shut down and de-energized. Follow guidelines within installation and maintenance sections of this document to disconnect equipment. Check local codes and regulations for proper disposal and recycling of materials. Chromalox is not responsible for improper disposal.



## ROHS Compliance

This unit complies with the Restriction of Hazardous Substance (ROHS), also known as Directive 20011/65/EU.



## Non-Potable Use Only

Under the US Federal Safe Drinking Water Act, it is unlawful to install or use this product in any service that comes into contact with water for human consumption. This product is intended exclusively for use in non-potable service.

There are no hazardous or toxic substances applied with this equipment.

---

# Service & Replacement Parts

Any service work must be performed by trained personnel.

For on-site technical support, please contact the Chromalox Service Department at 1-800-443-2640. Provide your unit part number, model number, and Chromalox purchase order number to properly identify the equipment.

Replacement parts are available by contacting Chromalox Service Department at 1-800-443-2640. Provide the unit part number, model, voltage, and wattage to properly identify unit.

---

# Warranty

Limited Warranty:

Please refer to the Chromalox limited warranty applicable to this product at <http://www.chromalox.com/customer-service/policies/termsosfale.aspx>.

# Appendix

**Section A** .....Installation, Commissioning, and Maintenance Checklist

**Section B** .....Long Term Heater Storage

**Section C** .....Lifting

**Section D** .....Flange Bolt Tightening Procedure

**Section E** .....Insulation Testing & Dry-out Procedure

# Appendix A

## Maintenance Schedule & Checklist

Equipment Received Date \_\_\_\_\_

Equipment Model Description: \_\_\_\_\_ Chromalox PO # \_\_\_\_\_

Equipment Part Number \_\_\_\_\_ Tag No: \_\_\_\_\_

### Receiving, Storage, Commissioning, & Operation Verification – Performed per Instructions

<b>Equipment received &amp; inspected (within 48 hours)</b>	Date		<b>Equipment stored per Short Term Instructions</b>	Date	
	Sign			Sign	
	Print			Print	
<b>Commissioning performed per Instructions</b>	Date		<b>Start-up Operation performed per Instructions</b>	Date	
	Sign			Sign	
	Print			Print	

This blank form may be photocopied, as required, to record the full service history of the equipment.

### Yearly Maintenance Inspection Verification – Performed per Instructions

<b>3 Month Inspections</b>	Date		Date	
	Sign		Sign	
	Print		Print	
<b>3 Month Inspections</b>	Date		Date	
	Sign		Sign	
	Print		Print	
<b>6 Month Inspections</b>	Date		Date	
	Sign		Sign	
	Print		Print	
<b>12 Month Inspection</b>	Date			
	Sign			
	Print			

This blank form may be photocopied, as required, to record the full service history of the equipment.

#### Notes:

1. This checklist, duly completed, must be submitted with any safety or warranty claims.
2. A separate checklist must be completed for each piece of equipment.
3. Where equipment is removed from service a new checklist must be completed upon re-commissioning.
4. Where equipment has been placed in Long Term Storage, a separate checklist must be maintained to confirmed proper maintenance. Refer to Section B.
5. Where equipment has been supplied certified for use in a hazardous area, compliance with the relevant code of practice and installation instructions, regarding operation and maintenance, shall also be required.

Chromalox has a team of fully trained technicians and engineers who are able to offer a specialist inspection, commissioning, start-up and/or maintenance service. For further details, please contact our service department at 1-800-443-2640

# Appendix B

## Long Term Heater Storage

 The systems shall not be stored outdoors for more than 24 hours. If the system remains outdoors, the entire system must be protected from the outdoor elements with appropriate coverings. It shall be suitably covered for protection against adverse weather, using a tear-free waterproof membrane such as a tarpaulin. The equipment shall be placed on dry ground or on blocks to lift it clear of any possible water.

Shipping containers are temporary protective covers. Additional protection must be taken to prepare unit for storage to ensure sustainability.

When equipment is stored, as listed below, equipment will remain safe and protected for **up to twelve months** in the as-supplied condition. High humidity, tropical, or other extreme environments may require reduced time intervals for each inspection.

During long term storage, any desiccant used must be checked at least once a month, and replaced if needed.

 Unit shall be stored in a heated building with adequate air circulation and protected from dirt and water. Unit shall be stored in a clean, dry space where a uniform temperature prevents condensation. Unit shall be stored a minimum of 6" off the ground. If the stored area is not heated, desiccant shall be removed from the terminal housing and an anti-condensation heater shall be installed and connected to a suitable supply and kept in operation.

An anti-condensation heater must be energized in the heater terminal enclosure. Ensure all conduit holes are properly sealed and covers fully intact and secured.

If no anti-condensation heater or associated power source is available, desiccant shall be used in the heater junction box to prevent moisture intrusion into the heating elements. Desiccant shall have color saturation indicators to ascertain effectiveness. The heater junction box shall be opened monthly and desiccant shall be inspected. Replace when warning indicators indicate a change is required.

Desiccant preservation warning labels to be attached at each access point.

VCI (Volatile Corrosion Inhibitors) shall be used in all terminal enclosures during long term storage and regularly checked for effectiveness. VCI can be changed per manufacturer's recommendations.

For units that have unprotected metal surfaces on the internal chamber and/or heating elements, a nitrogen blanket may be installed to help limit oxidation or corrosion that could occur during storage.

All openings shall be properly covered by caps, plugs, water-proof tape, etc.

All fragile parts, sharp edges, and projection shall be properly cushioned.

If flanges are opened for inspection during storage, mating faces shall be cleaned and the gaskets renewed before covers are replaced. Nozzles and flanges shall be blanked with a full face gasket and plate blank flange (coated with primer) secured by 4 bolts minimum, (coated with preservative).

Any spare heater elements shall be stored in the same manner as the primary unit.

### Recommended Sizing for Desiccant bags with Color Saturation Indicators

Drying agents should be inspected regularly and replaced when necessary. The desiccant is to be fitted prior to dispatch. Quantity to be calculated from the following equation:

$$\frac{A \times R \times M \times D}{74} = \frac{W}{2}$$

#### Where:

W = Weight, in kg, of the basic desiccant

A = Area, in square meters, of water vapor-proof barrier

D = Weight, in kg, of hygroscopic blocking, (timber cushioning), and other materials inside barrier

M = Maximum time of storage, in months, (12 min)

R = Water vapor transmission rate of the barrier, in grams per square meter per 24 hours, measured at 90% relative humidity differential and 38°C

The waterproof barrier will be polythene, and the transmission rate is dependent on thickness. Standard thickness is 0.25mm, for which R = 2.

# Long Term Heater Storage

## Long Term Storage Checklist

Equipment Received Date: \_\_\_\_\_ Placed in Storage Date: \_\_\_\_\_

Equipment Model Description: \_\_\_\_\_ Chromalox PO # \_\_\_\_\_

Equipment Part Number: \_\_\_\_\_ Tag No: \_\_\_\_\_

Proper long term storage includes regularly scheduled maintenance checks-to ensure the integrity of both the unit and storage location.

### **Every three months:**

Sealed, shrink-wrapped, or plastic covered areas shall be visually inspected to confirm integrity of the wrapping material. No moisture or condensation should be present.

Confirm anti-condensation heaters are still operating correctly.

Any desiccant or drying materials must be inspected and replaced if necessary.

Inspect all covers, caps, taping, or similar devices for seal integrity. Retighten or replace if loosened.

Confirm surrounding condition for proper compliance – ambient temperature maintained, no roof leakage, no moisture on floor, no work being performed in area, etc.

### **Storage Verification Checklist – Performed per Instructions**

<b>3 Month Inspections</b>	Date		Date	
	Sign		Sign	
	Print		Print	
<b>3 Month Inspections</b>	Date		Date	
	Sign		Sign	
	Print		Print	

This blank form may be photocopied, as required, to record the full service history of the equipment.

**Every twelve months:**

The unit must be unpacked from storage so that a complete visual inspection can be done of all internal components – bussing, wiring, sensor housings, heating elements, etc. Care should be given to note any signs of corrosion, moisture, physical damage or similar damage that may have resulted from improper storage or damage to the packaging that may have occurred during storage.

If any damage is noted, please contact Chromalox Service Department at 1-800-443-2640 for recommendations of proper repair.

Upon satisfactory inspection of the equipment and storage are, the unit may once again be repackaged per the Long Term Storage Instruction, if needed.

**Storage Verification Checklist – Performed per Instructions**

<b>12 Month Inspections</b>	Date		Date	
	Sign		Sign	
	Print		Print	
<b>12 Month Inspections</b>	Date		Date	
	Sign		Sign	
	Print		Print	

This blank form may be photocopied, as required, to record the full service history of the equipment.

If unit is to be removed from Long Term Storage for operation, a complete mechanical and electrical inspection must be performed. Refer to the Installation Manual for complete details.

Chromalox has a team of fully trained technicians and engineers who are able to offer a specialist inspection, commissioning, start-up and/or maintenance service. For further details, please contact our service department at 1-800-443-2640

# Appendix C

## Proper Lifting for Heater Bundles

An immersion heater requires extra care as to not damage the individual heating elements in the bundle during any lifting procedure.

Note that any lifting eyes provided on a heater bundle are specifically designed for only heater removal from a vessel or tank. The customer must install suitable rated lifting eyes or lugs for their intended lifting method.

Ensure that lifting equipment is of the correct capacity. Due to the uneven weight distribution, care must be taken to ensure that the bundle is lifted in such a way that it does not slant or become inclined during transport.

The immersion heater can be installed either by use of a crane or by a 'running' block and tackle attached to an overhead stiffener beam (reference figure C.1 as an example). Longer bundles should be lifted by two cranes (or two sets of blocks and tackles).

Multiple slings should be placed under multiple spacer/baffle (span not to exceed 84") to evenly distribute the weight of the bundle. Do not position slings or supports directly under the elements and damage will occur. While some element distortion is acceptable, excess bending can eliminate the proper spacing between elements. This can result in reduced flow characteristics, overheating, and ultimate failure of the elements.

1. Hook the chains of lifting device to lifting eyes on bundle flange, and tension. Locate lifting eyes with the aid of the drawings provided.

If applicable, hook the chains of the second lifting device to a baffle along the length of the bundle.

2. Fit gasket over the elements and orient correctly on the flange face. Ensure the bundle is oriented correctly per the design specification.
3. Carefully begin inserting bundle, ensuring both lifting devices are moving in synchronization and taking extreme care to avoid pinch points.

As the bundle progresses into the vessel, remove each successive sling at the entry point into the vessel.

4. Continue slowly inserting bundle.

When bundle is fully inserted, bolt bundle flange to vessel flange and torque bolting per specifications. Refer to Appendix D.

5. Remove chains from flange bundle.

The unit is now ready for electrical connection.

This procedure should be followed in reverse for removal of bundle.

**Figure C.1:**  
Example removal procedure (for reference only)

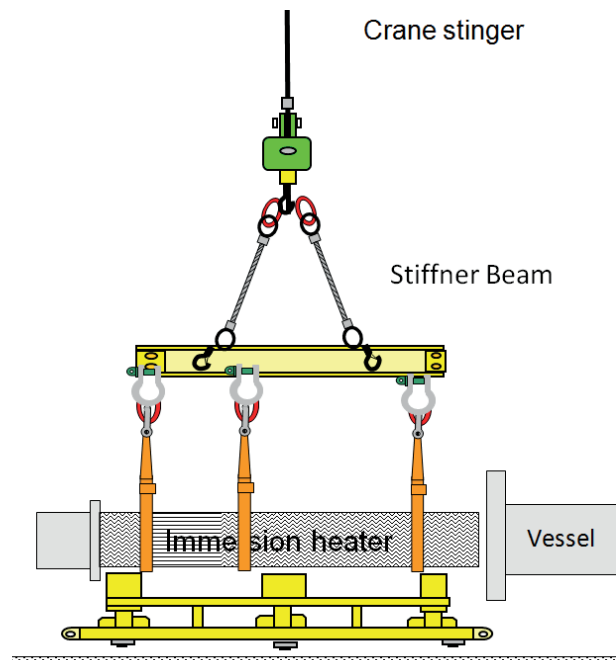

# Appendix D

## Flange Tightening Guidelines

The bolt tightening procedure is as follows:

Flange faces must be thoroughly cleaned and inspected. Surface marks extending across the joint face or heavy pitting are not acceptable.

The alignment of the flanges must be in accordance with the tolerance quoted in the vessel code and manufacturing standard.

1. The gasket or sealing ring must be inspected immediately prior to use.
2. Insert stud bolts and fit the nuts so they are finger tight, checking that there is an equal protrusion of stud bolt through each nut.
3. Stud bolt tightening shall be carried out in stages to predetermined sequence. Acceptable tightening sequences are shown in Figures D.1 and D.2. The sequences shown in Figure 5.2 should be used until any flange misalignment is taken up.
4. Throughout the stud bolt tightening sequence, frequent checks shall be made to ensure parallel 'pull-up' of the flanges.
5. Final tightening should be carried out by torque measurement to the value given in Table D.1. To ensure its accuracy, the torque wrench should be calibrated regularly.
6. After final assembly of the flanges, the screw thread protruding beyond the nut faces must be protected against corrosion. The use of flange protectors should also be considered.

**Figure D.1: Typical Bolt Tightening Sequence**

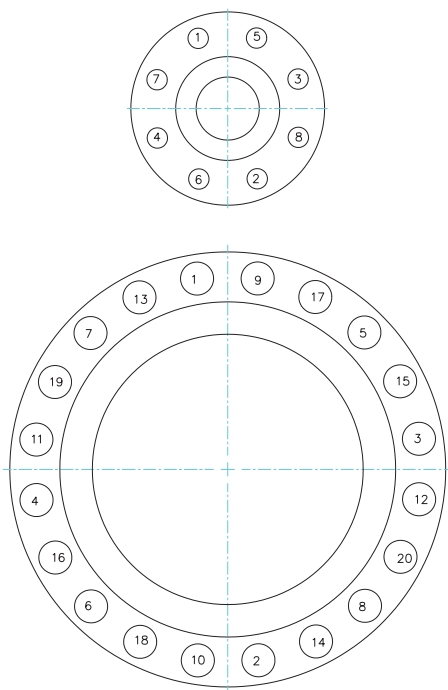

**Figure D.2: Typical Bolt Tightening Sequence to Take Up Angular Misalignment**

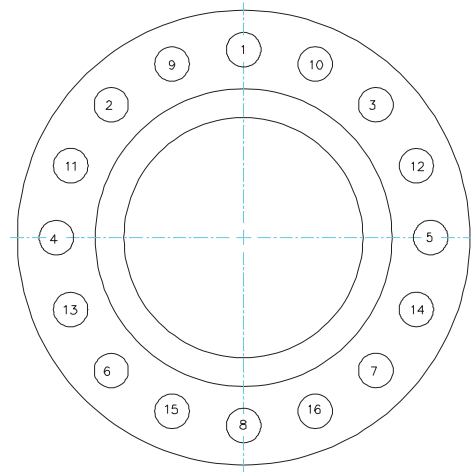

**Table D.1: Bolting Torque**

Bolt Diameter (Inches)	Min. Torque (Nm)	Max. Permitted Torque (Nm)
1/2	65	90
5/8	130	180
3/4	230	315
7/8	370	515
1	560	770
1 1/8	810	1150
1 1/4	1135	1625
1 1/2	2030	2925
1 5/8	2620	3805
1 3/4	3295	4785
1 7/8	4105	5960
2	5010	7325
2-1/2	10050	14840

**Notes:**

1. The recommended minimum torque figures given above are considered to be sufficient for normal purposes and take into account permitted misalignment between flanges.
2. If necessary, a torque greater than the recommended minimum may be used but the maximum permitted torque should not be exceeded.

# Appendix E

## Electric Heaters with Low Insulation Resistance (Megohms)

### **⚠ WARNING**

**HIGH VOLTAGE EQUIPMENT TESTING---RISK OF ELECTRIC SHOCK OR ELECTROCUTION. All procedures described below shall only be performed by qualified personnel. Failure to observe proper safety procedures could cause injury or death. All power must be disconnected prior to attempting any work on equipment. Test equipment described creates high voltages. Proper safety equipment must be worn during tests.**

### **⚠ CAUTION**

**Equipment damage can occur if proper precautions are not taken. The following is general description of testing of electric heating equipment. It is not intended to be a complete guide to trouble shooting. This information is believed to be accurate but does not completely identify all limitations and equipment impacts. No warranty is implied or given by Chromalox related to the use of this information. This information is to be used at the equipment owner's risk. Material can be returned to Chromalox for inspection if there is any concern regarding use of this information. Chromalox Field Service people are also available to assist as required at the equipment location. For any assistance, please contact Chromalox Service Department at 1-800-443-2640.**

### Introduction

One of the more common field problems is an electric heater that is reported to have low insulation resistance (Megohm values) after it has been shipped from the factory, removed from storage, or installed in the application. This is particularly common with large assemblies such as flanged immersion heaters, circulation heaters, or duct heaters. The following discussion and recommendations while directed toward multiple element assemblies are appropriate for all field installed electric heaters including individual elements.

### Characteristics

The refractory material magnesium oxide (MgO) used in electric heating elements is very hygroscopic and may absorb moisture. This moisture can be absorbed from the humidity in the air during transit, storage, long down times or when exposed to a humid environment. The heater terminals do not have to be sprayed or immersed in water for this to occur although the problem

is frequently caused by terminal housings being left open during installation allowing water and/or rain to enter the enclosure. Moisture enters the open ends of the element (terminals) as humidity in the air and permeates throughout the MgO. Typically this process occurs very slowly over time with most of the moisture initially concentrating in the end of the element near the terminal.

### Problems Associated with Moisture Absorption:

As the MgO absorbs moisture, the insulation resistance (Megohm value) decreases proportionately. In most heating elements, the amount of moisture absorbed by the MgO is negligible and is quickly driven off when the heater is energized. However, if moisture absorption process continues for an extended period of time, the MgO in the entire element may eventually become saturated with moisture. The end result is an element or heater with abnormally low insulation resistance. If the insulation resistance is low enough, it may result in a high leakage current to ground that can cause nuisance trips of ground fault protection equipment (GFI) when the heater is energized. In some instances the presence of moisture in the MgO may actually cause a dielectric breakdown (short circuit) and element failure during the initial heater start up.

**Determining a Low Megohm Condition** – Insulation resistance is usually measured using a 500V DC potential between live circuits (heater terminals) and the chassis (ground). At time of shipment from the factory, typical insulation resistance values range from 5 Megohms or greater for unsealed multiple assemblies to 20 Megohms or greater for individual elements. Often the insulation resistance value of an unsealed heater or heating element can drop quickly after shipment from the plant but can recover quickly during the initial heat up. In fact in many high temperature applications, it is preferred to leave the elements unsealed so they can “breathe” during operation. In other situations the moisture must be removed from the element prior to start up to prevent a possible dielectric failure.

### Dry Out Procedures:

While low insulation resistance usually does not affect heater efficiency or life, it can cause serious electrical problems during initial startup. Therefore, as a general rule, it is recommended that any heating element and/or heater assembly with less than 1 Megohm insulation resistance per circuit be dried out before applying full power.

Large flange heaters with multiple elements and/or very long elements on each circuit may have relatively low Megohm values due to the combined parallel insulation resistance of multiple elements. If you are unsure of the proper readings for your equipment, please contact the Chromalox Service Department at 1-800-443-2640.

If a heater or heater assembly has a low or questionable insulation resistance (Megohms) the recommended procedure is to contact the Chromalox Service Department for further instructions at 1-800-443-2640. If it is determined that the heater has an unacceptably low insulation resistance and cannot be easily repaired in the field, the Service Department may issue a material return authorization (MRA) for rework and dry out at the factory.

#### **Alternate Dry Out Procedures:**

If it is not practical to return the heater to the factory for rework, the insulation resistance of many heaters can usually be restored (dried out) in the field by using one or more of the following procedures. These procedures only apply to heaters and heating elements that are unsealed or only have simple moisture barriers on the element terminals (RTV, conformal coating, or silicone resin). Heaters with sealed terminals, such as epoxy or hermetic (glass to metal) seal cannot effectively be dried out in the field. Units will need to be returned to Chromalox for repair.

1. **Drying Out an Installed Heater:** Energize the heater at approximately 1/2 the rated voltage (1/4 Wattage). Operating the heater under these conditions produces enough heat in the elements to drive the moisture out while reducing the risk of overheating the equipment. However, even at 1/4 of the wattage it is possible to overheat and damage the equipment or the heated media. The temperatures of the element sheath material, heated media and associated process equipment must still be limited to safe values. Failure to limit sheath temperatures could permanently damage the elements and void the equipment warranty. If the heater has an over temp control or sensor, use this device to limit the operating temperature (sheath temperature) to safe limits during the dry out process. Continue the process until the heater circuits read 1.0 Megohm or higher.

**Note:** If the heater has a phase angle SCR / Thyristor control, set the SCR / Thyristor controller manually for 1/2 on. This procedure will produce 1/4 of the wattage while limiting the peak voltage applied to the heater to approximately 1/2 of the rated voltage.

**Note:** Heater with standoff construction can not be dried using the low voltage method alone as the heat will not adequately travel through the standoff area. An alternative is to wrap the standoff area with a heated or welding blanket in combination with the lowered voltage. Ensure all equipment in the immediate area is rated for the drying temperatures.

2. **Procedure for Heaters that cannot be Dried Out in Place:** Uninstall the heater. Remove the terminal enclosure, hardware, gaskets, wiring and any other devices that may be damaged by heat. Heaters with non-removable housings shall have the covers and gaskets removed prior to baking. Bake the entire element or heater assembly in an oven set at approximately 300°F to 350°F (150°C to 175°C) for several hours, preferably overnight. Baking ovens that are large enough to accommodate large flange heaters may be found at local electric motor rewind shops.

#### **Maintaining Insulation Resistance**

Normally a heater with an acceptable insulation resistance will continue to maintain its optimum insulation resistance if operated on a frequent or daily basis. Non-operating units may develop low insulation reading due to a variety of factors including high humidity environments, condensation, or rapid ambient temperature fluctuations. Moisture can not only be absorbed in heating elements, but also accumulate on bussing, terminals, and exposed wiring in the terminal housing.

To help prevent moisture ingress, seal opening(s) in the terminal housing and provide a dry nitrogen purge, instrument air purge, or heated air above the current dew point. Install the appropriate anti-condensation heater in the terminal enclosure to be used during non-operating periods.

**Limited Warranty:**

Please refer to the Chromalox limited warranty applicable to this product at  
<http://www.chromalox.com/customer-service/policies/termsofsale.aspx>.

**Chromalox, Inc.**  
**103 Gamma Drive**  
**Pittsburgh, PA 15238**  
**(800) 443-2640**  
**[www.chromalox.com](http://www.chromalox.com)**