

Installation Instructions

Installation of Tubular Element with Fittings

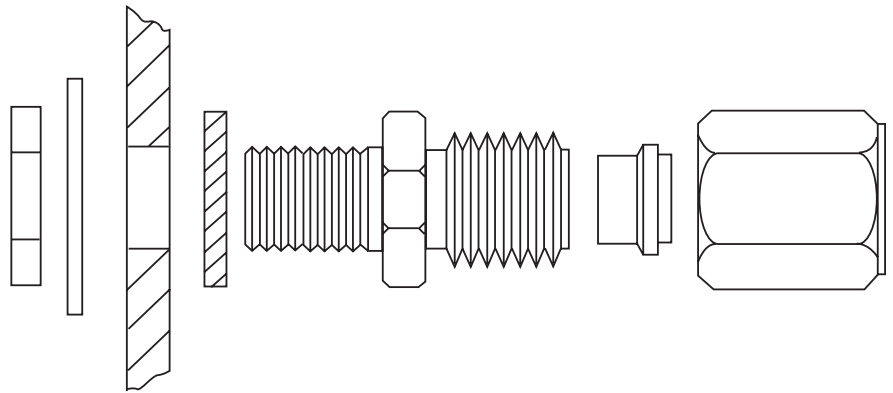

PB403-4
161-053345-001
April 2020

Installation

⚠ WARNING

HAZARD OF ELECTRIC SHOCK. Disconnect all power before equipping tubular heating element with compression fittings.

⚠ WARNING

Care must be taken to insure the heated portion does not extend into the compression fittings.

1. Slide compression nut, ferrule and fitting onto sheath of tubular element.
2. Place gasket on fitting and insert fitting with element thru tank wall.
3. Assemble washer and nut, and tighten to suit.
4. Check position of element and tighten compression nut to produce desired seal.

IMPORTANT: When mounting the heater in a tank containing liquid, mount the heater in the tank so the liquid level will always be above the effective heated portion of the heater. If the heater is not properly submerged, it may overheat and damage the heating elements and create a possible fire hazard due to excessive sheath temperatures.

⚠ WARNING

It is the responsibility of the purchaser of the heater to make the ultimate choice of sheath material based upon his knowledge of the chemical composition of the corrosive solution, character of the materials entering the solution, and controls which he maintains on the process. Chromalox cannot warrant any electric immersion heater against failure by sheath corrosion. Corrosion failure is the result of operating conditions beyond our control.

⚠ WARNING

HAZARD OF ELECTRIC SHOCK. Any installation involving electric heaters must be grounded to earth to eliminate shock hazard.

***NOTE:** Each package contains parts for 2 complete fitting assemblies including compression nuts, ferrules, threaded fittings, gaskets, washers, hex nuts.

⚠ WARNING

DANGER: HAZARD OF FIRE — Since the heaters are capable of developing high temperatures, extreme care should be taken to:

- a. Avoid contact between heater and combustible materials.**
- b. Keep combustible materials far enough away to be free of the effects of high temperatures.**

Maintenance

Read this First

Disconnect power before performing any maintenance or repair. Allow element to cool below 140°F (60°C) before performing maintenance or repair. Maintenance and repair should be performed only by qualified personnel.

Preventative Maintenance

Dust and moisture contamination are typically the largest contributors to a heating elements premature failure.

To avoid failure from overheating, it is recommend that a regular maintenance routine include cleaning the element and element cover with compressed air. Routinely check wiring for signs of overheating or damage. Ensure that all electrical spacings are intact.

Storage

It is also important to ensure that while in storage, the heating element is kept in a dry area. If this cannot be accomplished, it is recommended that the elements be sealed in a moisture resistant bag or wrapped with plastic. A desiccant should also be placed near the element terminals during storage.

Dryout Procedure or Low Megohm Readings

Moisture contamination can be removed from heating elements in the field using several methods. For un-installed heaters, simply place the heater in an 200°F (94°C) oven for 1 hour.

Drying Out an Installed Heater

Energize the heater at approximately 1/2 the rated voltage (1/4 Wattage). Operating the heater under these conditions produces enough heat in the elements to drive the moisture out while reducing the risk of overheating the equipment. However, even at 1/4 wattage it is possible to overheat and damage the equipment or the heated media. The temperatures of the element sheath material, heated media and associated process equipment must still be limited to safe values. Failure to limit sheath temperatures could permanently damage the elements and void the equipment warrantee. If the heater has an over temp control or sensor, use this device to limit the operating temperature (sheath temperature) to safe limits during the dry out process. Continue the process until the heater circuits read 1.0 Megohm or higher.

Note: If the heater has a phase angle SCR control, set the SCR controller manually for 1/2 on. This procedure will produce 1/4 wattage while limiting the peak voltage applied to the heater to approximately 1/2 rated voltage.

Troubleshooting

If after properly following startup procedure, recheck all wire connections. If heaters still do not operate it is most likely due to failure of the internal heating coil and the element must be replaced.

Limited Warranty:

Please refer to the Chromalox limited warranty applicable to this product at <http://www.chromalox.com/customer-service/policies/termsofsale.aspx>.

Chromalox[®]
PRECISION HEAT AND CONTROL

1347 HEIL QUAKER BLVD., LAVERGNE, TN 37086
Phone: (615) 793-3900 www.chromalox.com