

# INSTALLATION & OPERATION INSTRUCTIONS

## 6140/4140 Temperature & Process Controllers





# CONTENTS

<b>CONTENTS</b> .....	<b>3</b>	3.3. First power-on.....	35
<b>Introduction</b> .....	<b>7</b>	3.3.1. Fast configuration.....	35
Device data.....	7	3.4. Setting up quick configuration.....	40
Warnings and safety.....	7	3.4.1. Setting up the Alarm.....	40
Typographical conventions used in this manual.....	8	3.4.2. Setting up the Heater Break Alarm.....	41
Glossary.....	8	3.4.3. Setting up the PID.....	42
Disclaimer.....	9	<b>4. Configuration</b> .....	<b>45</b>
Copyright.....	9	4.1. Programming/Configuration Menu.....	45
<b>1. General description</b> .....	<b>11</b>	4.1.1. First: know what you're doing.....	45
1.1. Profile.....	11	4.1.2. Passwords.....	45
1.2. Differences among models.....	12	4.1.3. Password in the User Menu.....	45
1.3. 6140 Controller.....	13	4.2. Main menu.....	46
1.3.1. Display and keys.....	13	4.3. Legend for submenus and parameters.....	47
1.3.2. Drilling dimensions and templates.....	14	4.3.1. Submenu.....	47
1.5. 4140 Controller.....	17	4.3.2. Parameters.....	47
1.5.1. Display and keys.....	17	4.4. INFO Submenu - information display.....	48
1.5.2. Drilling dimensions and templates.....	18	4.4.1. SW.VER - Versione software.....	49
<b>2. Installation</b> .....	<b>19</b>	4.4.2. CODE - Identifying code of controller.....	49
2.1. Mounting the controller.....	19	4.4.3. ERROR - Main input error.....	49
2.1.1. General installation rules.....	19	4.4.4. SAP.C - SAP code.....	49
2.1.2. Drilling dimensions.....	19	4.4.5. SER.n - Serial number of controller.....	49
2.1.3. Protection against infiltration of dust.....	19	4.4.6. xxxxx - Model of controller.....	50
and.....	19	4.4.7. xxxxx - Type of controller.....	50
water.....	19	4.4.8. L.FUNC - Option Logic Functions available.....	50
2.1.4. Vibrations.....	20	4.4.9. IN.SPR - Remote setpoint input available.....	50
2.1.5. Minimum space for ventilation.....	20	4.4.10. OUT.A1 - Analog output 1 available.....	50
2.1.6. Positioning.....	20	4.4.11. CTx - Current transformer input available.....	51
2.1.7. Fastening to the panel.....	20	4.4.12. x.IN.DG - Digital input available.....	51
2.2. Connections.....	21	4.4.13. RS485 - RS485 serial port available.....	51
2.2.1. General rules for connections.....	21	4.4.14. Out1 - Type of output 1.....	51
2.2.2. Electromagnetic compatibility (EMC).....	21	4.4.15. Out2 - Type of output 2.....	51
2.2.3. Cables.....	21	4.4.16. Out3 - Type of output 3.....	52
2.2.4. Power supply.....	21	4.4.17. Out4 - Type of output 4.....	52
2.2.5. Connecting inputs and outputs.....	22	4.4.18. OUT1.S - Number of switchings output 1.....	52
2.3. 6140 connection diagrams.....	23	4.4.19. OUT2.S - Number of switchings output 2.....	52
2.3.1. General diagram.....	23	4.4.20. OUT3.S - Number of switchings output 3.....	52
2.3.2. Power supply.....	24	4.4.21. OUT4.S - Number of switchings output 3.....	53
2.3.3. Inputs.....	24	4.4.22. T.DAYS - Total working days.....	53
2.3.4. Outputs.....	24	4.4.23. P.DAYS - Partial working days.....	53
2.3.5. Options.....	25	4.4.24. T.INT - Internal temperature of controller.....	53
2.4. 4140 connection diagrams.....	27	4.4.25. T.MIN - Minimum internal temperature of the controller.....	53
2.4.1. General diagram.....	27	4.4.26. T.MAX - Maximum internal temperature of the controller.....	54
2.4.2. Power supply.....	28	4.4.27. tiME - Internal time.....	54
2.4.3. Inputs.....	28	4.4.28. dAtE - Internal date.....	54
2.4.4. Outputs.....	28	4.5. PR.OPT Submenu - Configuring programs.....	55
2.4.5. Digital inputs.....	29	4.5.1. PR.OPT - Selecting program.....	56
2.4.6. Serial line.....	29	4.5.2. FI.STP - Number of first step assigned to program.....	56
2.4.7. CT Inputs.....	29	4.5.3. LA.STP - Number of last step assigned to program.....	56
2.4.8. Remote setpoint input.....	30	4.5.4. Strt - Restart mode.....	56
2.4.9. Analog output.....	30	4.5.5. RST.SP - Type of control after program restart.....	57
2.5. RS485 serial connection diagram.....	31	4.5.6. WAIT.S - Option to start execution of program.....	57
<b>3. Commissioning</b> .....	<b>33</b>	4.5.7. End - Action at end of program.....	57
3.1. Information on displays and use of keys.....	33	4.5.8. LIMIT - Limitation of step duration.....	57
3.1.1. Navigating the menus.....	33	4.6. PR.STP Submenu - Configuration of program steps.....	58
3.1.2. Displays.....	33	4.6.1. PR.NUM.....	60
3.1.2.1. Display characters.....	33	4.6.2. PR.ST.N - Programming step.....	60
3.2. Sequence at power-on.....	34	4.6.3. ST.END - Setting the final step in the program.....	60
3.2.2. Scrolling messages.....	34	4.6.4. SETP - Programming step setpoint.....	60
		4.6.5. RAMP.T - Step time ramp.....	61
		4.6.6. HOLD.T - Hold time in step.....	61
		4.6.7. HBB - Enable Hold Back Band function.....	61
		4.6.8. BAND - Maximum deviation for HBB.....	61
		4.6.9. HBB.R - Enabling HBB during ramp.....	62
		4.6.10. HBB.H - Enabling HBB during hold.....	62
		4.6.11. HBB2 - Enabling HBB with respect to I.SPR.....	62

# CONTENTS

4.6.12.	S.SP.EN - Enabling retransmission of setpoint .....	62			
4.6.13.	SUB.SP - Setpoint value of slaved controller .....	63			
4.6.14.	S.RM.EN - Enabling ramp for slaved controller .....	63			
4.6.15.	ENBL.1 - Consent 1 to execute step .....	63			
4.6.16.	ENBL.2 - Consent 2 to execute step .....	63			
4.6.17.	ENBL.3 - Consent 3 to execute step .....	64			
4.6.18.	ENBL.4 - Consent 4 to execute step .....	64			
4.6.19.	EVN.R.1 - Event 1 during step ramp .....	64			
4.6.20.	EVN.R.2 - Event 2 during step ramp .....	64			
4.6.21.	EVN.R.3 - Event 3 during step ramp .....	65			
4.6.22.	EVN.R.4 - Event 3 during step ramp .....	65			
4.6.23.	EVN.H.1 - Event 1 during step hold .....	65			
4.6.24.	EVN.H.2 - Event 2 during step hold .....	65			
4.6.25.	EVN.H.3 - Event 3 during step hold .....	66			
4.6.26.	EVN.H.4 - Event 4 during step hold .....	66			
4.6.27.	GROP.R - Group of parameters assigned to ramp .....	66			
4.6.28.	GROP.H - Group of parameters assigned to hold .....	66			
4.6.29.	MSG.R - Message associated with the ramp .....	67			
4.6.30.	MSG.H - Message associated with the maintenance .....	67			
4.7.	I.MAIN Submenu - Configuration of main input .....	68			
4.7.1.	tyPE - Selecting sensor type .....	69			
4.7.2.	SBR.E - Enabling SBR error .....	70			
4.7.3.	Lin - Selecting linearization type .....	71			
4.7.4.	Unit - Selecting the displayed unit of measurement .....	71			
4.7.5.	FILT - Digital filter .....	71			
4.7.6.	FILT.D - Digital filter on PV display .....	72			
4.7.7.	DEC.P - Number of decimals displayed .....	72			
4.7.8.	LO.SCL - Lower limit of scale .....	73			
4.7.9.	HI.SCL - Upper limit of scale .....	73			
4.7.10.	OF.SCL - Scale offset correction .....	74			
4.7.11.	LO.SP - Lower limit for setpoint .....	74			
4.7.12.	HI.SP - Upper limit for setpoint .....	74			
4.7.13.	LO.AL - Lower limit for alarms .....	74			
4.7.14.	HI.AL - Upper limit for alarms .....	74			
4.8.	I.SPR Submenu - Configuration of remote setpoint input .....	75			
4.8.1.	t.SP.r - Selecting type of remote setpoint input .....	76			
4.8.2.	F.SP.r - Selecting remote setpoint input function .....	76			
4.8.3.	Lin.S - Selecting linearization type .....	76			
4.8.4.	FILT.S - Filtro digitale .....	76			
4.8.5.	LO.SPR - Minimum scale limit .....	77			
4.8.6.	HI.SPR - Maximum scale limit .....	77			
4.8.7.	OF.SPR - Scale offset correction .....	77			
4.9.	I.CT1 Submenu - Configuration of current transformer CT1 .....	78			
4.9.1.	FILT.1 - Digital filter .....	79			
4.9.2.	HI.CT1 - Maximum scale limit .....	79			
4.9.3.	OF.CT1 - Scale offset correction .....	79			
4.10.	I.CT2 Submenu - Configuration of current transformer CT2 .....	80			
4.10.1.	FILT.2 - Digital filter .....	81			
4.10.2.	HI.CT2 - Maximum scale limit .....	81			
4.10.3.	OF.CT2 - Scale offset correction .....	81			
4.11.	ALARM Submenu - Configuration of alarms .....	82			
4.11.1.	ALARM - Selecting the alarm to be configured .....	83			
4.11.2.	rEF.x - Selecting the alarm reference .....	83			
4.11.3.	d.i.x - Selecting direct or inverse alarm .....	83			
4.11.4.	A.r.x - Selecting absolute or deviation alarm .....	83			
4.11.5.	n.S.x - Method for applying hysteresis .....	84			
4.11.6.	PWON.E - Disabling the alarm at power-on .....	84			
4.11.7.	LATCH - Memorizing the alarm .....	84			
4.11.8.	HYSTE - Hysteresis .....	85			
4.11.9.	DELAY - Alarm trip delay .....	85			
4.11.10.	MSG.AL - Message associated with tripping of alarm .....	85			
4.11.11.	BLK.AL - Flashing of PV display .....	85			
4.12.	AL.HB Submenu - Configuring the Heater Break alarm .....	86			
4.12.1.	LOW.ON - Alarm due to insufficient current draw .....	87			
4.12.2.	HIG.ON - Alarm due to excessive current draw .....	87			
4.12.3.	HI.OFF - Alarm due to excessive current draw .....	87			
4.12.4.	TIME - HB alarm trip delay .....	87			
4.12.5.	THR.PE - Percentage of HB current compared to calibration .....	88			
4.12.6.	OUT - Control output associated with HB alarm .....	88			
4.12.7.	LoAd - Selecting type of connected load .....	88			
4.12.8.	MSG.HB - Message associated with tripping of HB alarm .....	88			
4.12.9.	BLK.HB - Flashing of PV display .....	89			
4.13.	PID Submenu - Configuring control parameters .....	90			
4.13.1.	S.TUNE - Enabling Self-Tuning .....	91			
4.13.2.	SOFT.S - Enabling Soft-Start .....	91			
4.13.3.	SOFT.T - Soft-Start Time .....	91			
4.13.4.	A.TUNE - Enabling Auto-Tuning .....	91			
4.13.5.	Aut.t - Selecting type of Auto-Tuning .....	92			
4.13.6.	Cntr - Selecting type of control .....	92			
4.13.7.	DERV.S - Derivative sampling time .....	92			
4.13.8.	H.PB - Proportional heating band or hysteresis in ON-OFF control .....	93			
4.13.9.	H.IT - Integral heating time .....	93			
4.13.10.	H.DT - Derivative heating time .....	93			
4.13.11.	H.PHI - Maximum limit of heating power .....	93			
4.13.12.	H.PLO - Minimum limit of heating power .....	93			
4.13.13.	COOL - Selecting cooling fluid .....	94			
4.13.14.	C.SP - Cooling setpoint with respect to heating setpoint .....	94			
4.13.15.	C.PB - Proportional cooling band or hysteresis in ON-OFF control .....	94			
4.13.16.	C.IT - Integral cooling time .....	94			
4.13.17.	C.DT - Derivative cooling time .....	94			
4.13.18.	C.PHI - Maximum limit of cooling power .....	95			
4.13.19.	C.PLO - Minimum limit of cooling power .....	95			
4.13.20.	RESET - Manual reset .....	95			
4.13.21.	P.RST - Potenza di reset .....	95			
4.13.22.	A.RST - Antireset .....	95			
4.13.23.	FEEDF - Feedforward power .....	96			
4.13.24.	DEAD.B - Deadband .....	96			
4.13.25.	FAULT - Fault action power .....	96			
4.13.26.	GRAD.I - Setpoint gradient in increase .....	96			
4.13.27.	GRAD.D - Setpoint gradient in decrease .....	96			
4.13.28.	Unit - Unit of measurement of gradient .....	97			
4.13.29.	GRAD.O - Gradient of control output .....	97			
4.13.30.	LBA.TM - Tripping delay .....	97			
4.13.31.	LBA.PW - Power delivered when LBA alarm trips .....	97			
4.14.	PID.GR Submenu - Configuring groups of control parameters .....	98			
4.14.1.	PID.G.R - Selecting the parameter group to be configured .....	99			
4.14.2.	H.PB - Proportional heating band or hysteresis in ON-OFF control .....	99			
4.14.3.	H.IT - Integral heating time .....	99			
4.14.4.	H.DT - Derivative heating time .....	99			
4.14.5.	H.PHI - Maximum heating power .....	99			
4.14.6.	H.PLO - Minimum limit of heating power .....	100			
4.14.7.	C.PB - Proportional cooling band or hysteresis in ON-OFF control .....	100			
4.14.8.	C.IT - Integral cooling time .....	100			
4.14.9.	C.DT - Derivative cooling time .....	100			
4.14.10.	C.PHI - Maximum limit of cooling power .....	100			
4.14.11.	C.PLO - Minimum limit of cooling power .....	101			
4.14.12.	PV.THR - Threshold PV for the activation of the group of PID parameters .....	101			
4.15.	I.DIGT Submenu - Configuring digital inputs .....	102			
4.15.1.	I.DIG.N - Selecting the digital input .....	103			
4.15.2.	S.in.x - Defining the input state .....	103			
4.15.3.	F.in.x - Selecting the assigned function .....	104			
4.15.4.	ST.EN.N - Setting assigned consent number .....	104			
4.15.5.	MSG.IN - Selecting the digital input message .....	105			
4.16.	OUTPU Submenu - Configuring outputs .....	106			
4.16.1.	OUT.N - Selecting the output .....	106			
4.16.2.	S.ou.x - Defining the output state .....	107			
4.16.3.	F.ou.x - Selecting the function assigned to relay, logic or Triac output .....	107			
4.16.4.	F.ou.C - Selecting the function assigned to continuous output .....	108			
4.16.5.	EVNT.N - Setting the event number .....	108			
4.16.6.	FB.OU.N - Setting the Function Block output number .....	108			
4.16.7.	IN.DG.N - Setting the digital input number .....	108			
4.16.8.	SWTCH - Setting the number of switchings for signal .....	109			

4.16.9.	FAULT - State of output with broken input .....	109	4.23.	HMI Submenu – Configuring the display and keypad .....	131
4.16.10.	MSG.OU - Selecting the output message .....	109	4.23.1.	but.1 - Selecting function key 1 .....	132
4.16.11.	CY.TIM - Cycle time of output.....	110	4.23.2.	but.2 - Selecting function key 2 .....	132
4.16.12.	POWER - Power of output.....	110	4.23.3.	but.3 - Selecting function key 3 .....	132
4.16.13.	P.PERC - Percentage of HEAT or COOL output power .	110	4.23.4.	dS.SP - Selecting the SV display .....	133
4.17.	OUT.AN - Submenu – Configuring the analog retransmission		4.23.5.	dS.F - Selecting the F display.....	133
	output.....	111	4.23.6.	bArG - Selecting the bargraph display .....	133
4.17.1.	S.o.A1 - Defining the state of the analog output .....	112	4.23.7.	LED.1 – Enable RUN led flashing.....	134
4.17.2.	t.o.A1 - Defining the type of analog output.....	112	4.23.8.	MSG.LO - Selecting the message assigned to Low	134
4.17.3.	F.o.A1 - Selecting the function assigned to the analog		4.23.9.	MSG.HI - Selecting the message assigned to HIGH.....	134
	output.....	112	4.23.10.	MSG.ER - Selecting the message assigned to Err .	134
4.17.4.	LO.A1 - Scale minimum .....	112	4.23.11.	MSG.SB - Selecting the message assigned to Sbr.	135
4.17.5.	HIA1 - Scale maximum .....	113	4.23.12.	LANg - Selecting language for messages .....	135
4.18.	VALVE Submenu – Configuring valve parameters .....	114	4.23.13.	SPEED - Message scrolling speed .....	135
4.18.1.	F.uAL - Defining valve function .....	115	4.23.14.	BACKL - Backlighting level.....	136
4.18.2.	KEY.MO - Enabling valve operation with keys .....	115	4.23.15.	QUICK - Quick configuration menu .....	136
4.18.3.	TRAVL - Valve actuator travel time .....	115	4.24.	LINRZ Submenu – Configuring custom linearization .....	137
4.18.4.	TIM.LO - Minimum power change for valve drive.....	115	4.24.1.	STP.xx - Value of step xx .....	138
4.18.5.	TIM.HI - Impulse mode setpoint .....	115	4.24.2.	MV.STA - Setting mV at start of scale .....	138
4.18.6.	TIM.ON - Minimum valve impulse time or ON time in		4.24.3.	MV.FUL - Setting mV at full scale .....	138
	impulse mode .....	116	4.24.4.	MV.50C - Setting mV at temperature of 50 °C.....	138
4.18.7.	TIM.OF - OFF time in impulse mode.....	116	4.25.	US.CAL Submenu – User calibrations .....	139
4.18.8.	DEAD.B - Deadzone symmetrical to setpoint.....	116	4.25.1.	U.CAL - Selecting the user calibration.....	140
4.19.	MODE Submenu – Configuring functioning mode.....	117	4.25.2.	FI.CAL - Resetting the factory calibration.....	140
4.19.1.	PID.G.N - Number of groups of control parameters	118	4.25.3.	C.LOW - Calibrating minimum current / voltage.....	140
4.19.2.	MA.AU - Defining transition from Manual to Automatic.	118	4.25.4.	C.HIGH - Calibrating maximum current / voltage.....	141
4.19.3.	AU.MA - Defining transition from Automatic to Manual.	118	4.25.5.	RTD.LO - Calibrating minimum resistance value .....	141
4.19.4.	LO.rE - Defining transition from remote SP to local SP.	118	4.25.6.	RTD.HI - Calibrating maximum resistance value .....	141
4.19.5.	On.OF - Enable software shutdown from keys.....	119	4.25.7.	HOURL - Setting hours .....	141
4.19.6.	MA.PL - Enabling manual power latch .....	119	4.25.8.	MIN - Setting minutes .....	141
4.19.7.	MAn.P - Enabling change of manual power value...	119	4.25.9.	SEC - Setting seconds.....	142
4.19.8.	dIG - Defining type of digital inputs .....	119	4.25.10.	dAY - Setting day of week .....	142
4.19.9.	S.PROG - Enable Simplified Programmer mode .....	119	4.25.11.	DATE - Setting day.....	142
4.19.10.	EN.EDI - Enable MENU CONFIGURATION.....	120	4.25.12.	Mont - Setting month.....	142
4.19.11.	ALRM.N - Number of alarms enabled.....	120	4.25.13.	YEAR - Setting year .....	142
4.19.12.	tMER - Enabling Timer function .....	120	4.25.14.	C.LO - Setting analog output minimum .....	143
4.19.13.	MUL.SP - Enabling Multiset function.....	120	4.25.15.	C.HIG - Setting analog output maximum .....	143
4.19.14.	SP.REM - Enabling the remote setpoint.....	121	4.26.	PASC0 - Setting level 0 password 0 .....	144
4.19.15.	SP.r.t - Defining absolute or deviation to remote setpoint ..	121	4.27.	PASC1 - Setting level 1 password 1 .....	144
4.19.16.	PROGR - Enabling the setpoint programmer .....	121	4.28.	PASC2 - Setting level 2 password 2 .....	144
4.19.17.	t.Pro - Setting the programmer base time .....	121	4.29.	FI.CFG - Entering the reset code .....	144
4.19.18.	ENERG - Enabling the energy counter function.....	122	<b>5. Examples and application notes.....</b>	<b>145</b>	
4.19.19.	T.SAMP - Main input sample time .....	122	5.1.	Heat/cool control application.....	145
4.19.20.	FREQZ - Defining power line frequency .....	122	5.1.1.	Connection diagram.....	145
4.20.	TIMER Submenu – Configuring timer parameters .....	123	5.1.2.	Quick configuration procedure for model 6140–D-R00-00000-1.....	146
4.20.1.	F.tiM - Selecting Timer function mode.....	124	5.2.	Heating control and current (CT) application .....	147
4.20.2.	St.St - Selecting the Start/Stop timer command.....	124	5.2.1.	Connection diagram.....	147
4.20.3.	S.S.t - Defining the Start/Stop timer command logic ....	124	5.2.2.	Quick configuration procedure for model 6140–D-R00-00100-1.....	148
4.20.4.	rESE - Selecting the Reset timer command .....	124	5.3.	Remote setpoint input.....	149
4.20.5.	rES.t - Defining the timer reset command logic.....	125	5.4.	4-point input correction.....	149
4.20.6.	BAND - Band for timer count.....	125	5.5.	Current inputs .....	149
4.20.7.	End - Selecting the function activated at end of count .	125	5.6.	Alarms .....	150
4.20.8.	TIMER - Timer value .....	125	5.6.1.	Generic alarms AL1...AL4 .....	150
4.20.9.	MSG.TM - Selecting the message assigned to the		5.6.2.	HB alarm .....	151
	active count .....	126	5.6.3.	HB alarm calibration .....	151
4.21.	ENERG Submenu - Configuring energy counter parameters ..	127	5.6.4.	LBA alarm .....	151
4.21.1.	ENERG - Selecting the output for energy calculation....	128	5.7.	Retransmission output .....	152
4.21.2.	V.LINE - Nominal line voltage.....	128	5.8.	Switching the software on/off .....	152
4.21.3.	P.LOAD - Nominal power of load .....	128	5.8.1.	How to switch it off.....	152
4.21.4.	E.COST - Nominal cost per kWh .....	128	5.8.2.	How to switch it on .....	152
4.22.	SERIA Submenu – Configuring serial communication .....	129	5.9.	Soft-Start.....	152
4.22.1.	CODE - Identification code.....	130	5.10.	Tuning.....	152
4.22.2.	KBAUD - Selecting communication speed.....	130	5.10.1.	Tuning actions.....	152
4.22.3.	PAR - Selecting parity .....	130	5.10.1.1.	<i>Influence of Proportional, Derivative and Integral actions on response of controlled process .....</i>	<i>152</i>

# CONTENTS

---

5.10.2.	Manual tuning .....	153	8.6.	Troubleshooting.....	178
5.10.3.	Self-Tuning .....	153	<b>9.</b>	<b>Technical data.....</b>	<b>179</b>
5.10.4.	Auto-Tuning.....	154	<b>10.</b>	<b>Order methods.....</b>	<b>187</b>
5.10.5.	Examples of tuning .....	154	10.1.	6140 & 4140 Controller.....	187
5.10.6.	Heat/Cool tuning with relative gain .....	154	<b>11.</b>	<b>Accessories .....</b>	<b>188</b>
5.11.	Timer .....	155			
5.11.1.	Start/Stop Timer.....	155			
5.11.2.	Stabilization timer .....	156			
5.11.3.	Start timer .....	156			
5.11.4.	Variables available for the user configuration menu .....	156			
5.12.	Multiset, setpoint gradient .....	157			
5.13.	Setpoint programmer .....	157			
5.13.1.	What is a program.....	157			
5.13.2.	Programmer functions .....	157			
5.13.3.	Programmer behavior .....	158			
5.13.4.	Program examples.....	158			
5.13.4.1.	ONE STEP program.....	158			
5.13.4.2.	ONE STEP program.....	158			
5.13.4.3.	Program with assigned events.....	158			
5.13.4.4.	Program with HBB (hold back band) function .....	160			
5.13.5.	Fast simulation of program .....	160			
5.13.6.	Controlling the program from the.....				
	.....				
	.....				
	keypad .....	160			
5.13.7.	Programmer Reset mode.....	160			
5.13.8.	Restart with step search .....	160			
5.13.9.	Simplified Programmer Mode.....	161			
5.14.	Managing motorized valves .....	162			
5.14.1.	Valve control parameters .....	162			
5.14.2.	Valve control modes.....	163			
5.15.	Energy counter .....	163			
5.16.	Logic Operations.....	164			
5.16.1.	Function blocks.....	164			
5.16.2.	Groups of variables.....	164			
5.16.3.	Programming Function Block .....	166			
5.16.3.1.	Configuration page .....	166			
5.16.3.2.	Enabling the function block and selecting the type of functional logic.....	167			
5.16.3.3.	Configuring input variables .....	167			
5.17.	Instrument menu set-up.....	168			
5.16.3.4.	Configuring the output.....	168			
5.16.3.5.	Configuring delays.....	168			
<b>6.</b>	<b>Programming with pc.....</b>	<b>171</b>			
6.1.	Controller-PC connection.....	171			
6.2.	Programming Tool .....	171			
6.2.1.	C-PWR.....	171			
6.2.1.1.	System requirements.....	171			
<b>7.</b>	<b>Operator guide.....</b>	<b>173</b>			
7.1.	Displays and keys .....	173			
7.1.1.	Navigating the menus .....	173			
7.2.	Power-on.....	173			
7.3.	Operation as controller.....	173			
7.4.	Operation as programmer.....	174			
7.4.1.	Activating the programmer .....	174			
7.4.2.	Display messages.....	174			
7.5.	Errors during operation .....	174			
7.6.	Configuration (User menu) .....	175			
<b>8.</b>	<b>Maintenance .....</b>	<b>177</b>			
8.1.	Replacing the controller .....	177			
8.2.	Replacing the gasket.....	177			
8.3.	Cloning the configuration .....	177			
8.4.	Cleaning .....	177			
8.5.	Disposal .....	178			

# INTRODUCTION

## Device data

In the space below, write the order code and other plate data shown on the label attached to the outside of the controller.

If you need technical assistance, this information must be given to Chromalox Customer Service.

Serial number	<b>SN</b>	
Finished product code	<b>CODE</b>	
Order code	<b>TYPE</b>	
Supply voltage	<b>SUPPLY</b>	
Firmware version	<b>VERS.</b>	

## Warnings and safety

Make sure that you always have the latest version of this manual, downloadable at no cost from Chromalox's website ([www.chromalox.com](http://www.chromalox.com)).

The devices described in this manual must be installed by trained personnel in conformity to current laws and regulations, following all of the instructions in this manual.

Installers and/or maintenance personnel **MUST** read this manual and scrupulously follow all of the instructions contained herein and in the attachments.

Chromalox will not be liable for any damage/harm caused to persons and/or property, or to the device itself, if all of such instructions are not followed.

This manual must always be available to people who use or work on the devices described herein.

Before using the controllers, the operator must be adequately instructed with regard to operating, emergency, diagnostics, and maintenance procedures.

If the controllers are used in applications with risk of harm to persons or damage to machines or materials, auxiliary alarm devices must be installed.

It is advisable to provide the possibility, during normal operation, of checking whether any alarms have tripped.

**DO NOT** touch the terminals when the device is powered.

## INTRODUCTION

### Typographical conventions used in this manual

Pay attention when you see these symbols in the manual.



Indicates very important information on correct product function or on safety, or an instruction that **MUST** be followed.



Indicates a suggestion that could be useful for better use of the device



Indicates risk for the safety of the installer or user due to the presence of high voltage.



Indicates a reference to other technical documents that can be downloaded from [www.chromalox.com](http://www.chromalox.com).



Indicates a point to which the reader's attention is called.

## Glossary

<b>4...20 mA</b>	Current used as signal transmitted by certain sensors or in a specific way to control a device, such as a motorized valve.	<b>PID</b>	Acronym for Proportional-Integration-Differentiation, indicating a system with negative feedback, i.e., a device that acquires a value from a process in input, compares it to a reference value, and uses the difference (error) to calculate the value of the controller output variable, which is the variable that controls the process. The output is controlled based on the current value of the error (proportional action), on a set of previous error values (integral action), and on the speed of change of the error value (derivative action).
<b>Alarm</b>	Output that trips when a certain condition is reached, for example, a defined temperature	<b>Pt100</b>	A commonly used temperature measurement device. At 0°C its resistance is 100 ohm, and at room temperature about 106 ohm. The Pt100 can be tested for galvanic continuity and normal extension cables can be used.
<b>Auto Tune</b>	Function that lets you calculate and easily set the P, I and D parameters thanks to the controller's self-learning.	<b>PV</b>	Acronym for Process Value, i.e., the value that the process variable (temperature, valve opening, etc.) has at that moment.
<b>Cool</b>	Control used for cooling.	<b>Solid state relay</b>	Also known as SSR, this is a relay designed specifically for frequent switching. It has no moving parts or mechanical contacts, but may still break or short circuit. This type of relay is often used in temperature control systems such as PID.
<b>Heat/Cool</b>	Control used for both heating and cooling (requires two control outputs).	<b>Sensor</b>	Device that translates physical phenomena (such as change in resistance based on temperature) into electrical signals that can be acquired and processed by the controller
<b>Heat</b>	Control used for heating.	<b>Setpoint</b>	Set value (see SV).
<b>Hysteresis</b>	When, at a precise moment, the value of the controlled quantity depends not only on another reference quantity but also on the values that the controlled quantity had previously, there is hysteresis. Hysteresis can therefore be considered inertia that influences the control system, causing variable delays between the change of the reference quantity and the change of the controlled quantity.	<b>SV</b>	Acronym for Set Value, i.e., the value that the process variable (temperature, valve opening, etc.) has to reach and maintain.
<b>ON-OFF</b>	Control procedure based on activation and deactivation of the output. For heating, the output stays on until PV is less than SV by a certain quantity (offset), and then stays off until PV is not greater than SV by the same quantity (or different quantity, depending on controller configuration). For cooling, the output stays on until PV > SV - offset and stays off until PV < SV + offset. This type of control is not intelligent, does not consider noise, and is not very accurate, but ensures a limited number of switchings of the output.	<b>Thermocouple</b>	Sensor that transmits an electrical signal of a few millivolts. Cannot be tested for galvanic continuity. It needs specially designed extension cables
<b>Overshoot</b>	Situation in which PV exceeds SV because the control action stopped too late. The ON OFF controls have an overshoot greater than the PID controls.		

<b>Undershoot</b>	Situation in which PV does not reach SV because the control action stopped too soon. The ON OFF controls have an undershoot greater than the PID controls.
<b>Control output</b>	Output that controls the process and is switched on and off as needed.

---

## Disclaimer

Although all of the information in this manual has been carefully checked, Chromalox assumes no liability regarding the presence of any errors or regarding damage to property and/or harm to individuals due to any improper use of this manual

Chromalox also reserves the right to change the contents and form of this manual, as well as the characteristics of the devices described herein, at any time and without notice.

The technical data and performance levels specified in this manual are to be considered a guide for the user in order to determine the device's suitability for a defined use, and do not constitute a guarantee.

They may be the result of test conditions at Chromalox, and the user must compare them to his/her real application requirements.

Under no circumstances will Chromalox be liable for any damage to property and/or harm to individuals due to tampering, incorrect or improper use, or use not conforming to the characteristics of the controller and to the instructions contained in this manual.

---

## Copyright

This manual and its attachments may be freely reproduced provided its contents are not changed in any way and provided every copy includes the above Disclaimer and the statement of ownership of Chromalox.

This manual may make reference to or reproduce trademarks and logos of third parties. Chromalox acknowledges such parties' ownership of these trademarks and logos.



# 1. GENERAL DESCRIPTION

## 1.1. Profile



6140



4140

The 6140 and 4140 controllers are a family of devices designed to control temperature in industrial processes and to manage the positioning (without feedback) of motorized valves.

The 3 devices have the same main characteristics and the same range of functions. They differ in size (1/16 and 1/4 DIN), the amount of information shown on the display, and the maximum number of digital inputs.

The displays show the process and setpoint values, plus multilingual scrolling messages for diagnostics, alarms and process state.

On models 4140, a segmented bar graph shows percentages of power, delivered current or valve position.

Configuration/local operation is done with keys (4 on the 6140, 6 on the 4140), to which dual-function LEDs are associated: feedback for pressed key and guide for permitted operations.

Commissioning is simplified by guided configuration for manual-free programming, with just a few indispensable parameters accompanied by inline help messages.

The configuration can be cloned among controllers without having to switch on the power supply thanks to the Zapper, a battery-operated portable mini-configurator (to be ordered separately).

With C-PWR software and PC, you can program the extended configuration, create work recipes and update the firmware without having to switch on the controllers.

Thanks to the Smart Configurator function, you obtain the required parameter recipe by answering a few simple questions.

The initial parameters can always be reset, both from the keypad and from the C-PWR software.

The devices offer complete diagnostics (broken or incorrect connection of sensor, total or partial load break, off-scale of variables and control loop faults), operation count, settable alarm limits (useful for scheduling preventive maintenance), and an internal energy counter to totalize energy consumption and cost to achieve continuous control.

Sixteen AND, OR and Timer Function Blocks let you create customizable logic sequences for complete and flexible machine control.

The controller's HW resources are exploited completely, without any need for external devices such as timers and small PLCs.

Tuning is performed via advanced algorithms that ensure stable and accurate adjustments, even with critical or very fast heating systems, and that engage automatically when necessary.

Models with twelve ramp and hold steps, groupable in four programs, with enable inputs and event outputs, are available for applications with setpoint profiles.

The controller can be configured directly with the keys or graphically via C-PWR software.

Maintenance of the system in which the device is installed is made easier by the ability to replace the controller at any time simply by removing it from the faceplate.

No additional steps are needed.

## 1. GENERAL DESCRIPTION

---

### 1.2. Differences among models

---

	6140	4140
Display dimensions	35 × 30 mm	83 × 68 mm
PV display	4 digit, 7 seg., H = 17 mm	4 digit, 7 seg., H = 23 mm
SV display	5 digit, 14 seg., H = 7 mm	4 digit, 7 seg., H = 11 mm
Display F	n/a	7 digit, 14 seg., H = 9 mm
Bargraph	n/a	11 segments
Keys	4	6
Max. digital inputs	3	5
Power dissipation	5 W	10 W
Dimensions	48 × 48 mm (1/16 DIN)	96 × 96 mm (1/4 DIN)
Weight	0,16 kg	0,35 kg

n/a = not available

## 1.3. 6140 Controller

### Main features

- Operator interface with large LCD Display, customizable, with choice of colors
- Scrolling diagnostics messages, configurable, in the selected language
- Easy, guided configuration, copy/paste parameters even with power off
- Preventive maintenance with energy counters (kWh) and load switching
- 16 function block applications
- Timer, setpoint and algorithm programmer for controlling motorized valves
- Advanced tuning of control parameters
- Different password levels
- Universal input configurable for thermocouples, resistance thermometers, linear inputs
- Input from remote setpoint
- Relay, logic, isolated analog outputs
- Up to two TA inputs for interrupted load diagnostics
- RS485 serial communication in Modbus RTU
- Removable faceplate for immediate replacement
- Accuracy 0.2%, sampling time 60 ms

### 1.3.1. Display and keys



Figure 1 - Description of display and keys

1. Temperature unit of measurement or number of program running.
2. State of outputs OUT1, OU2, OUT3, OUT4.
3. Controller function states:
  - RUN = setpoint programmer active;
  - $\_/-$  = setpoint ramp active;
  - TUN = PID parameters tuning active;
  - MAN = manual/automatic (off = automatic control, on = manual control);
  - REM = remote setpoint enabled;
  - SP1/2 = setpoint active (off = setpoint 1, on = setpoint 2).
4. Work mode key (manual/automatic) in standard mode. A function can be assigned via parameter but1. The key is active only when the display shows the process variable
5. Up/down keys: raise/lower the value of the parameter displayed on the SV or PV display.
6. F key: lets you navigate among controller menus and parameters. Confirms the parameter value and selects the next parameter.
7. Key pressed signals.
8. SV display: setpoint value, description of parameters, diagnostics and alarm messages. Configurable with parameter dS.SP (default = setpoint).
9. PV display: process variable, parameter values.

# 1. GENERAL DESCRIPTION

## 1.3.2. Drilling dimensions and templates

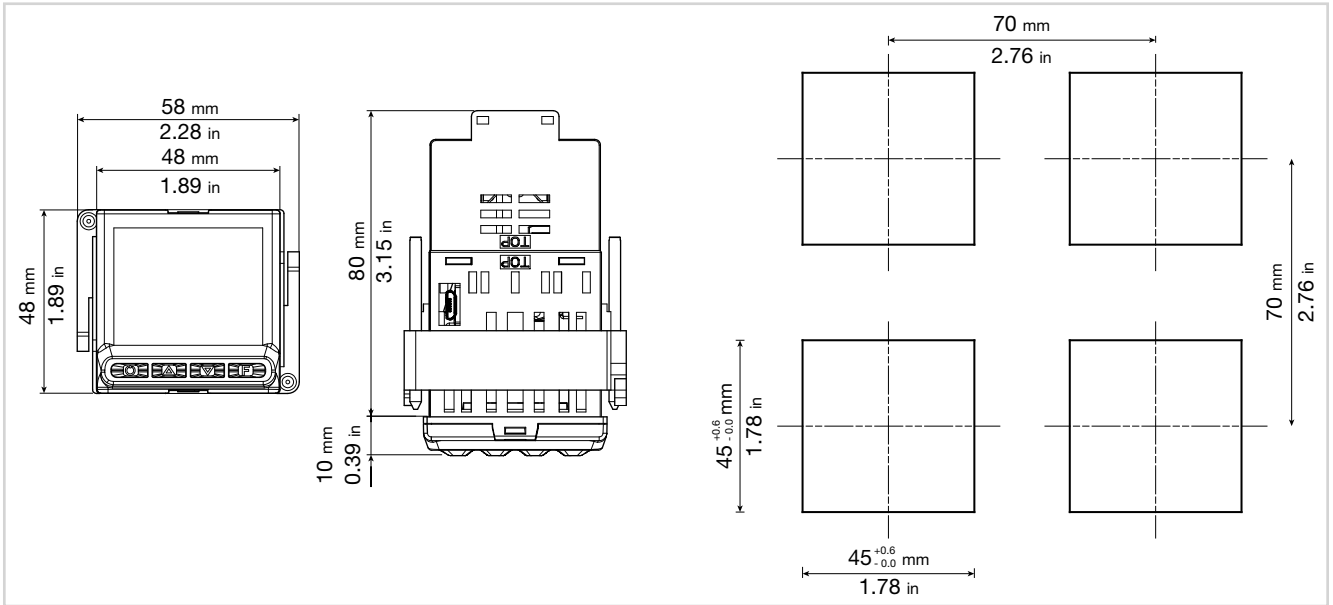

Figure 2 - 6140 drilling dimensions and templates





## 1.5. 4140 Controller

### Main features

- Operator interface with large LCD Display, customizable, with choice of colors
- Scrolling diagnostics messages, configurable, in the selected language
- Easy, guided configuration, copy/paste parameters even with power off
- Preventive maintenance with energy counters (kWh) and load switching
- 16 function block applications
- Timer, setpoint and algorithm programmer for controlling motorized valves
- Advanced tuning of control parameters
- Different password levels
- Universal input configurable for thermocouples, resistance thermometers, linear inputs
- Input from remote setpoint
- Relay, logic, isolated analog outputs
- Up to two TA inputs for interrupted load diagnostics
- RS485 serial communication in Modbus RTU
- Removable faceplate for immediate replacement
- Accuracy 0.2%, sampling time 60 ms

### 1.5.1. Display and keys

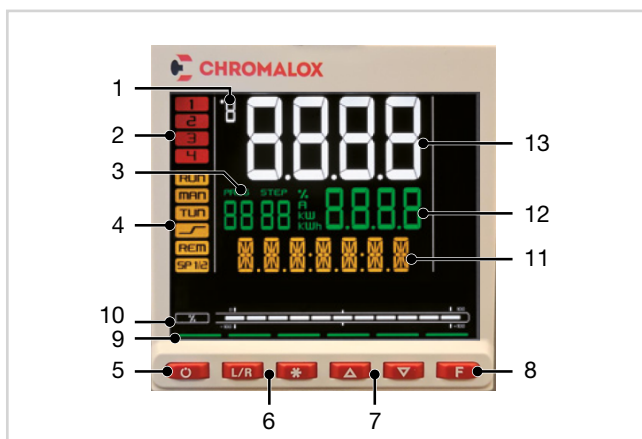

Figure 5 - Description of display and keys

1. Temperature unit of measurement or number of program running.
2. State of outputs OUT1, OU2, OUT3, OUT4.
3. Displays program number, step number, unit of measurement (% , A, kW, kWh).
4. Controller function states:
  - RUN = setpoint programmer active;
  - \_/- = setpoint ramp active;
  - TUN = PID parameters tuning active;
  - MAN = manual/automatic (off = automatic control, on = manual control);
  - REM = remote setpoint enabled;
  - SP1/2 = setpoint active (off = setpoint 1, on = setpoint 2).
5. Work mode key (manual/automatic) in standard mode. A function can be assigned via parameter but1. The key is active only when the display shows the process variable.
6. Key function configurable with parameters but2 and but3. The keys are active only when the display shows the process variable.
7. Up/down keys: raise/lower the value of the parameter displayed on the SV or PV display.
8. F key: lets you navigate among controller menus and parameters. Confirms the parameter value and selects the next parameter.
9. Key pressed signals.
10. Displays percentage of power or current, configurable with parameter bArG.
11. F display: parameters, diagnostics and alarm messages. Configurable with parameter dS.F (default = setpoint).
12. SV display: parameter values. Configurable with parameter dS.SP (default = setpoint).
13. PV display: process variable.

# 1. GENERAL DESCRIPTION

## 1.5.2. Drilling dimensions and templates

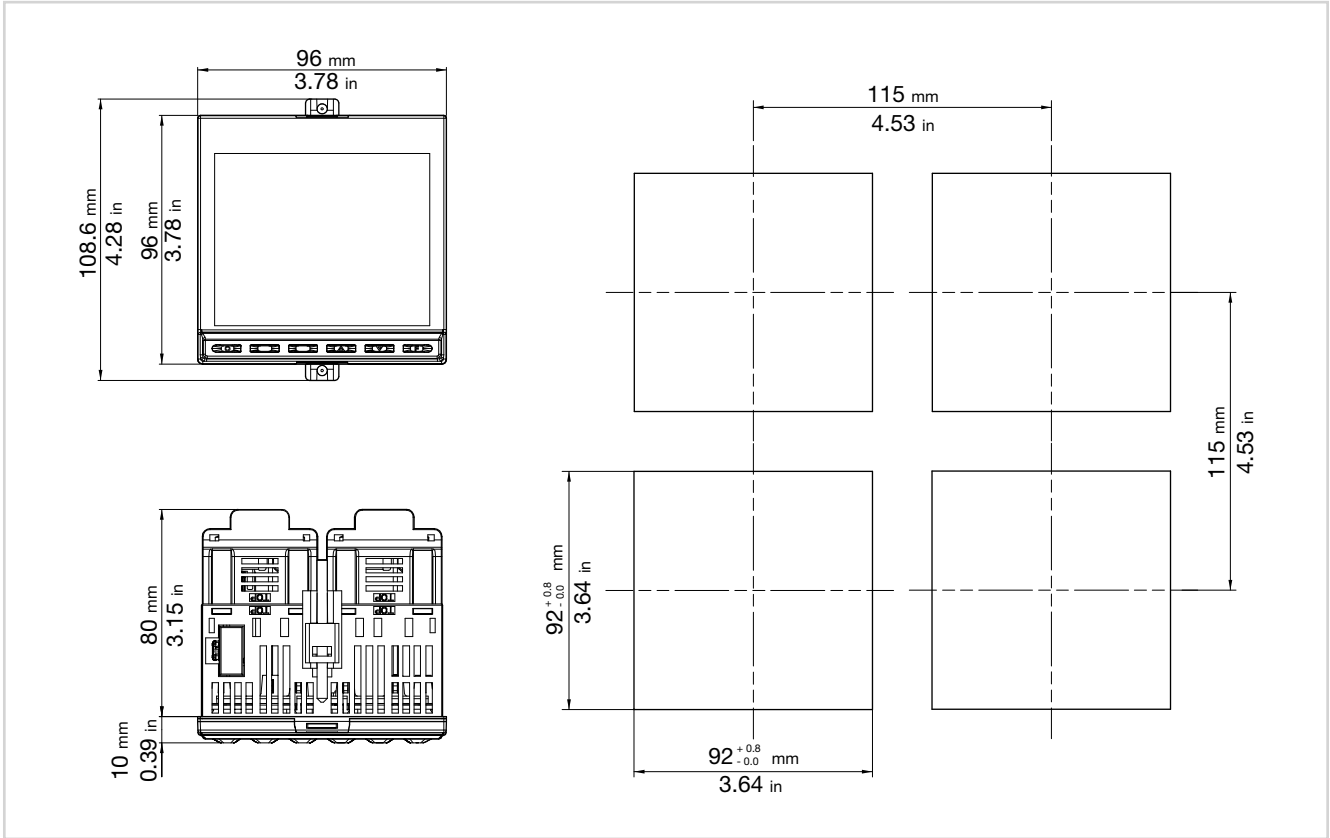

Figure 6 - 4140 drilling dimensions and templates

## 2. INSTALLATION



**Attention!** The devices described in this manual must be installed by trained personnel in conformity to current laws and regulations, following all of the instructions in this manual.

Before installing, check that the controller is in perfect condition and was not damaged in shipment. Make sure that the package contains all of the accessories listed on the accompanying document, especially the gasket and the fastening brackets.

Check that the order code matches the configuration required for the intended application (supply voltage, number and type of inputs and outputs). See Chapter 10 - Ordering code - to check the configuration corresponding to each order code.



**Attention!** If even one of the requirements mentioned above (trained technician in, device in perfect condition, correct configuration) is not satisfied, interrupt the installation and contact your Chromalox dealer or Chromalox Customer Service.

### 2.1. Mounting the controller

#### 2.1.1. General installation rules

The controller is designed for permanent indoor installation. It must be mounted on electrical panels or on panels controlling machines or production process plants that are able to protect the exposed terminals on the rear of the controller.



**Attention!** DO NOT install the controller in a potentially inflammable or explosive atmosphere. It can be connected to elements that work in such atmospheres only by means of appropriate interfaces that conform to safety regulations in force in the country of installation.



**Attention!** the controller is used in applications with risk of harm/damage to persons/property, it MUST be connected to dedicated alarm devices. It is advisable to provide the possibility, during normal functioning of the controller and of the system or equipment that it controls, of checking whether any alarms have tripped.

The controller must be installed in a location that is not subject to sudden temperature changes or to freezing or condensation, and no corrosive gases must be present.

The controller can work in Pollution Degree 2 environments (presence of non-conductive dust, only temporarily conductive due to possible condensation). Do not allow scrap or metal particles from machining or condensation products to reach the device.

The controller is sensitive to strong electromagnetic fields. Do not position it near radio devices or other equipment that may generate electromagnetic fields, such as power contactors, relays, thyristor power units (especially phase angle), motors, solenoids, transformers, high-frequency welders, etc.

#### 2.1.2. Drilling dimensions

For correct installation, respect the dimensions of each hole and the distance between adjacent holes shown in the figures for each model ("Figure 2 – 6140 drilling dimensions and templates" on page 14, "Figure 6 – 4140 drilling dimensions and templates" on page 18).



**Attention!** The support on which the operator panel is mounted must:

- be sufficiently rigid and robust to support the device without bending during use;
- be from 1 to 4 mm thick to allow the device to be fastened with the supplied bracket.

#### 2.1.3. Protection against infiltration of dust and water

The front of the controller has an IP65 protection index, so the device can be installed without problems in rooms that are very dusty or subject to splashing water provided:

- the housing in which the device is inserted is dust-tight and watertight;
- the support on which the device is installed is perfectly smooth and without undulations on the front;
- the hole on the support scrupulously respects the specified drilling dimensions;
- the device is fully tightened to the support to ensure that the gasket inserted between the device and the panel is watertight



**Attention!** If not adequately protected, the controller has an IP20 protection index (rear container and terminal board).

## 2. INSTALLATION

### 2.1.4. Vibrations

The controller can support vibrations from 10 to 55 Hz, 20 m/s<sup>2</sup>, in all directions (X, Y and Z).

If the device is mounted on a support that exceeds these limits, it is advisable to provide a suspension system to reduce vibrations.

### 2.1.5. Minimum space for ventilation

The temperature in the housing containing the controller must NEVER exceed 55°C. NEVER block the ventilation slits.



**Advice.** The lower the temperature in which the device works, the longer the life of its electronic components.



**Attention!** Forced cooling (for example, with a fan) of the rear of the controller may cause measurement errors.

### 2.1.6. Positioning

The controller must be positioned so that the display is not subject to direct sunlight or to very strong sources of light. If necessary, filter direct light, for example, with a reflective screen.

The controller must be tilted between 30° and 120°, as shown in the figure.

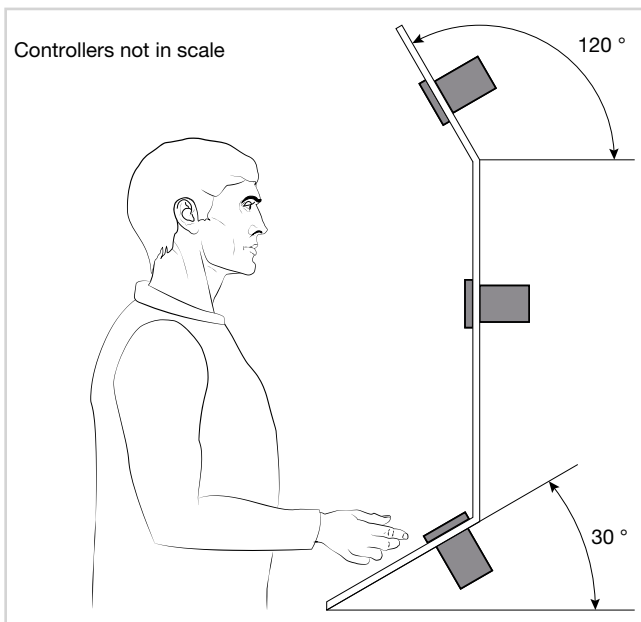

Figure 7 - Positioning the controller

### 2.1.7. Fastening to the panel

1. Insert the die-cut rubber gasket between the controller and the panel. The gasket (supplied) is indispensable for ensuring the declared protection index of the faceplate.
2. Insert the device into the hole previously made on the panel.
3. Place the supplied bracket(s) onto the rear of the controller.
4. Tighten the screws to fasten the device to the panel. The tightening torque must be between 0,3 and 0,4 N m.

The following figures show how to fasten the three controller models.

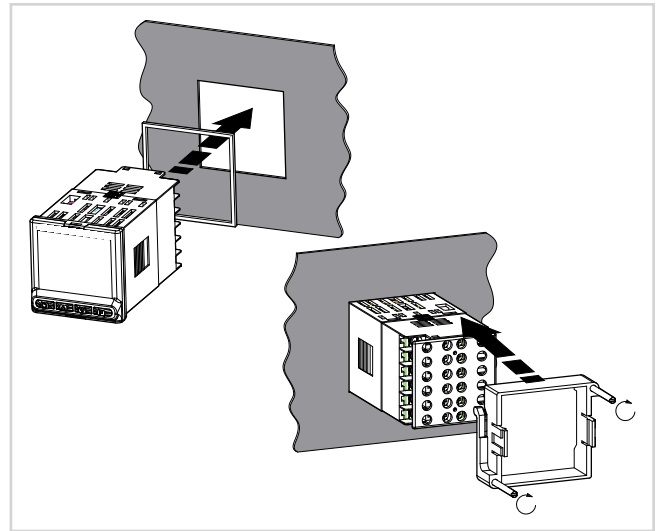

Figure 8 - Fastening the 6140

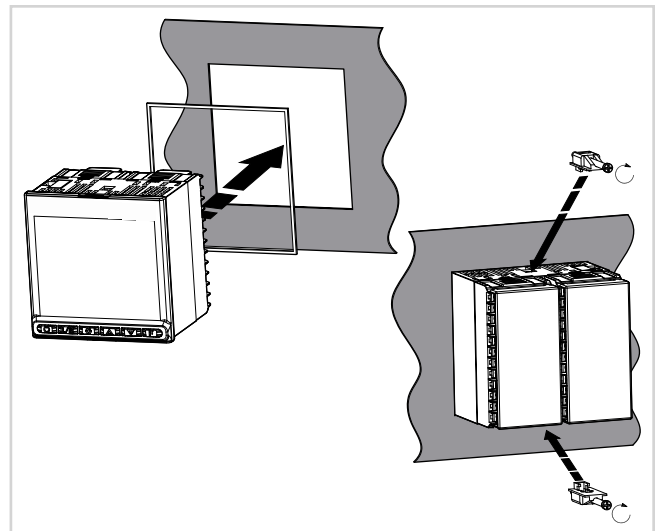

Figure 10 - Fastening the 4140

## 2.2. Connections



**Attention!** Failure to follow the instructions in this section may cause problems in electrical safety and electromagnetic compatibility, in addition to voiding the warranty.

### 2.2.1. General rules for connections

1. Connected external circuits must have double isolation.
2. In case of shielded cables, the shield must be grounded at a single point, possibly near the controller.
3. Input cables must be physically separated from power cables, output cables, and power connections.
4. Do not connect unused terminals.
5. Tighten the terminals without forcing. Loose terminals may cause sparks and fires.  
The recommended tightening torque is 0.5 Nm.
6. When making connections, respect polarity where required.
7. Do not bend or twist the cables beyond the limits specified by the manufacturers.
8. After connecting the cables, apply the transparent cover to protect the terminals.  
The terminal teeth limit and define the correct direction for applying the cover.

### 2.2.2. Electromagnetic compatibility (EMC)

For electromagnetic conformity, the strictest general rules have been applied, using the following test configuration:

Connection	Cable section	Length
Power supply	1 mm <sup>2</sup>	1 m
Relay	1 mm <sup>2</sup>	3,5 m
Serial port	0,35 mm <sup>2</sup>	3,5 m
Thermocouple	0,8 mm <sup>2</sup>	5 m compensated
Potentiometer, linear, "PT100" resistance thermometer	1 mm <sup>2</sup>	3 m
Analog retransmission output	1 mm <sup>2</sup>	3,5 m
Digital input/outputs	1 mm <sup>2</sup>	3,5 m

### 2.2.3. Cables

Always use cables appropriate for the voltage and current limits specified in the Technical Characteristics.

Use copper cables with 60/75°C insulation.  
Use twisted and shielded cables for non-power connections.

The controller's terminal board has screw terminals (M3) that accept stripped cables and crimped terminals for a tightening torque of 0.5 N m.  
Two ring or crimped fork terminals can be connected on each terminal

The following table shows the characteristics of the cables and terminals that can be used.

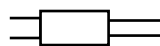
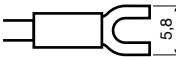
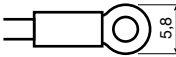
Cable / terminal	Cable / terminal section	Terminal size
Rigid cable	0,2...2,5 mm <sup>2</sup> (24...14 AWG)	
Twisted	0,2...2,5 mm <sup>2</sup> (24...14 AWG)	
 Tag terminal (to be crimped)	0,25...2,5 mm <sup>2</sup> (23...14 AWG)	
 Fork terminal (to be crimped)		5,8 mm max
 Ring terminal (to be crimped)		5,8 mm max



**Attention!** Anchor the cables, at least in pairs, so that mechanical stresses do not discharge on the terminal connections.

### 2.2.4. Power supply



**Attention!** Before powering the controller, make sure that the supply voltage matches the one shown on the controller data plate.

Because the controller does not have a switch, a bipolar switch with fuse must be inserted upline. The switch, or isolator, must be positioned in the immediate vicinity of the device and must be easily reached by the operator.  
A single switch can control multiple controllers.

The controller must be powered by a line separated from the one used for electromechanical power devices (relays, contactors, solenoids, etc).

It is advisable to install a ferrite core on the power line, as close as possible to the device, to limit the controller's susceptibility to electromagnetic noise.

If the controller's power line is heavily disturbed by the switching of thyristor power units or by motors, it is advisable to use an isolation transformer only for the controller, grounding the shield.

Use appropriate line filters in the vicinity of high-frequency generators or arc welders.  
Use a voltage stabilizer if there are wide shifts in line voltage.

20...27 VAC/VDC models must be powered by a class II or low-voltage limited-energy source.

The power supply must use a line separated from the one used for electromechanical power devices, and low-voltage power cables must run along a path separated from the system or machine power cables.

## 2. INSTALLATION



**Attention!** Make sure the ground connection is efficient. Absent or inefficient grounding can make the device unstable due to excessive noise.

Specifically, check that:

- voltage between mass and ground is  $< 1\text{ V}$ ;
- resistance is  $< 6\ \Omega$ .



**Attention!** If the controller is connected to devices that are NOT electrically isolated (such as thermocouples), ground with a specific conductor to prevent grounding directly through the machine structure.

### 2.2.5. Connecting inputs and outputs

The controller's input and output lines must be separated from the power line.

To prevent noise, the controller's input and output cables must be kept away from the power cables (high voltages or high currents).

The input and output cables and the power cables must not be placed parallel to one another.

Use shielded cables or separate cable trays.

To connect the output to an inductive load (relay, contactor, electrovalve, motor, fan, solenoid, etc.) that works in AC, mount a snubber, i.e., an RC group (resistor and condenser in series) placed parallel to the load. Installing this filter lengthens the life of the relays.

NOTE: All condensers must conform to VDE (class X2) standards and support voltage  $\geq 220\text{ VAC}$ .

The power of the resistor must be  $\geq 2\text{ W}$ .

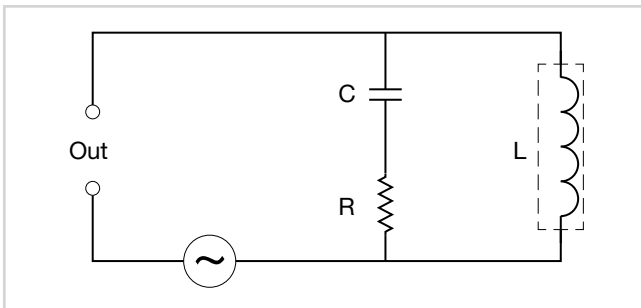

Figure 11 - Snubber connection diagram (AC)

For inductive loads that work in DC, mount a 1N4007 diode parallel to the coil.

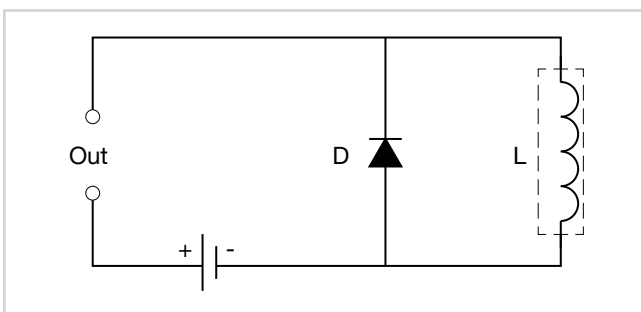
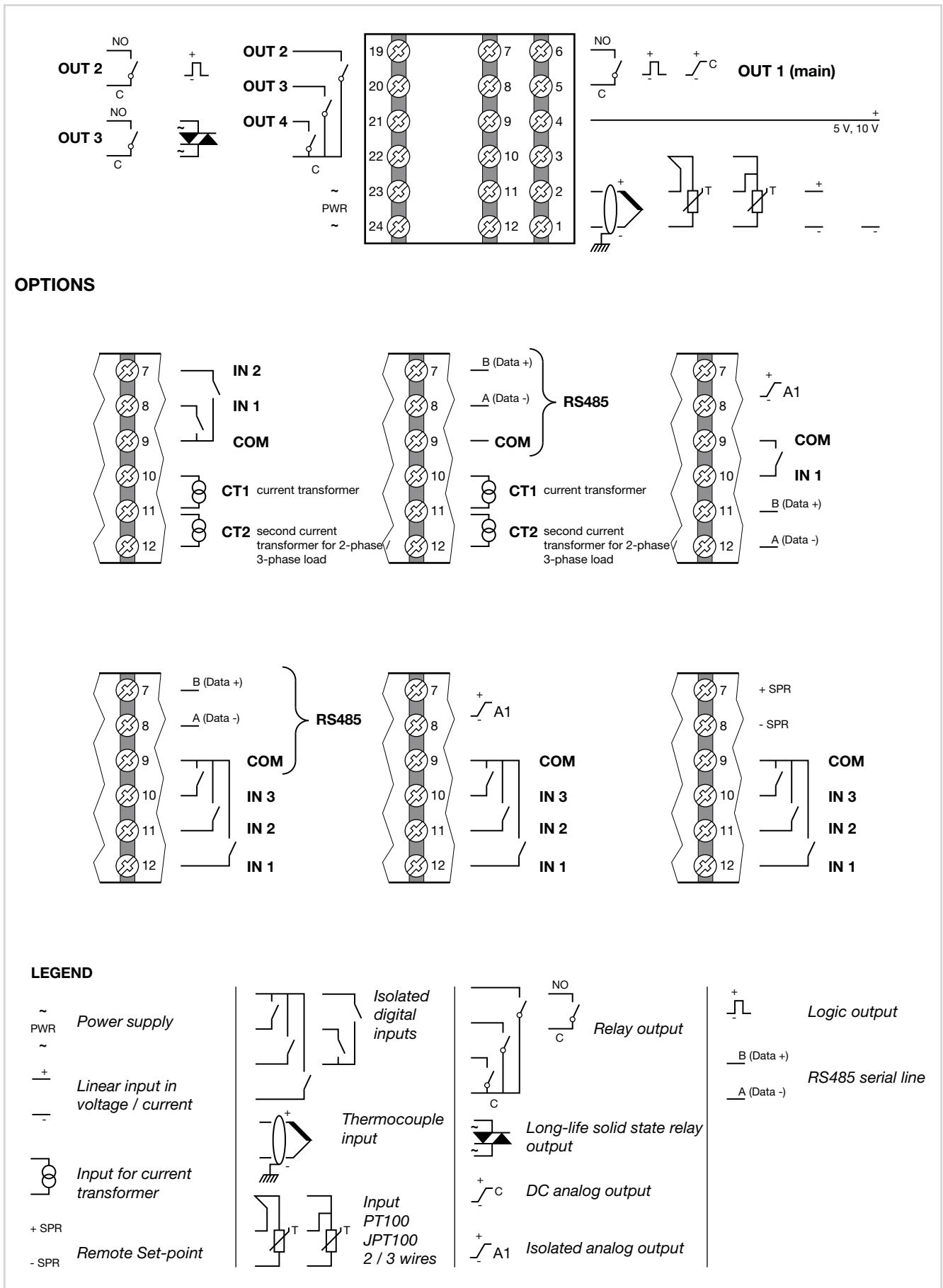

Figure 12 - Snubber connection diagram (DC)

The filters must be connected as close as possible to the controller.

### 2.3. 6140 connection diagrams

#### 2.3.1. General diagram



## 2. INSTALLATION

### 2.3.2. Power supply

**Power supply:**

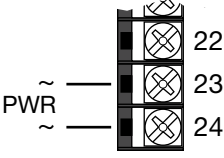

Standard: 100...240VAC/VDC  $\pm$  10%  
50/60Hz, max 5 VA

Optional: 20...27VAC/VDC  $\pm$  10%  
50/60Hz, max 5 VA

### 2.3.3. Inputs

**TC inputs**

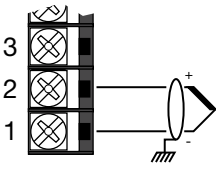

Available thermocouples:  
J, K, R, S, T, C, D, B, E, L, L-GOST,  
U, G, N, Pt20Rh-Pt4020Rh)  
ITS90 or custom linearization

Respect polarity  
For extensions, use a compensated  
cable suitable for the type of TC used.

**Linear input (V, I)**

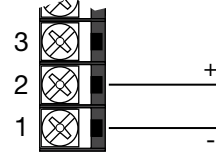

Linear input voltage  
60 mV ( $R_i > 70 \text{ k}\Omega$ )  
1 V ( $R_i > 15 \text{ k}\Omega$ )

Linear input in direct current  
0/4...20 mA,  $R_i = 50 \Omega$

**Linear input (V)**

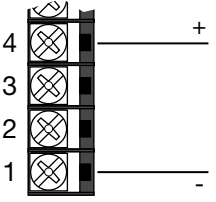

Linear input in direct voltage  
5V, 10 V ( $R_i > 30 \text{ k}\Omega$ )

**Input PT100/JPT100 - 2-wires connection**

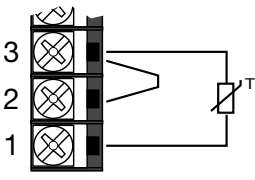

**Attention:**  
with this type of connection the line  
resistance can introduce measure-  
ment error, we recommend that  
you use wires of adequate.

### Input PT100/JPT100 - 3-wires connection

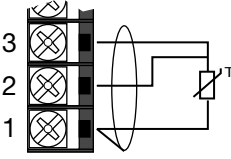

**Attention:**  
with this type of connection the  
line resistance can introduce me-  
asurement error, we recommend  
that you use wires of adequate  
screen.  
The resistance of the three wires  
must be equal, the line resistance  
must be less than 20 ohm.

### 2.3.4. Outputs

Characteristics of outputs are defined when the controller is ordered.

#### Output Out 1 - 5 A relay

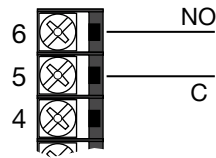

5 A Relay  
250 VAC

#### Output Out 1 - logic

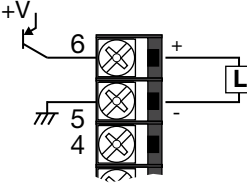

Logic 24 V  
(10 V to 20 mA)

#### Output Out 1 - continuous

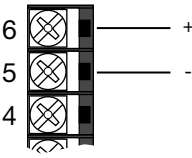

4...20 mA continuous  
 $R_{out} < 500$

#### Output Out 2 - 5 A relay

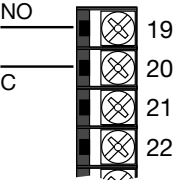

5 A Relay  
250 VAC

**Output Out 2 – logic**

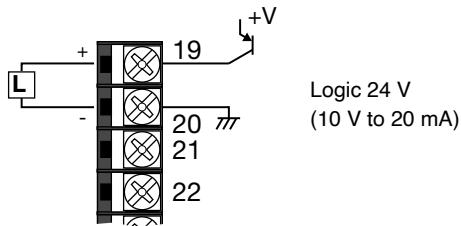

**Option 1**

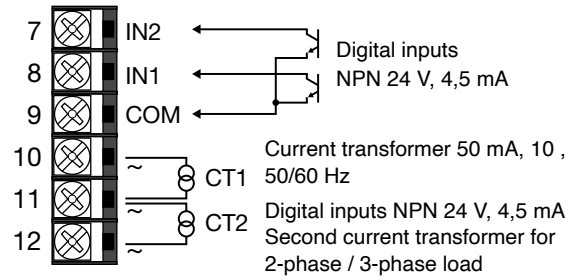

**Output Out 3 – 5 A relay**

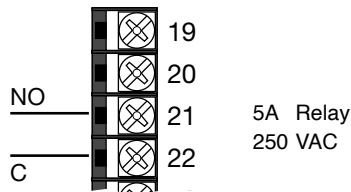

**Option 1**

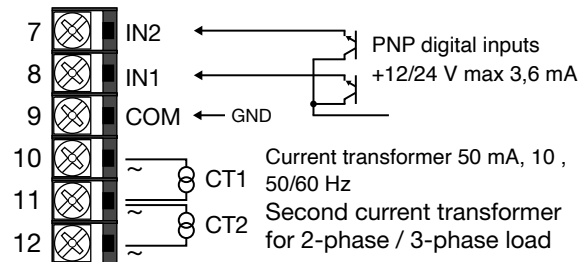

**Output Out 3 – Triac**

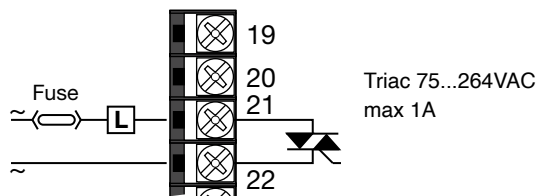

**Option 2**

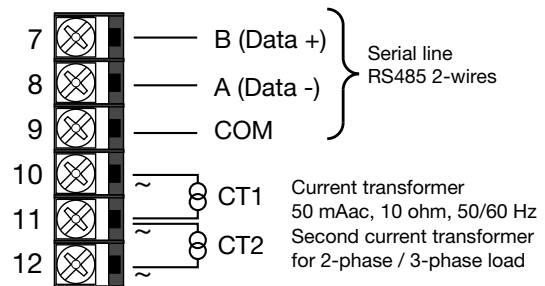

**Output Out 4 – 5 A relay**

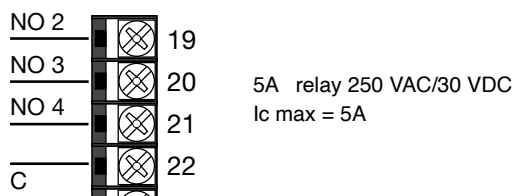

**Option 3**

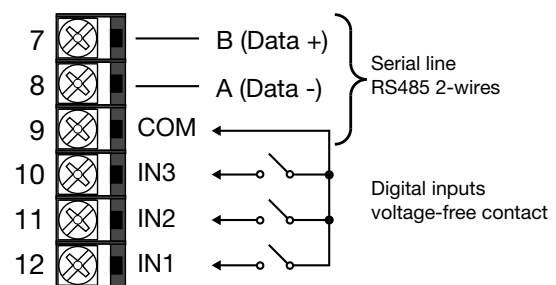

**2.3.5. Options**

Characteristics of optional inputs and outputs are defined when the controller is ordered.

**Option 1**

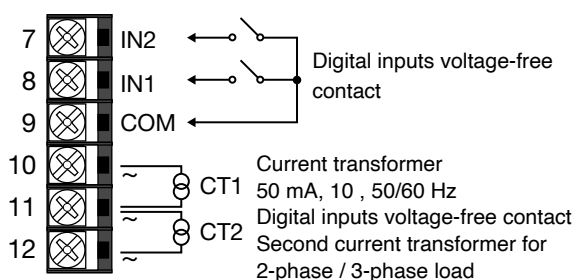

**Option 3**

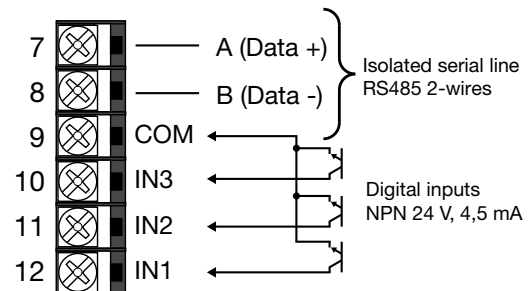

## 2. INSTALLATION

**Option 3**

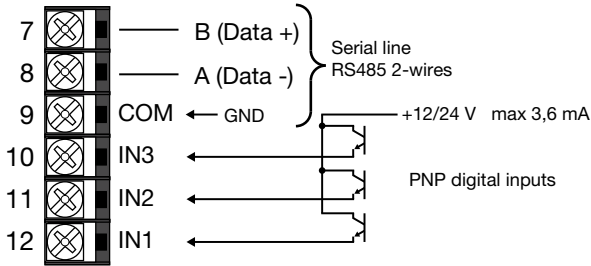

**Option 5**

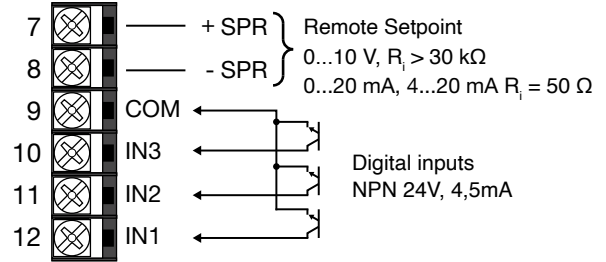

**Option 4**

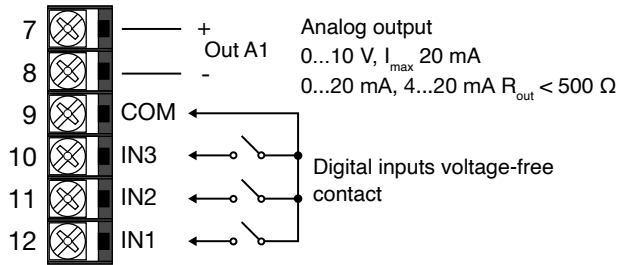

**Option 5**

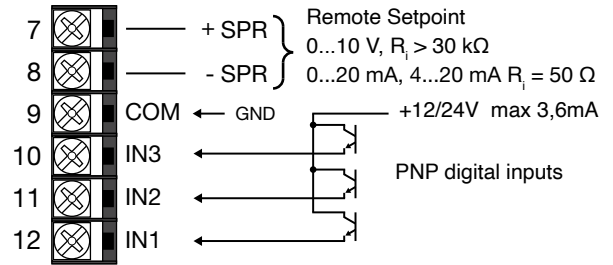

**Option 4**

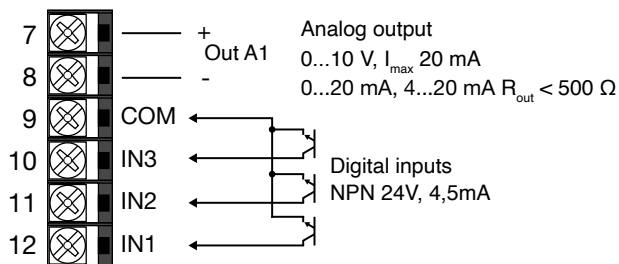

**Option 6**

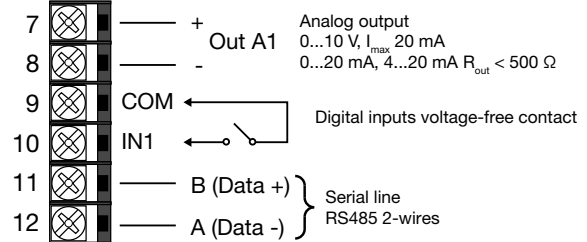

**Option 4**

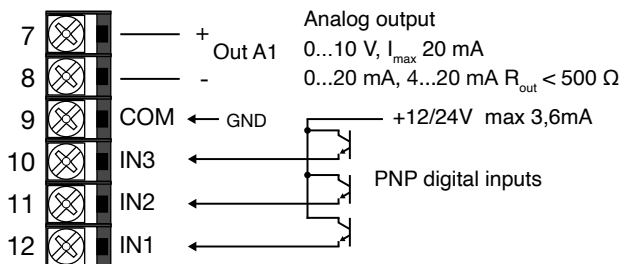

**Option 6**

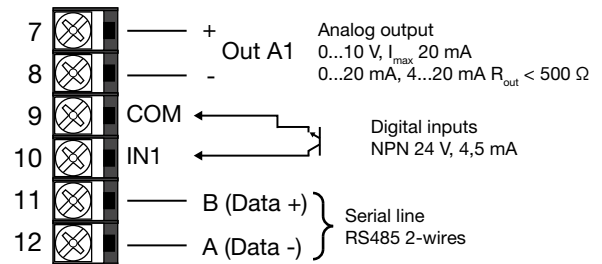

**Option 5**

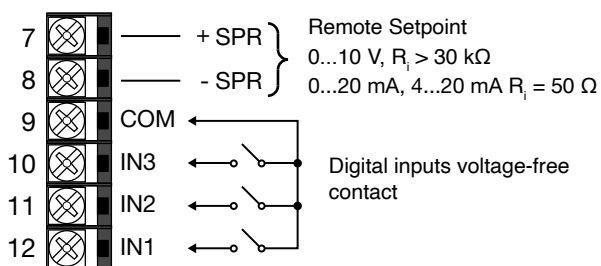

**Option 6**

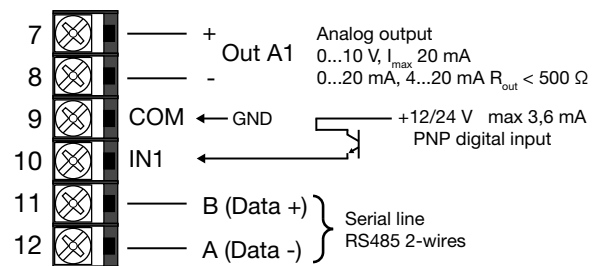

## 2.4. 4140 connection diagrams

### 2.4.1. General diagram

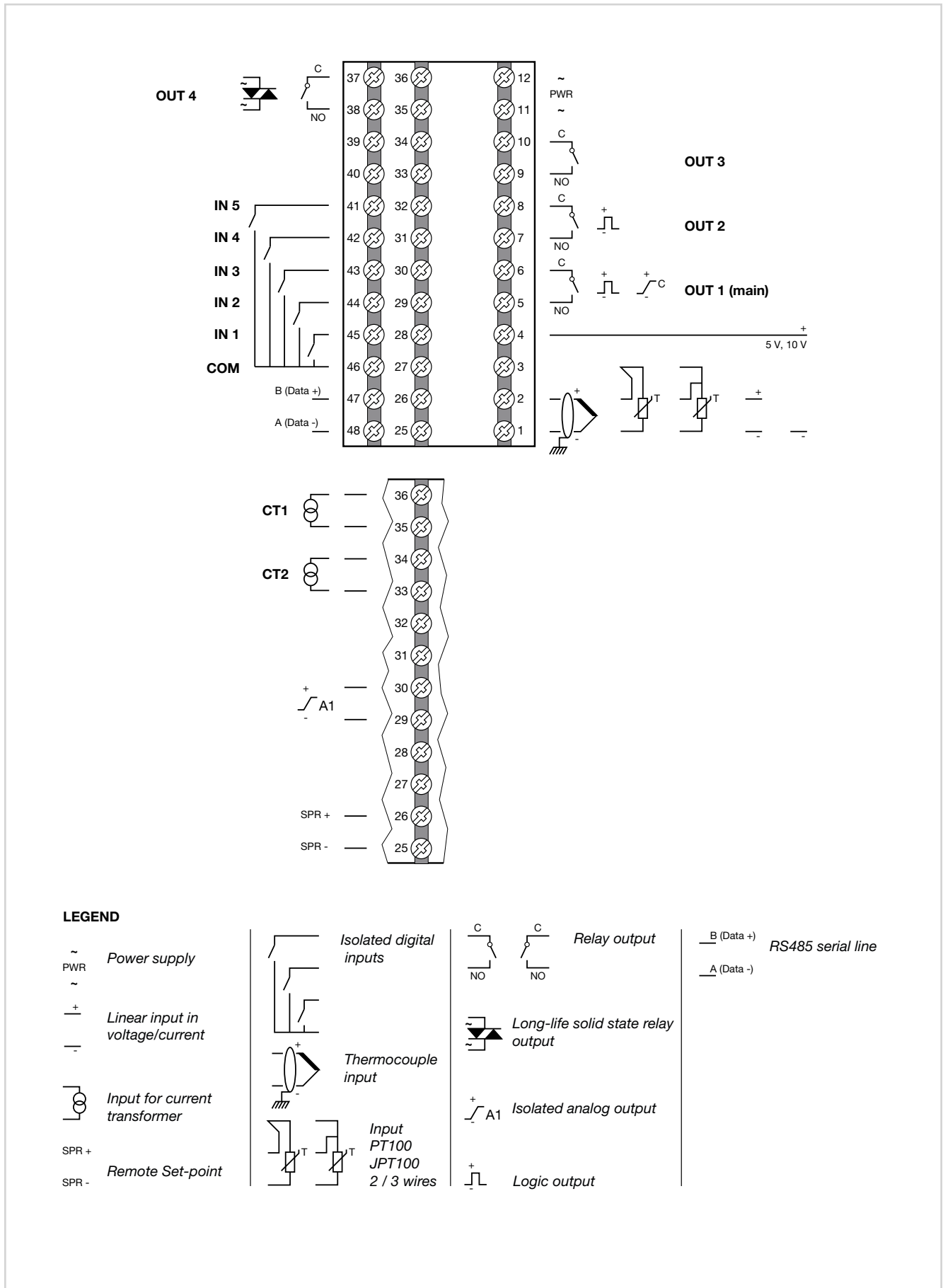

## 2. INSTALLATION

### 2.4.2. Power supply

#### Power supply

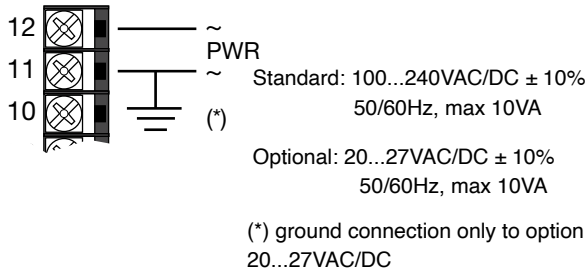

### 2.4.3. Inputs

#### TC inputs

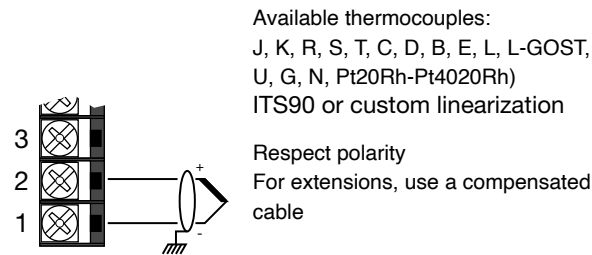

#### Linear input (V,I)

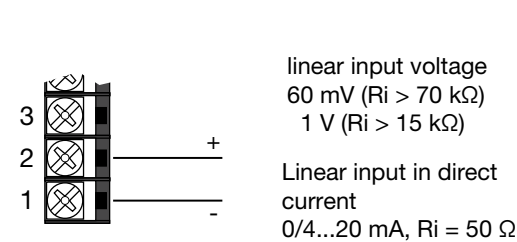

#### Linear input (V)

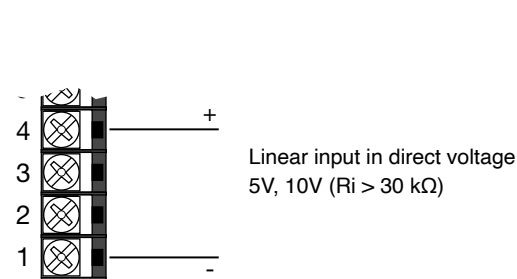

#### Input PT100/JPT100 - 2-wires connection

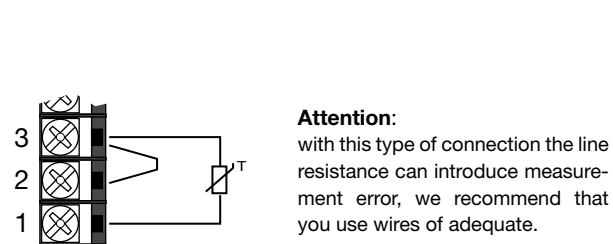

#### Input PT100/JPT100 - 3-wires connection

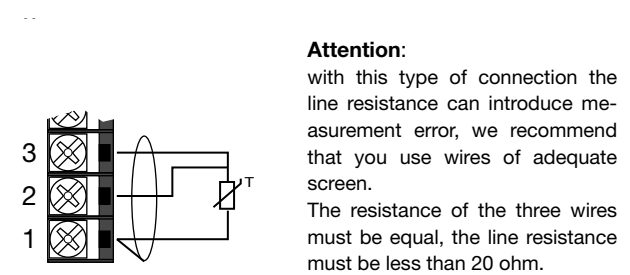

### 2.4.4. Outputs

Characteristics of outputs Out1, Out2, Out3, Out4 are defined when the controller is ordered.

#### Output Out 1 - 5 A relay

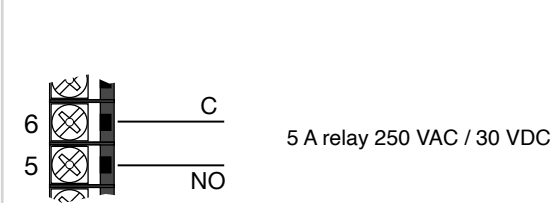

#### Output Out 1 - logic

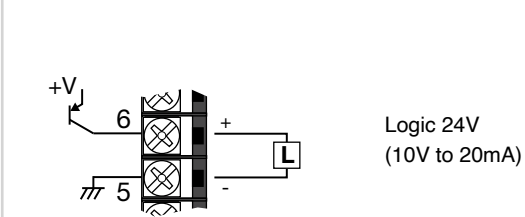

#### Output Out 1 - continuous

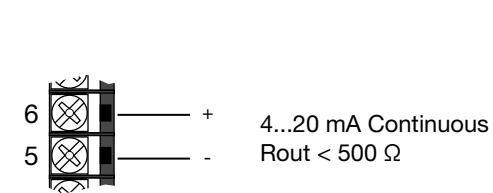

#### Output Out 2 - 5 A relay

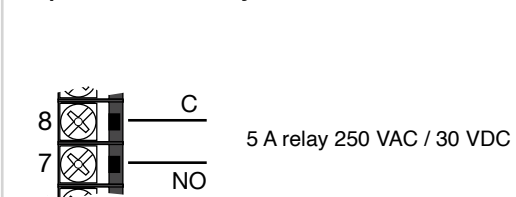

**Output Out 2 - logic**

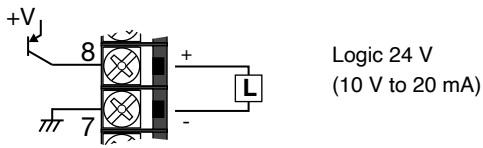

**Digital inputs**

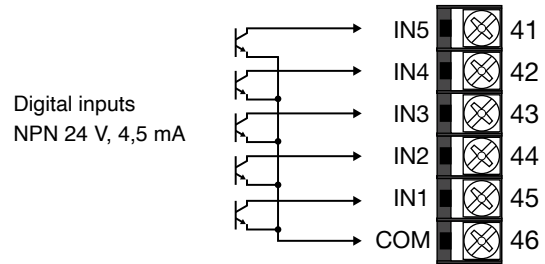

**Output Out 3 - 5 A relay**

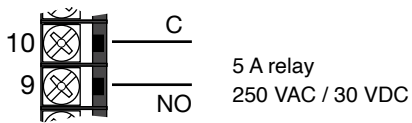

**Digital inputs**

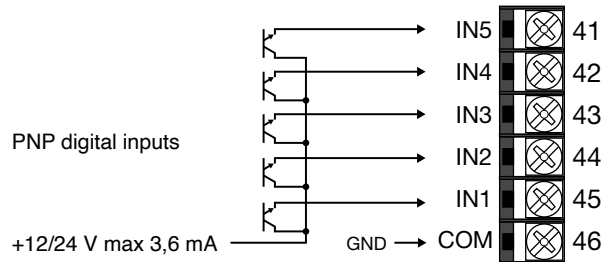

**Output Out 4 - 5 A relay**

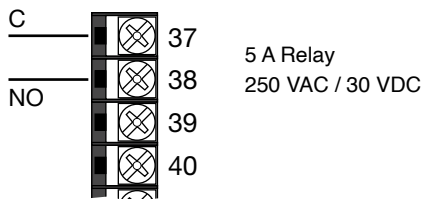

**2.4.6. Serial line**

**Serial line**



**Output Out 4 - Triac**

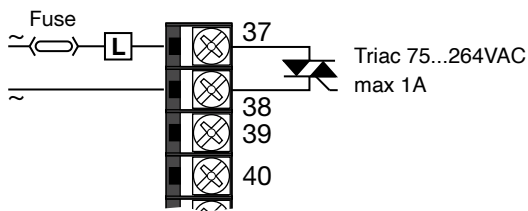

**2.4.7. CT Inputs**

**CT1, CT2 inputs**

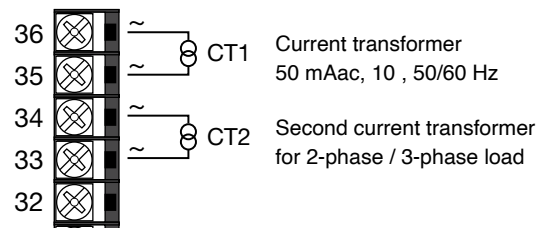

**2.4.5. Digital inputs**

**Digital inputs**

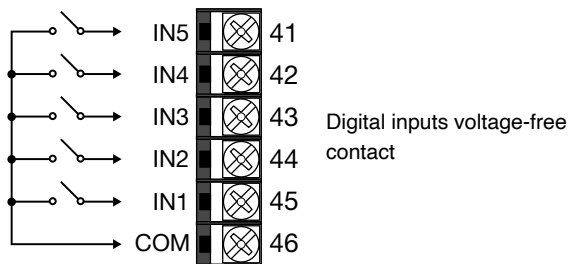

## 2. INSTALLATION

---

### 2.4.8. Remote setpoint input

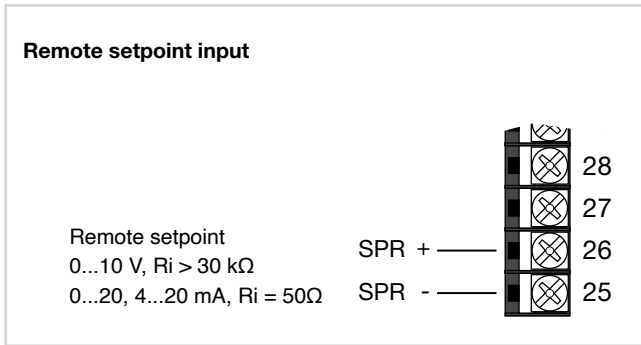

### 2.4.9. Analog output

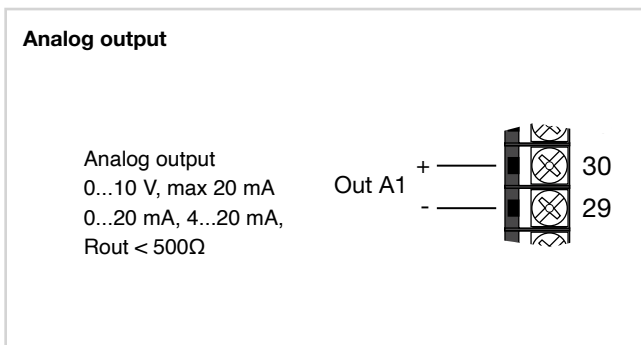

### 2.5. RS485 serial connection diagram

Up to 31 controllers (including different models) can be connected in parallel on the RS485 line. The line must end with a resistor (120 Ω, 1/2 W).

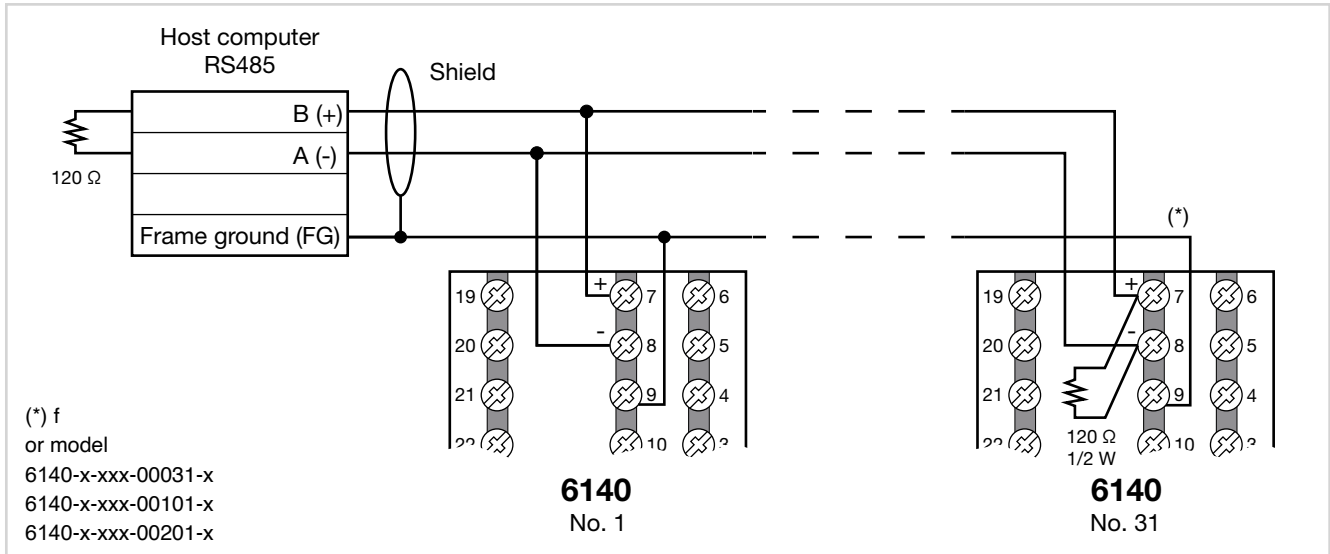

Figure 13 - RS485 connection for 6140 controller

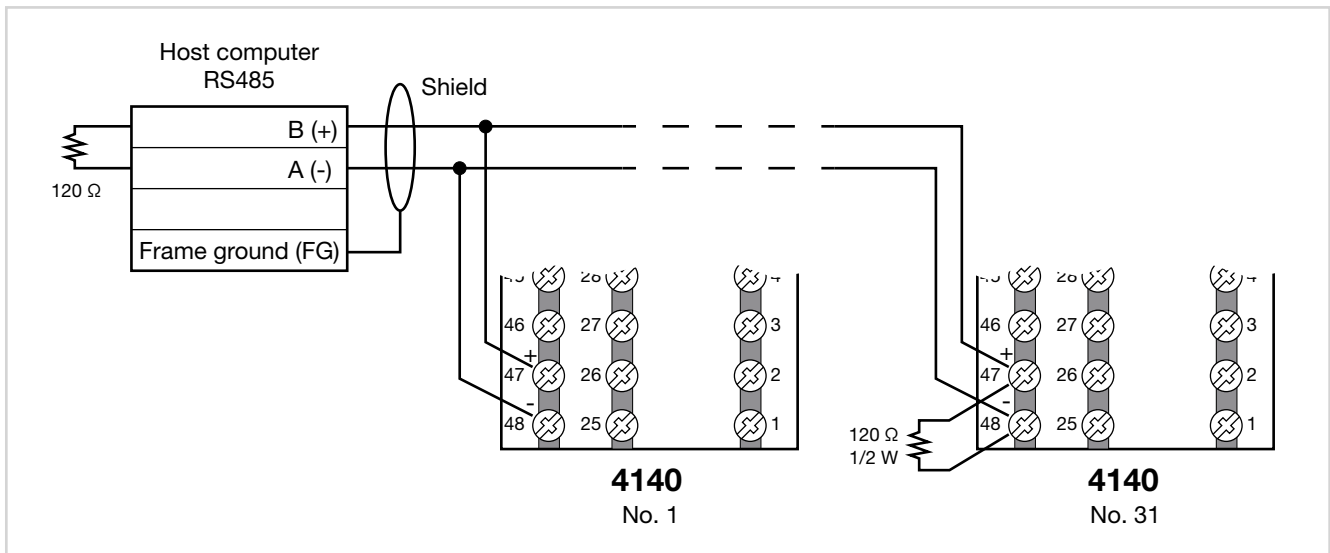

Figure 14 - RS485 connection for 4140 controllers



# 3. COMMISSIONING

## 3.1. Information on displays and use of keys

The general description of the displays and keys for each model is in paragraphs “1.3.1. Display and keys” on page 13 for the 6140, “1.4.1. “1.5.1. Display and keys” on page 17 for the 4140.

### 3.1.1. Navigating the menus

4 keys are used for navigating the menus and submenus and for changing parameters and confirming choices. Their function depends on the context and on how long they are pressed.

 The LEDs above the keys not only give confirmation that each key has been pressed (by flashing), but also show which keys can be used in each situation.

The navigation functions assigned to the keys are:

 At first power-on, scrolls the fast configuration menu; otherwise, the user configuration menu (Setpoint, Alarm limits, Control output, etc.). Each time you press the key, the value of the displayed parameter is confirmed and you go to the next menu item. Keep the key pressed for more than 2 seconds to enter the Programming/Configuration menu.

 Each time you press the key, you return to the previous menu item or to the higher menu level, as appropriate. Keep the key pressed for more than 2 seconds to return to the Main menu.

 Press the key to enter a submenu or to reduce the value of the displayed parameter, as appropriate. Keep the key pressed to progressively increase the speed of reduction of the displayed parameter

 Press the key to raise the value of the displayed parameter. Keep the key pressed to progressively increase the speed of raising the displayed parameter.

When the process variable is displayed, in standard configuration the key  switches the controller function mode (manual/automatic).

### 3.1.2. Displays

The controllers have 2 or 3 displays, depending on the model. The Main menu shows:

- PV display: value of process variable.
- SV display: value of parameter (default = setpoint, if parameter dS.SP = SETP).
- F Display (models 1250 and 1350 only): value of control output (if parameter dS.F = OUT.PW).

On model 4140, the percentage value of the control output is also shown graphically on a bargraph.

On model 4140, an additional display shows the program number, step number, and unit of measurement (% , A, kW, kWh).

According to the situation (programming, alarm, etc.), the controller displays can show other information, such as the name of the parameter, description of the parameter, diagnostics messages and alarm messages.

 **Attention!** The displays show only the parameters and menus for a defined configuration.

#### 3.1.2.1. Display characters

The displays reproduce the various characters by combining 7 or 14 segments.

The following tables show the shape of the various characters.

	!	"	#	\$	%	&	'	(	)
	∇	∥	≡	§	‰	∞	/	/	\
*	+	,	-	.	/	0	1	2	3
✱	†	/	..	..	/	0	1	2	3
4	5	6	7	8	9	:	:	<	=
4	5	6	7	8	9	-	-	/	:
>	?	@	A	B	C	D	E	F	G
\	?	@	A	B	C	D	E	F	G
H	I	J	K	L	M	N	O	P	Q
H	I	J	K	L	M	N	O	P	Q
R	S	T	U	V	W	X	Y	Z	[
R	S	T	U	V	W	X	Y	Z	[
\	]	^	_	`	a	b	c	d	e
\	]	^	_	`	a	b	c	d	e
f	g	h	i	j	k	l	m	n	o
f	g	h	i	j	k	l	m	n	o
p	q	r	s	t	u	v	w	x	y
p	q	r	s	t	u	v	w	x	y
z		~							
z		~							

Figure 15 - 14-segment font

### 3. COMMISSIONING

	!	“	#	\$	%	&	‘	(	)
*	+	,	-	.	/	0	1	2	3
4	5	6	7	8	9	:	;	<	=
>	?	@	A	B	C	D	E	F	G
H	I	J	K	L	M	N	O	P	Q
R	S	T	U	V	W	X	Y	Z	[

Figure 16 - 7-segment font

#### 3.1.2.2. Scrolling messages

The SV (6140) and F (4140) displays can show scrolling alphameric messages. These messages, up to 32 characters in length, appear:

- during configuration, describing the active parameter;
- during functioning, after the tripping of alarms, digital inputs and logic function outputs, if the relative messages were enabled

Message texts can be set via PC with C-PWR software.

There are 3 message groups, one for each of the 3 languages provided, selectable from the HMI menu with the LANG.n parameter. Each group contains up to 25 messages.

### 3.2. Sequence at power-on

The following diagram shows the controller sequence at power-on.

**Note:** the USB-TTL programming cable must be disconnected.

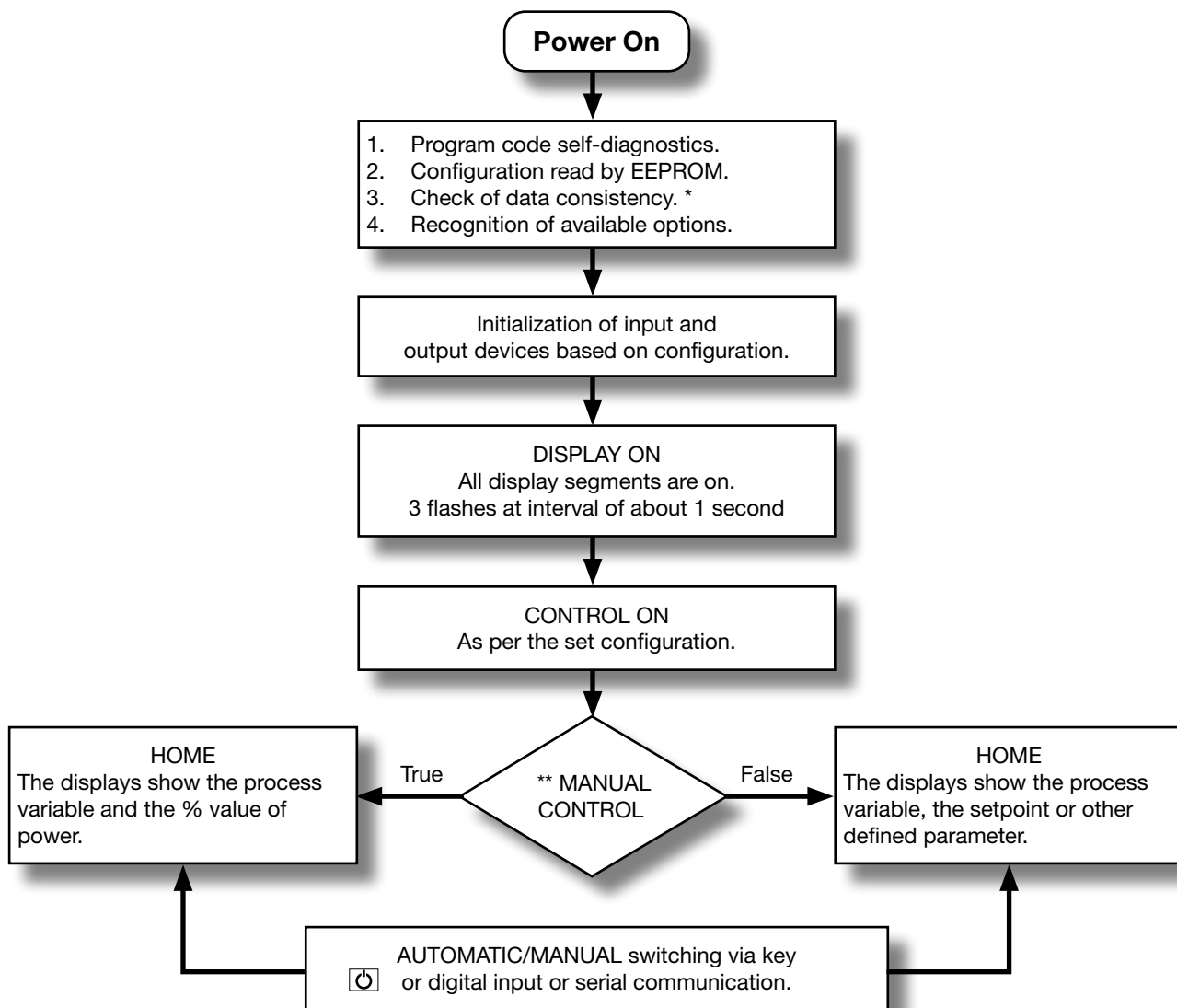

\*) Any error is signaled by the message EEPROM CHECKSUM ERROR.

\*\*) Only if MANUAL mode was used before the controller was powered off.

### 3.3. First power-on

At first power-on, after the controller has run the self-diagnostics test, press the **F** key to access the Fast Configuration Menu. The parameters shown are a subset of all the controller parameters and let you rapidly configure the inputs and outputs.

The number and type of the parameters shown depends on the controller HW configuration and on the choices made with the parameters previously shown.

For example, minimum and maximum scale limits are shown only if you have chosen an mA or V type temperature sensor.

Fast Configuration also appears if the HMI menu is set to parameter QuiCk = On

#### 3.3.1. Fast configuration

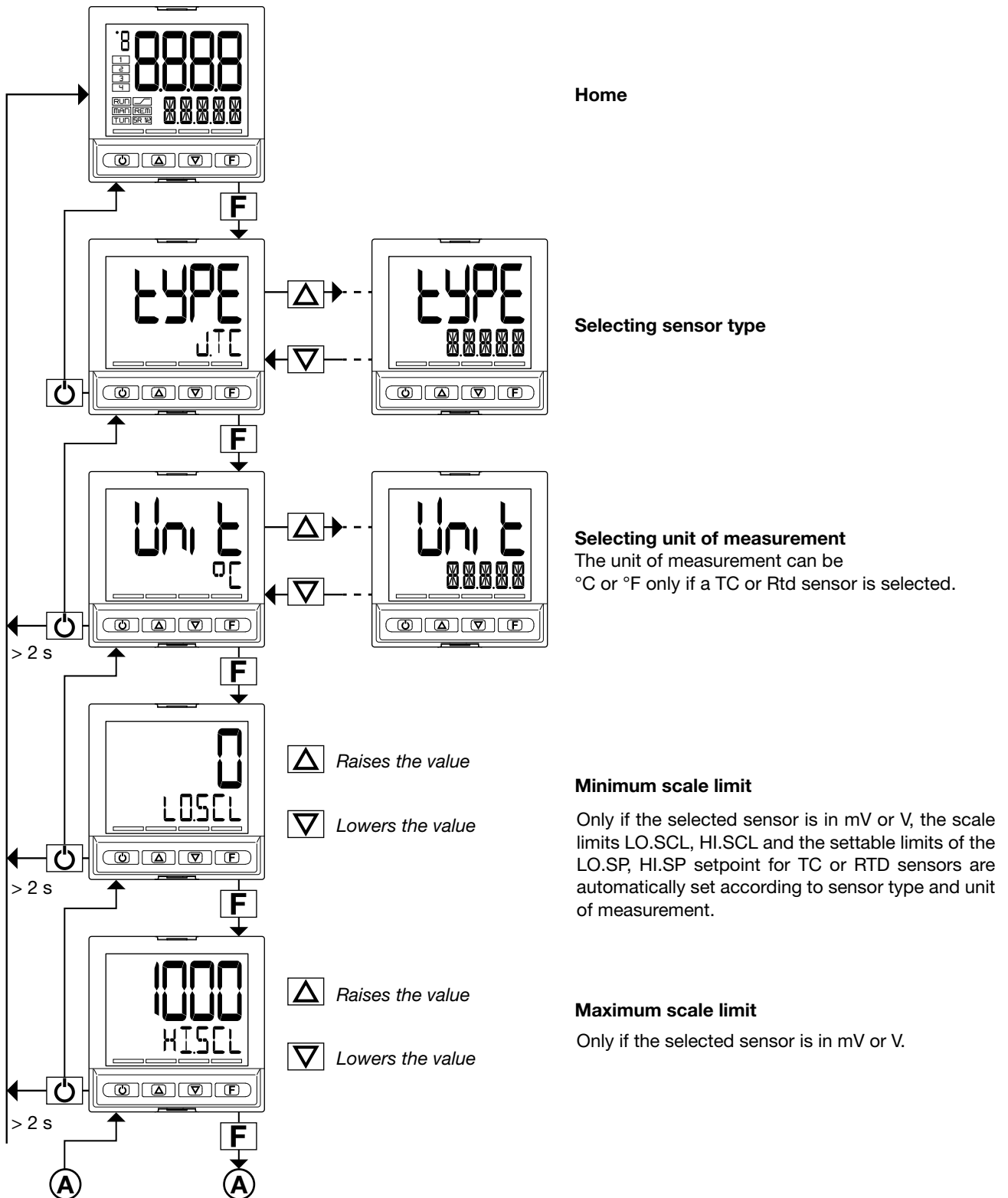

### 3. COMMISSIONING

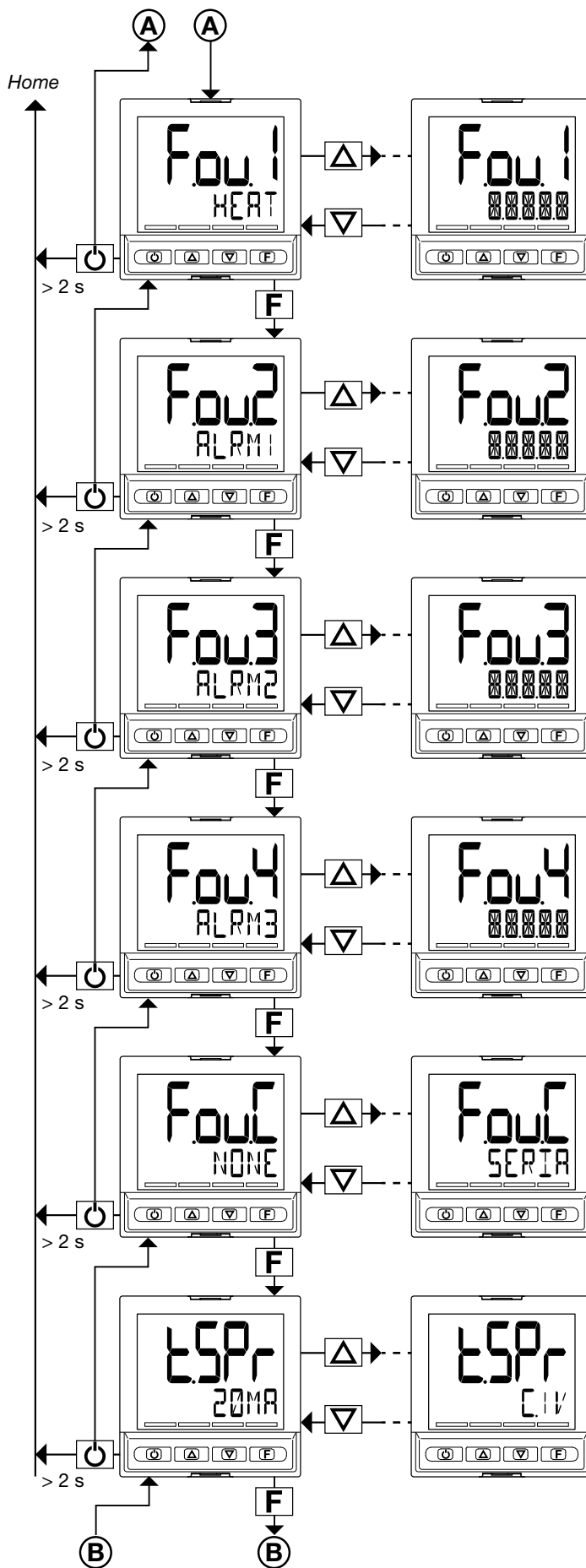

#### Selecting output 1 function

The proposed functions depend on output type (relay, logic).

#### Selecting output 2 function

The proposed functions depend on output type (relay, logic).

#### Selecting output 3 function

The menu item appears only if the optional output is available.

#### Selecting output 4 function

The menu item appears only if the optional output is available

#### Selecting analog output function

The menu item appears only if the output continuous Out1 4-20mA.

#### Selecting remote setpoint type

The menu item appears only if the optional input is available.

The setpoint scale depends on the sensor selected.

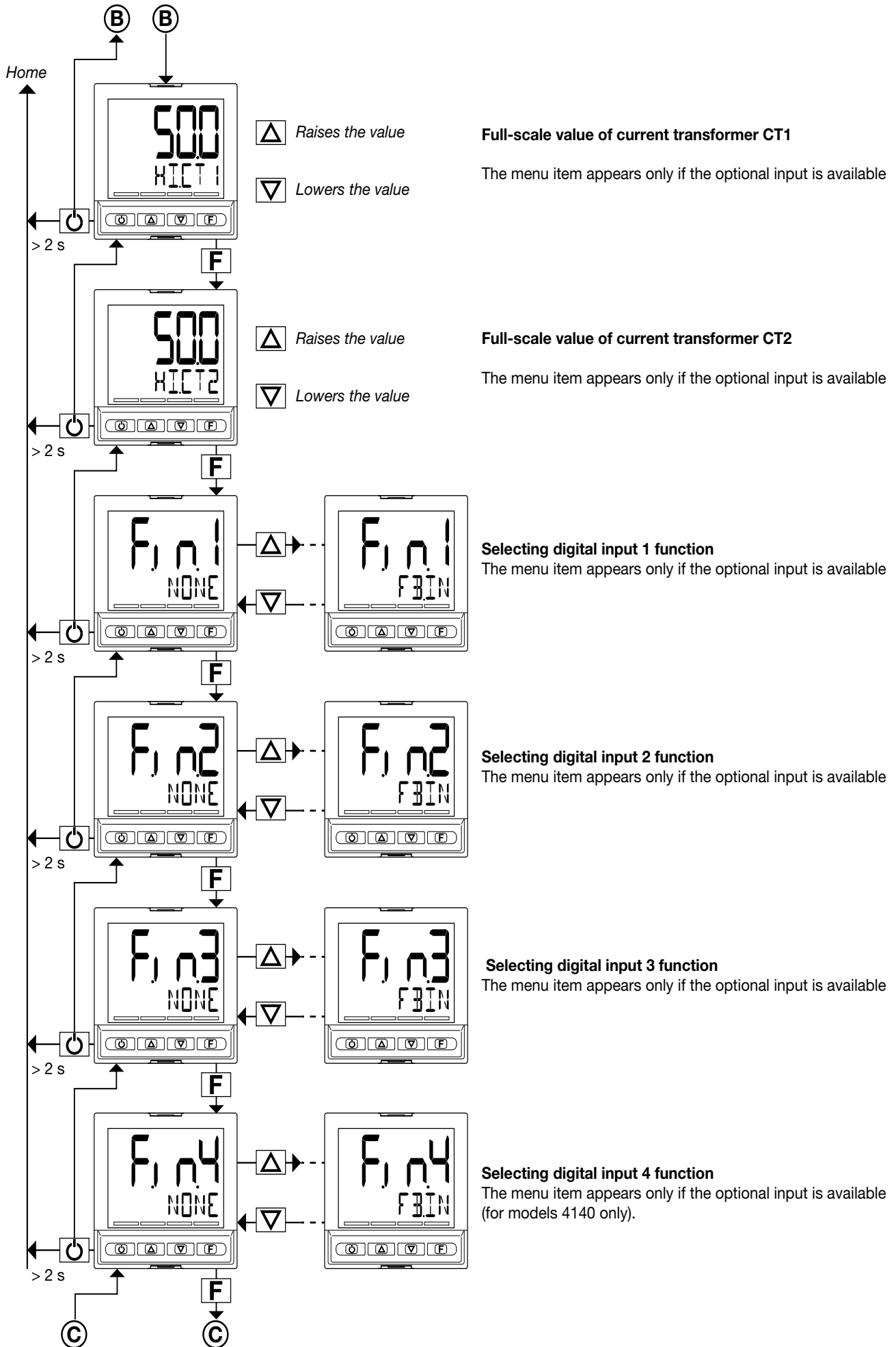

### 3. COMMISSIONING

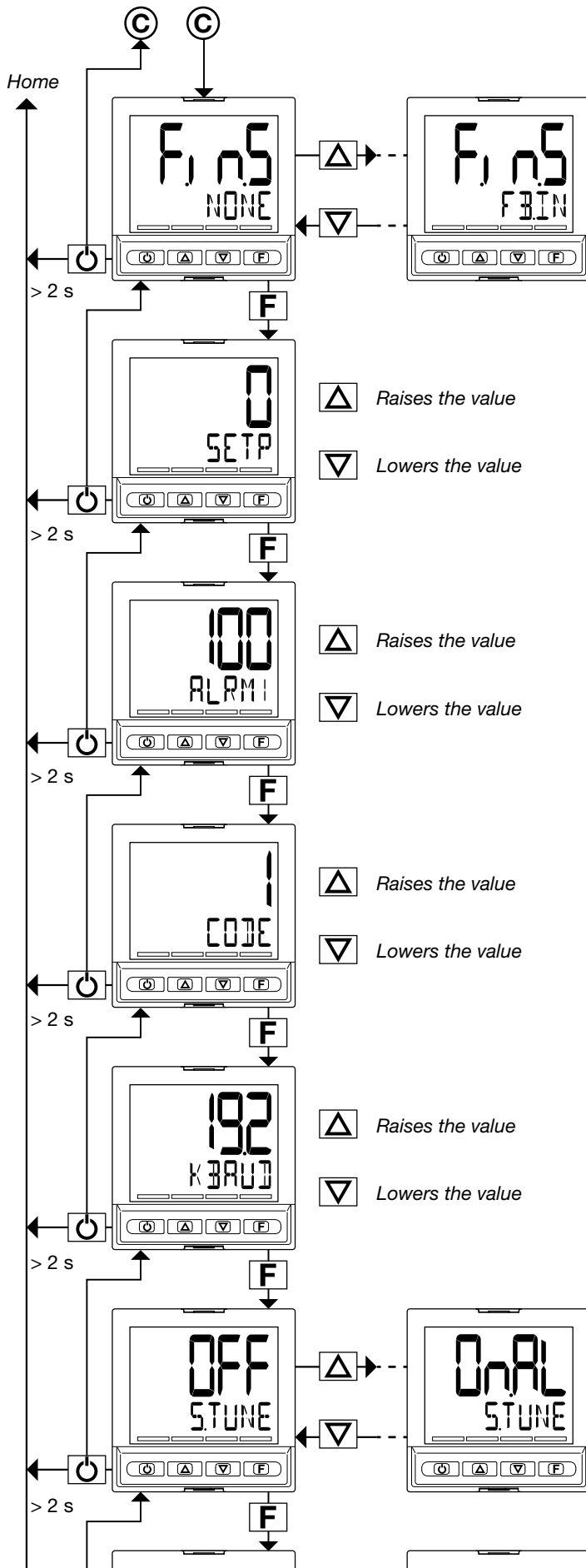

#### Selecting digital input 5 function

The menu item appears only if the optional input is available (for models 4140 only).

#### Setting Setpoint

- Raises the value
- Lowers the value

#### Setting Alarm 1

- Raises the value
- Lowers the value

#### Setting Modbus address

The menu item appears only if the optional RS485 port is available.

- Raises the value
- Lowers the value

#### Selecting baudrate

The menu item appears only if the optional RS485 port is available.

- Raises the value
- Lowers the value

#### Turning on Self-Tuning

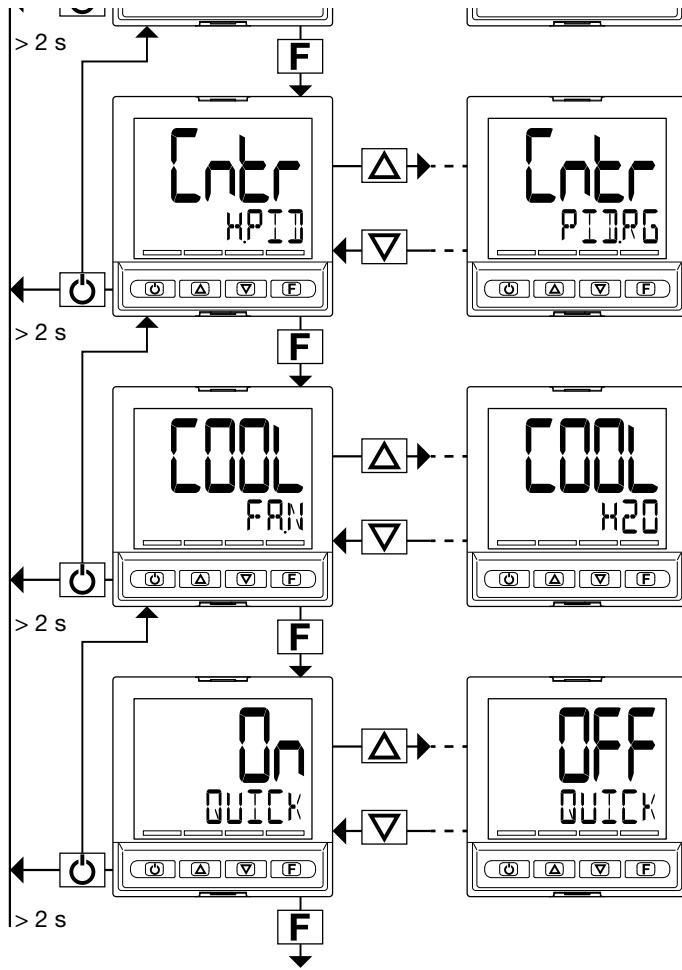

**Selecting the type of control**

The menu item appears only if one of the outputs is set to COOL.

**Selecting the cooling fluid**

The menu item appears only if one of the outputs is set to COOL and the control type PID.RG (PID heating / cooling action with relative gain)

**Enabling / disabling Fast Configuration**

Selection of probe type

### 3. COMMISSIONING

#### 3.4. Setting up quick configuration

The quick configuration menu lets you quickly configure and start a controller.

To do this, it uses default values for many of the parameters assigned to the functions and other parameters are not activated.

With this configuration, the controller can satisfy the majority of operating requirements.

You can set up the first configuration with the main configuration menu (see paragraph “4.1 Programming/Configuration Menu” on page 43), which gives access to all of the parameters.

For purposes of example, some of the controller’s main functions are listed below, with a list of parameters to be changed after running fast configuration to adapt the controller to specific working conditions.

##### 3.4.1. Setting up the Alarm

If at least one output was configured as Alarm in the fast configuration.

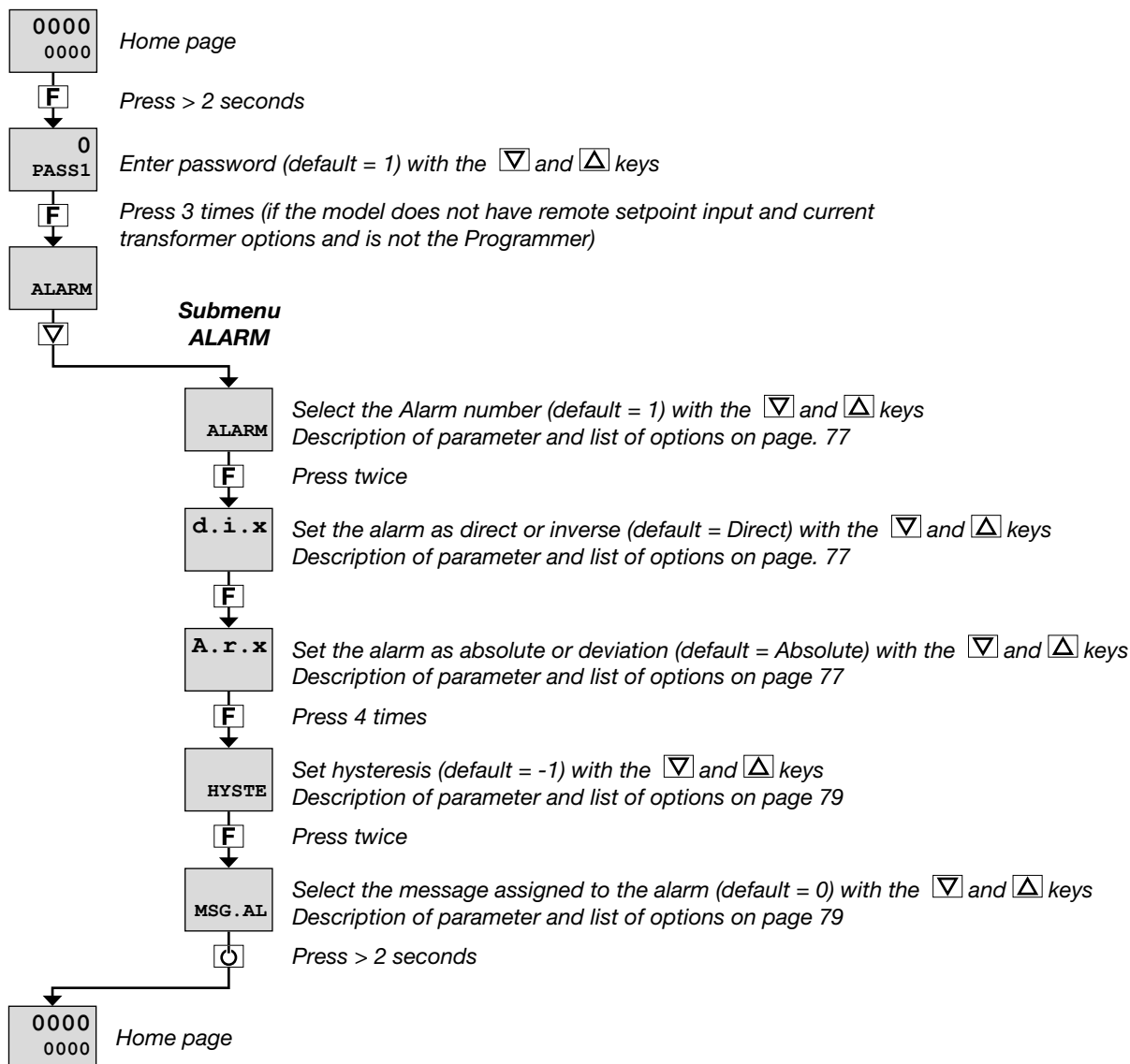

The ALARM submenu also lets you:

- select the input or value to be monitored for the alarm (parameter rEF.x, default = PV);
- select the method for applying hysteresis (parameter n.S.x, default = NORML);
- enable or disable the power-on alarm (parameter PWON.E, default = OFF);
- latch/not latch the active alarm state (parameter LA-TCH, default = OFF);
- set the alarm trip delay (parameter DELAY, default = 0.00);
- activate or deactivate flashing of the PV display in case of alarm (parameter BLK.AL, default = OFF).

### 3.4.2. Setting up the Heater Break Alarm

If at least one output was configured as Heater Break Alarm in the fast configuration.

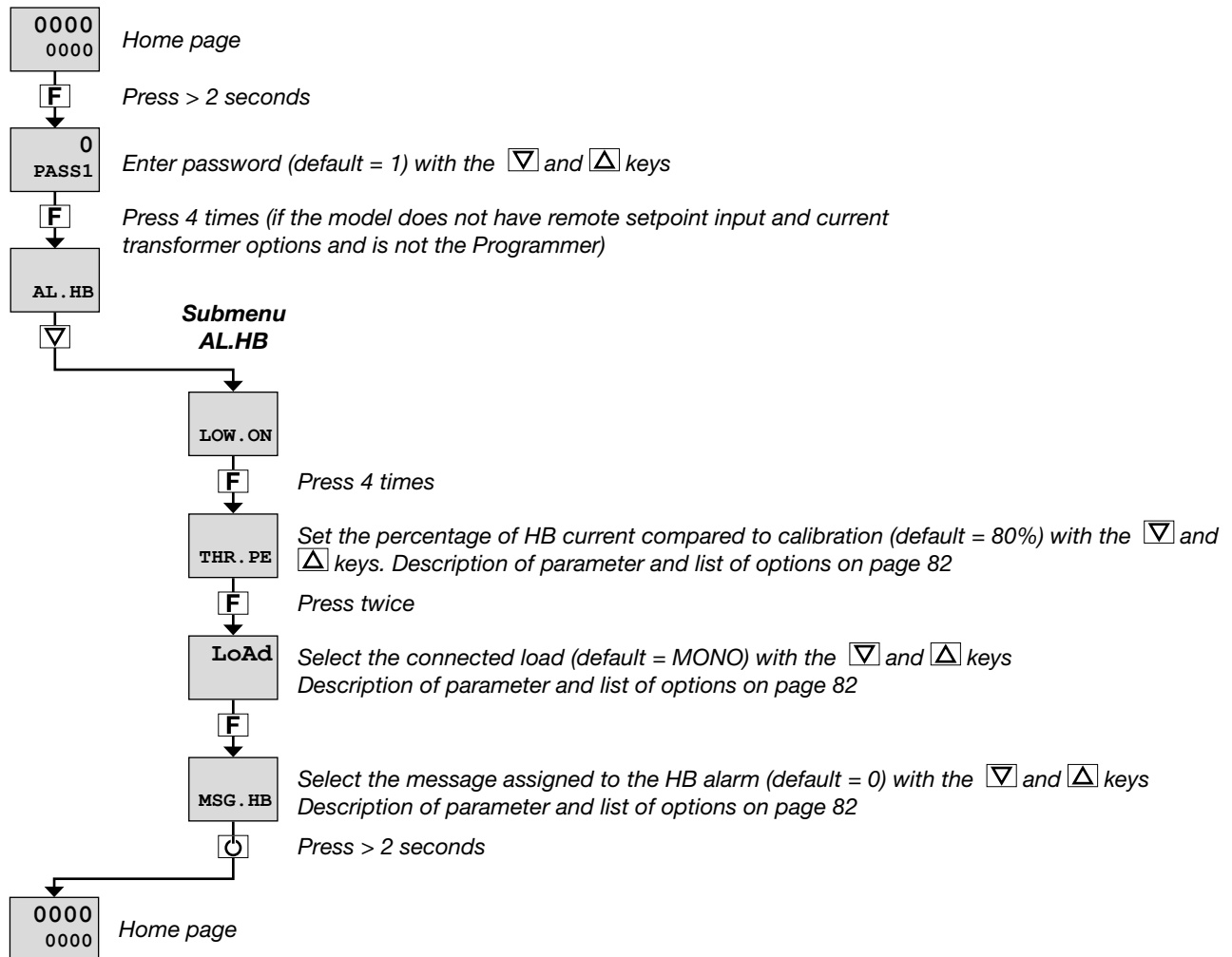

The AL.HB submenu also lets you:

- set an HB alarm due to low current draw (parameter LOW.ON, default = 0.0);
- set an HB alarm due to high current draw (parameter HIG.ON, default = 0.0);
- set an HB alarm due to excess current draw (parameter HI.OFF, default = 0.0);
- set the HB alarm trip delay (parameter TIME, default = 0);
- select the control output assigned to the HB alarm (parameter OUT, default = 1);
- activate or deactivate flashing of the PV display in case of alarm (parameter BLK.AL, default = OFF).

### 3. COMMISSIONING

#### 3.4.3. Setting up the PID

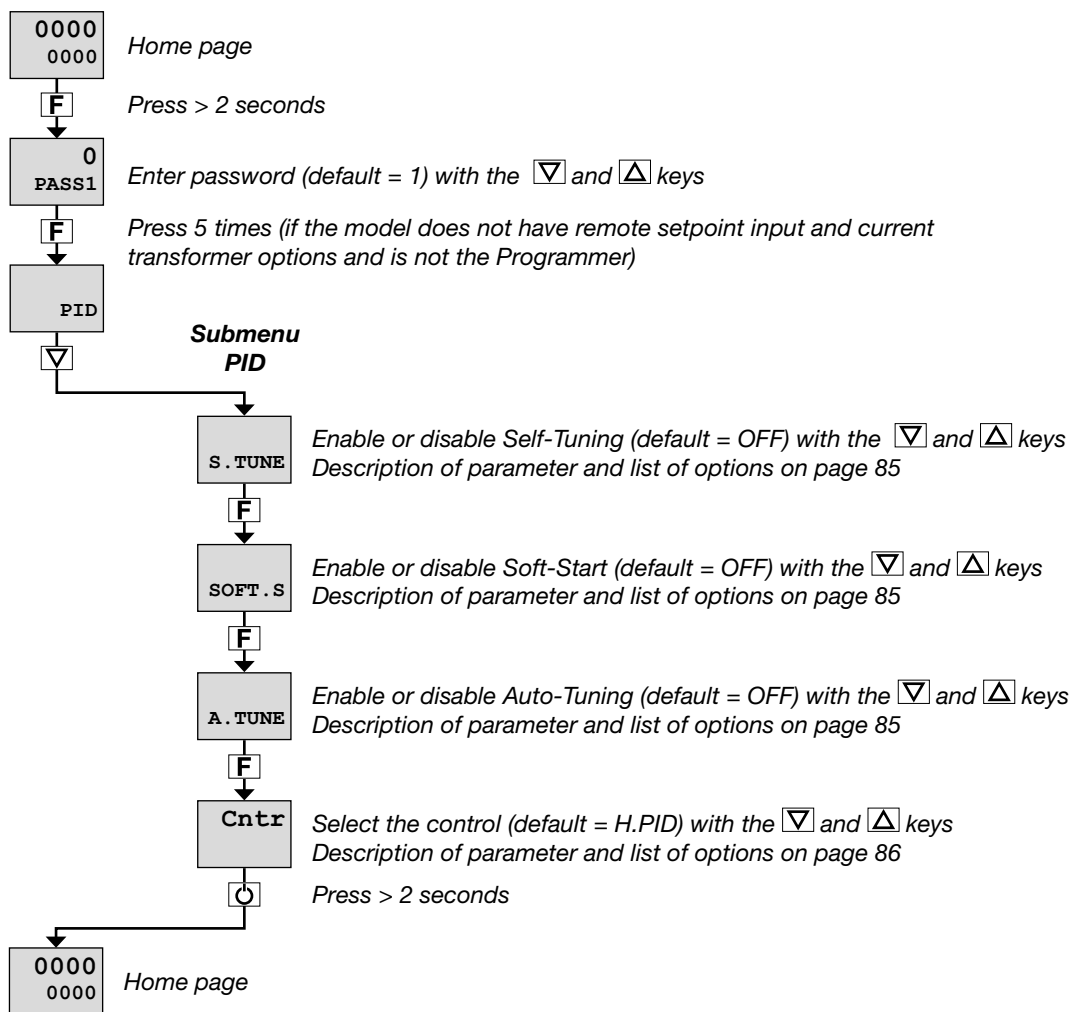

The PID submenu also lets you:

- set the Soft-Start time (parameter SOFT.T, default = 0.0);
- select the type of Auto-Tuning used (parameter Aut.t, default = CONT);
- set the derivative time (parameter DERV.S, default = 1);
- set the proportional heating band or hysteresis in ON-OFF control (parameter H.PB, default = 1.0);
- set the integral heating time (parameter H.IT, default = 4.00);
- set the derivative heating time (parameter H.DT, default = 1.00);
- set the maximum heating power limit (parameter H.PHI, default = 100.0);
- set the minimum heating power limit (parameter H.PLO, default = 0.0);
- select the cooling fluid (parameter COOL, default = FAM);
- set the cooling setpoint compared to the heating setpoint (parameter C.SP, default = 0.0);
- set the proportional cooling band or hysteresis in ON-OFF control (parameter C.PB, default = 1.0);
- set the integral cooling time (parameter C.IT = 4.00);
- set the derivative cooling time (parameter C.DT = 1.00);
- set the maximum cooling power limit (parameter C.PHI, default = 100.0);
- set the minimum cooling power limit (parameter C.PLO, default = 0.0);
- set the Manual Reset value (parameter RESET, default = 0);
- set the Reset Power value (parameter P.RST, default = 0.0);
- set the Antireset value (parameter A.RST, default = 0);
- set the Feedforward Power value (parameter, default = 0.0);
- set the deadband (parameter DEAD.B, default = 0);
- set the fault action power (parameter FAULT, default = 0.0);
- set the setpoint gradient in raise (parameter GRAD.I, default = 0.0);
- set the setpoint gradient in lower (parameter GRAD.D, default = 0.0);
- select the gradient unit of measurement (parameter Unit, default = DIG/S);
- set the control output gradient (parameter GRAD.O, default = 0.0);

- set the LBA alarm trip delay LBA (parameter LBA.TM, default = 30.0);
- set the value of power delivered when the LBA alarm trips (parameter LBA.PW, default = 25.0).



## 4. CONFIGURATION

The fast configuration described in the previous chapter lets you rapidly put the controller into operation.

To do this, the procedure configures the controller's main parameters only, which satisfies the most common application requirements.

On the other hand, to satisfy all application requirements and to configure the controller in detail, you have to set the parameters that are accessible only on the Programming/Configuration menu.

This type of configuration is also useful for common applications (the ones covered by fast configuration), because optimum controller function depends a great deal on correct configuration and programming of the control parameters provided.

The controller can be configured with the buttons on its panel and from the PC with C-PWR software (see chapter "7. Programming with PC" on page 159).

### 4.1. Programming/Configuration Menu

#### 4.1.1. First: know what you're doing

Correctly setting the parameters needed to configure the controller requires thorough knowledge of the problems and techniques involved.

If you are unsure of your know-how, or are not fully aware of the consequences of incorrectly setting the parameters, we advise you not to configure the controller with this menu.



**Attention!** To prevent harm to persons and damage to property, the user must check that the parameters are correctly set before commissioning the controller.

In case of doubts, or if you need any explanations, please consult [www.chromalox.com](http://www.chromalox.com) or contact Chromalox Customer Care.

#### 4.1.2. Passwords

The configuration menu is protected by 2 passwords that allow access to two different menu sections.

The first section, accessed with password 1, groups the most operative submenus and parameters, i.e., the ones most involved in daily functioning of the controlled machine or system.

The second section, accessed with password 2, groups the submenus and parameters used to configure HW resources

The factory password settings are:

- Password 1 = 1
- Password 2 = 2

The passwords can be changed and even disabled if you want. See paragraphs "4.27. PASC1 - Setting level 1 password 1" on page 144 and "4.28. PASC2 - Setting level 2 password 2" on page 144

#### 4.1.3. Password in the User Menu

Two passwords can be entered in the User menu, respectively:

- Password 0 (default = 10 see paragraph "4.26. PASC0 - Setting level 0 password 0" on page 144 )
- Password 1 to inhibit navigation to parameters in positions subsequent to that assigned to the password.

Once one of the two passwords is reached:

- if the value entered matches the value expected, navigation continues in the User Menu
- if the value entered does not match the value expected, the Home screen will be displayed

## 4. CONFIGURATION

### 4.2. Main menu

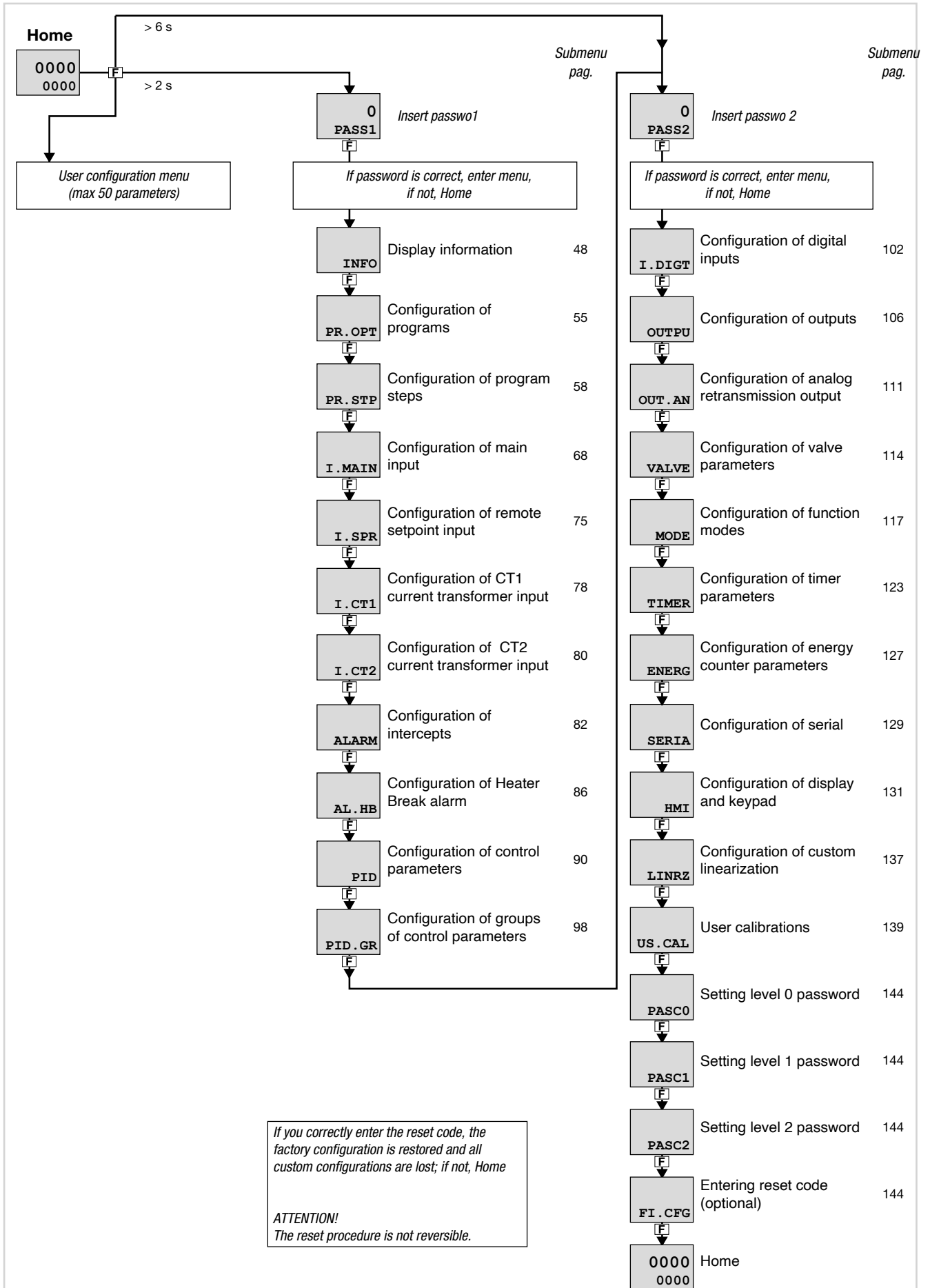

### 4.3. Legend for submenus and parameters

The purposes and characteristics of submenus and parameters are described and summarized in the following tables.

#### 4.3.1. Submenu

Acronym	Scrolling message	Password	Description
INFO	INSTRUMENT STATUS	Level 1	Gives information on controller state and HW configuration

1. Acronym of submenu as it appears on controller display.
2. Text of scrolling message as it appears on controller display.
3. Password needed to access submenu items.
4. Description of functions that manage submenu

#### 4.3.2. Parameters

Acronym	Scrolling message	Submenu	Attributes
Out1	OUTPUT TYPE	INFO	R

● The parameter specifies the type of output 1  
 ● **Unit of measurement:** -  
 ● **Options:**  
     **RELAY** = Relay output  
     **DIGIT** = 24 V logic output  
     **CONTS** = Continuous output

1. Acronym of parameter as it appears on controller display.
2. Text of scrolling message as it appears on controller display.
3. Submenu to which parameter belongs.
4. Attributes of parameter: R = readable, W = writable. If only R, the operator or technician can read the parameter value but cannot change it.
5. Description of use of parameter, including any warnings or suggestions.
6. Unit of measurement of value managed by parameter. The unit of measurement can be unique or depend on other configuration choices, for example, the unit of measurement of temperature, which can be set in degrees Centigrade or Fahrenheit. Not all parameters require the use of units of measurement.
7. Description of parameter values or information that can be read or written, as appropriate.
8. Value that the parameter can have. Value can be two types: discrete or pertaining to an interval of values, typically numerical. For a discrete value, all possible values are listed as they appear on the controller display. For intervals of values, the minimum and maximum parameter values are shown.
9. Any additional description of value of individual parameter.

## 4. CONFIGURATION

### 4.4. INFO Submenu - information display

Acronym	Scrolling message	Password	Description
INFO	INSTRUMENT STATUS	Level 1	Gives information on controller state and HW configuration.

Parameter	Pag.	Parameter	Pag.	Parameter	Pag.
<b>SW.VER</b> Software version	49	<b>CT1</b> Current transformer input available *	51	<b>OUT4.S</b> Number of switchings output 4 ***	53
<b>CODE</b> Identifying code of controller	49	<b>1.IN.DG</b> Digital input available *	51	<b>T.DAYS</b> Total working days	53
<b>ERROR</b> Main input error	49	<b>RS485</b> RS485 serial port available *	51	<b>P.DAYS</b> Partial working days	53
<b>SAP.C</b> SAP code	49	<b>Out1</b> Type of output 1 *	51	<b>T.INT</b> Internal temperature of controller	53
<b>SEr.n</b> Serial number of controller	49	<b>Out2</b> Type of output 2 *	51	<b>T.MIN</b> Internal temperature of controller	53
<b>614.LV</b> Model of controller	50	<b>Out3</b> Type of output 3 *	52	<b>T.MAX</b> Maximum internal temperature of the controller	54
<b>CONTR</b> Type of controller	50	<b>Out4</b> Type of output 4 *	52	<b>time</b> Internal time	54
<b>L.FUNC</b> Option Logic Functions available	50	<b>OUT1.S</b> Number of switchings output 1 **	52	<b>dAtE</b> Internal date	54
<b>IN.SPR</b> Remote setpoint input available *	50	<b>OUT2.S</b> Number of switchings output 2 ***	52		
<b>OUT.A1</b> Analog output 1 available *	50	<b>OUT3.S</b> Number of switchings output 3 ***	52		

\* Only appears if the function is available

\*\* Only appears if Output 1 is the relay or logic type

\*\*\* It only appears if the corresponding output is available and is of relay or logic type.

## 4.4.1. SW.VER - Versione software

Acronym	Scrolling message	Password	Description
SW.VER	SOFTWARE VERSION	INFO	R
<p>The parameter shows the version (<i>major.minor</i>) of the controller software.</p> <p><b>Unit of measurement:</b> -</p> <p><b>Options:</b> -</p>			

## 4.4.2. CODE - Identifying code of controller

Acronym	Scrolling message	Password	Description
CODE	INSTRUMENT ID CODE FOR SERIAL COMM	INFO	R
<p>The parameter shows identifying code of the device for serial communication.</p> <p><b>Unit of measurement:</b> -</p> <p><b>Options:</b> 0...247</p>			

## 4.4.3. ERROR - Main input error

Acronym	Scrolling message	Password	Description
ERROR	MAIN INPUT ERROR	INFO	R
<p>The parameter shows error detected by the main input.</p> <p><b>Unit of measurement:</b> -</p> <p><b>Options:</b></p> <ul style="list-style-type: none"> <li><b>nonE</b> = No error</li> <li><b>Lou</b> = Process variable (PV) is below lower scale limit</li> <li><b>HIGH</b> = Process variable (PV) is higher than upper scale limit</li> <li><b>Err</b> = PT100 in short circuit or input values below lower limit (for example, TC with incorrect connection)</li> <li><b>Sbr</b> = Sensor break or input values higher than upper limit</li> </ul>			

## 4.4.4. SAP.C - SAP code

Acronym	Scrolling message	Password	Description
SAP.C	SAP ORDER CODE	INFO	R
<p>The parameter shows the product number (Fxxxxxx).</p> <p><b>Unit of measurement:</b> -</p> <p><b>Options:</b> -</p>			

## 4.4.5. SEr.n - Serial number of controller

Acronym	Scrolling message	Password	Description
SEr.n	SERIAL NUMBER	INFO	R
<p>The parameter shows the serial number of the controller (number shown on data plate). The serial number is displayed in the form <i>yy.ww nnnn</i>, where</p> <ul style="list-style-type: none"> <li><i>yy</i> = last two digits of year of production</li> <li><i>ww</i> = week of production</li> <li><i>nnnn</i> = progressive in week of production</li> </ul> <p><b>Unit of measurement:</b> -</p> <p><b>Options:</b> -</p>			

## 4. CONFIGURATION

### 4.4.6. xxxxx - Model of controller

Acronym	Scrolling message	Submenu	Attributes
xxxxx	MODEL	INFO	R
<p>The parameter shows the model of the controller. xxxxx indicates the controller model.</p> <p><b>Unit of measurement:</b> -</p> <p><b>Options:</b></p> <ul style="list-style-type: none"> <li><b>614.LV</b> = 6140 controller powered at 20...27 VAC/VDC</li> <li><b>614.HV</b> = 6140 controller powered at 100...240 VAC/VDC</li> <li><b>414.LV</b> = 4140 controller powered at 20...27 VAC/VDC</li> <li><b>414.HV</b> = 4140 controller powered at 100...240 VAC/VDC</li> </ul>			

### 4.4.7. xxxxx - Type of controller

Acronym	Scrolling message	Submenu	Attributes
xxxxx	MODEL OPTION	INFO	R
<p>The parameter shows the type (xxxxx) of function of the controller.</p> <p><b>Unit of measurement:</b> -</p> <p><b>Options:</b></p> <ul style="list-style-type: none"> <li><b>CONTR</b> = The device functions only as a controller</li> <li><b>PROGR</b> = The device functions as a programmer and controller</li> <li><b>VALVE</b> = The device functions as a controller with valve control</li> <li><b>PR+VA</b> = The device functions as a programmer and controller with valve control</li> </ul>			

### 4.4.8. L.FUNC - Option Logic Functions available

Acronym	Scrolling message	Submenu	Attributes
L.FUNC	LOGIC FUNCTION AVAILABLE	INFO	R
<p>If present, this parameter indicates that the controller option is installed Logic Functions.</p> <p><b>Unit of measurement:</b> -</p> <p><b>Options:</b> -</p>			

### 4.4.9. IN.SPR - Remote setpoint input available

Acronym	Scrolling message	Submenu	Attributes
IN.SPR	REMOTE SETPOINT AVAILABLE	INFO	R
<p>If present, the parameter indicates that the remote setpoint input is installed on the controller.</p> <p><b>Unit of measurement:</b> -</p> <p><b>Options:</b> -</p>			

### 4.4.10. OUT.A1 - Analog output 1 available

Acronym	Scrolling message	Submenu	Attributes
OUT.A1	ANALOG OUTPUT AVAILABLE	INFO	R
<p>If present, the parameter indicates that the analog output in voltage or current is installed on the controller.</p> <p><b>Unit of measurement:</b> -</p> <p><b>Options:</b> -</p>			

## 4.4.11. CTx - Current transformer input available

Acronym	Scrolling message	Submenu	Attributes
CTx	CURRENT TRASFORMER AVAILABLE	INFO	R
<p>If present, the parameter indicates that one or more current transformer inputs are installed on the controller.</p> <p><b>Unit of measurement:</b> -</p> <p><b>Options:</b>           <b>CT1</b>    = The device has 1 current transformer input                            <b>CT1+2</b> = The device has 2 current transformer inputs</p>			

## 4.4.12. x.IN.DG - Digital input available

Acronym	Scrolling message	Submenu	Attributes
x.IN.DG	DIGITAL INPUT AVAILABLE	INFO	R
<p>If present, the parameter indicates how many digital inputs are installed on the controller.</p> <p><b>Unit of measurement:</b> -</p> <p><b>Options:</b>           <b>1.IN.DG</b> = 1 digital input installed on the controller                            <b>2.IN.DG</b> = 2 digital input installed on the controller                            <b>3.IN.DG</b> = 3 digital input installed on the controller                            <b>5.IN.DG</b> = 4 digital input installed on the controller</p>			

## 4.4.13. RS485 - RS485 serial port available

Acronym	Scrolling message	Submenu	Attributes
RS485	FIELDBUS AVAILABLE	INFO	R
<p>If present, the parameter indicates that an RS485 is installed on the controller.</p> <p><b>Unit of measurement:</b> -</p> <p><b>Options:</b>           -</p>			

## 4.4.14. Out1 - Type of output 1

Acronym	Scrolling message	Submenu	Attributes
Out1	OUTPUT TYPE	INFO	R
<p>The parameter specifies the type of output 1.</p> <p><b>Unit of measurement:</b> -</p> <p><b>Options:</b>           <b>RELAY</b> = Relay output                            <b>DIGIT</b> = 24 V logic output                            <b>CONTS</b> = Continuous current output</p>			

## 4.4.15. Out2 - Type of output 2

Acronym	Scrolling message	Submenu	Attributes
Out2	OUTPUT TYPE	INFO	R
<p>present, the parameter indicates that output 2 is available on the controller and specifies the type.</p> <p><b>Unit of measurement:</b> -</p> <p><b>Options:</b>           <b>RELAY</b> = Relay output                            <b>DIGIT</b> = 24 V logic output</p>			

## 4. CONFIGURATION

### 4.4.16. Out3 - Type of output 3

Acronym	Scrolling message	Submenu	Attributes
Out3	OUTPUT TYPE	INFO	R
If present, the parameter indicates that output 3 is available on the controller and specifies the type. <b>Unit of measurement:</b> - <b>Options:</b> <b>RELAY</b> = Relay output <b>TRIAC</b> = Triac output (only for 650 model)			

### 4.4.17. Out4 - Type of output 4

Acronym	Scrolling message	Submenu	Attributes
Out4	OUTPUT TYPE	INFO	R
If present, the parameter indicates that output 4 is available on the controller and specifies the type. <b>Unit of measurement:</b> - <b>Options:</b> <b>RELAY</b> = Relay output <b>TRIAC</b> = Triac output (only for 1250 and 1350 models)			

### 4.4.18. OUT1.S - Number of switchings output 1

Acronym	Scrolling message	Submenu	Attributes
OUT1.S	NUMBER X 1000 RELAY CYCLES	INFO	R
If output 1 is relay or logic, the parameter shows the number of switchings (in thousands). <b>Unit of measurement:</b> Number (× 1000) <b>Options:</b> -			

### 4.4.19. OUT2.S - Number of switchings output 2

Acronym	Scrolling message	Submenu	Attributes
OUT2.S	NUMBER X 1000 RELAY CYCLES	INFO	R
If output 2 is available on the controller, and if it is relay or logic, the parameter shows the number of switchings (in thousands). <b>Unit of measurement:</b> Number (× 1000) <b>Options:</b> -			

### 4.4.20. OUT3.S - Number of switchings output 3

Acronym	Scrolling message	Submenu	Attributes
OUT3.S	NUMBER X 1000 RELAY CYCLES	INFO	R
If output 3 is available on the controller, the parameter shows the number of switchings (in thousands). <b>Unit of measurement:</b> Number (× 1000) <b>Options:</b> -			

## 4.4.21. OUT4.S - Number of switchings output 3

Acronym	Scrolling message	Submenu	Attributes
OUT4.S	NUMBER X 1000 RELAY CYCLES	INFO	R
<p>If output 4 is available on the controller, the parameter shows the number of switchings (in thousands).</p> <p><b>Unit of measurement:</b> Number (× 1000)</p> <p><b>Options:</b> -</p>			

## 4.4.22. T.DAYS - Total working days

Acronym	Scrolling message	Submenu	Attributes
T.DAYS	TOTAL DAYS OF OPERATION	INFO	R
<p>The parameter shows total number of working days of the controller since first power-on. Each working day equals 24 hours of actual functioning.</p> <p><b>Unit of measurement:</b> Day</p> <p><b>Options:</b> 0...9999</p>			

## 4.4.23. P.DAYS - Partial working days

Acronym	Scrolling message	Submenu	Attributes
P.DAYS	PARTIAL DAYS OF OPERATION	INFO	R
<p>The parameter shows the number of working days of the controller since the last counter reset, Each working day equals 24 hours of actual functioning.</p> <p>The counter can be reset with the Us.cal function.</p> <p><b>Unit of measurement:</b> Day</p> <p><b>Options:</b> 0...9999</p>			

## 4.4.24. T.INT - Internal temperature of controller

Acronym	Scrolling message	Submenu	Attributes
T.INT	INTERNAL TEMPERATURE	INFO	R
<p>The parameter shows the instantaneous internal temperature of the controller.</p> <p><b>Unit of measurement:</b> °C</p> <p><b>Options:</b> -</p>			

## 4.4.25. T.MIN - Minimum internal temperature of the controller

Acronym	Scrolling message	Submenu	Attributes
T.MIN	MIN INTERNAL TEMPERATURE	INFO	R
<p>The parameter shows the minimum internal temperature of the controller measured during work.</p> <p><b>Unit of measurement:</b> °C</p> <p><b>Options:</b> -</p>			

## 4. CONFIGURATION

---

### 4.4.26. T.MAX - Maximum internal temperature of the controller

Acronym	Scrolling message	Submenu	Attributes
T.MAX	MAX INTERNAL TEMPERATURE	INFO	R

The parameter shows the maximum internal temperature of the controller measured during work.

**Unit of measurement:** °C

**Options:** -

### 4.4.27. tiME - Internal time

Acronym	Scrolling message	Submenu	Attributes
tiME	INTERNAL TIME	INFO	R

The parameter shows the internal time in 24-hour format. Hours, minutes and seconds are shown with scrolling text: hours, minutes and seconds.

**Unit of measurement:** hh:mm:ss

**Options:** -

### 4.4.28. dAtE - Internal date

Acronym	Scrolling message	Submenu	Attributes
dAtE	INTERNAL DATE	INFO	R

The parameter shows the complete internal date of the controller: month, day, year, day of week, with scrolling text.

**Unit of measurement:** MM / DD / YYYY

**Options:** -

### 4.5. PR.OPT Submenu - Configuring programs

Acronym	Scrolling message	Password	Description
PR.OPT	PROGRAMMER CONFIGURATION	Levelo	<p>Lets you configure the 4 programs manageable by the programmer. The parameters are configured for each program to be used. The Programmer function must first be enabled with the menu MODE, parameter PROGR = On.</p> <p>If "Simplified Programmer" mode is active (S.PROG parameter set to ON in the MODE Menu), the controller can manage 4 programs, each of which has up to 8 configurable steps.</p> <p>For more information on configuring the programmer, see paragraph "5.13. Setpoint programmer" on page 157.</p>

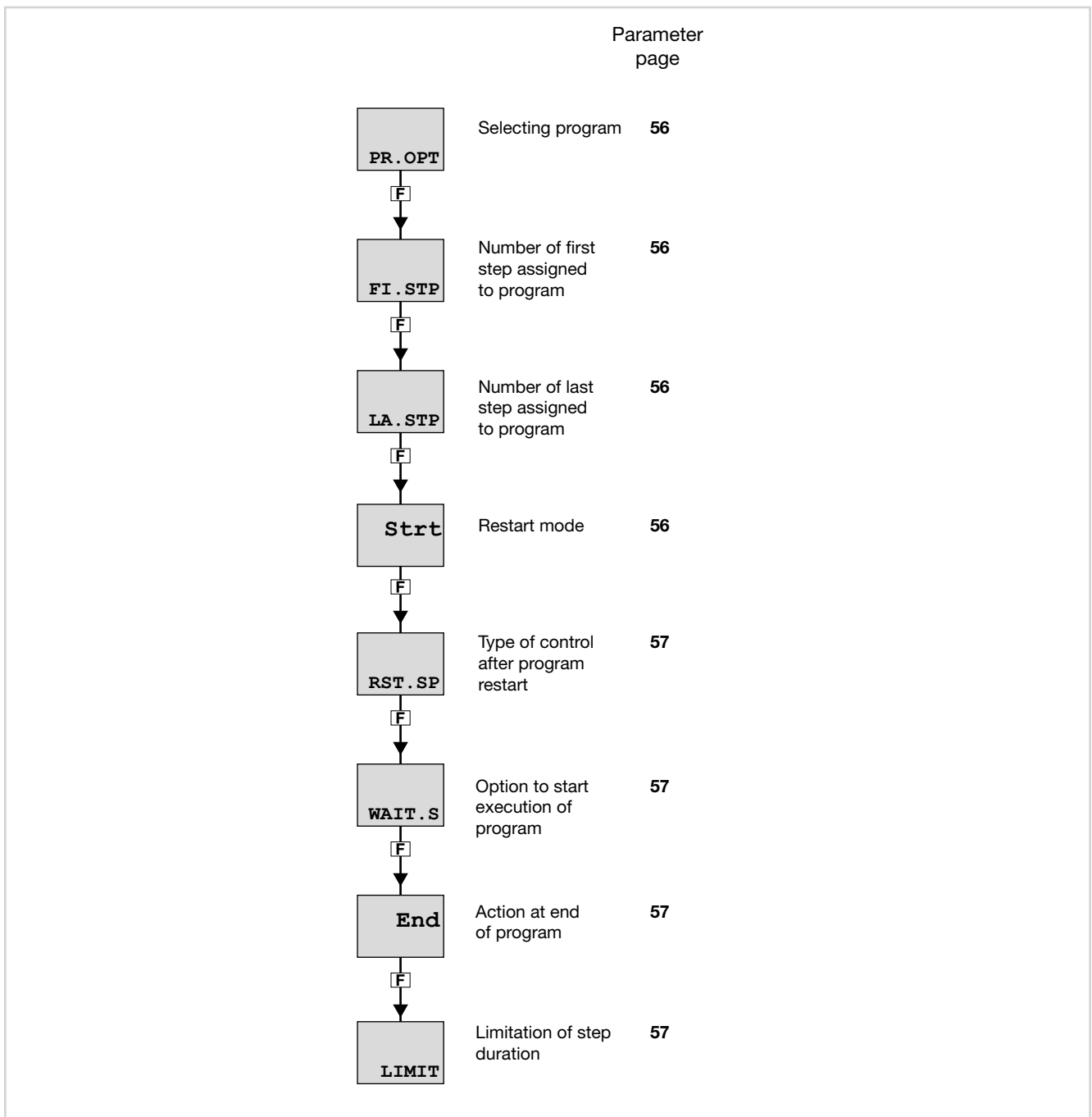

## 4. CONFIGURATION

### 4.5.1. PR.OPT - Selecting program

Acronym	Scrolling message	Submenu	Attributes
PR.OPT	PROGRAM NUMBER	PR.OPT	R W
<p>The parameter lets you select the program to be configured. During normal functioning, the controller shows the number of the program running and its state P.STAT, viewable in the User Configuration menu.</p> <p><b>Unit of measurement:</b> Number</p> <p><b>Options:</b> 1...4</p>			

### 4.5.2. FI.STP - Number of first step assigned to program

Acronym	Scrolling message	Submenu	Attributes
FI.STP	FIRST STEP OF PROGRAM	PR.OPT	R W
<p>The parameter lets you select the first step of the program.  <i>This parameter is visible only if "Simplified Programmer" is deactivated (S.PROG parameter set to OFF)</i></p> <p><b>Unit of measurement:</b> Number</p> <p><b>Options:</b> 1...32</p>			

### 4.5.3. LA.STP - Number of last step assigned to program

Acronym	Scrolling message	Submenu	Attributes
LA.STP	LAST STEP OF PROGRAM	PR.OPT	R W
<p>The parameter lets you select the last step of the program.  <i>This parameter is visible only if "Simplified Programmer" is deactivated (S.PROG parameter set to OFF)</i></p> <p>ATTENTION: LA.STP cannot be less than FI.STP.</p> <p><b>Unit of measurement:</b> Number</p> <p><b>Options:</b> 1...32</p>			

### 4.5.4. Strt - Restart mode

Acronym	Scrolling message	Submenu	Attributes
Strt	RESTART TYPE AFTER POWER-ON	PR.OPT	R W
<p>The parameter defines program restart mode after Power-on.</p> <p><b>Unit of measurement:</b> -</p> <p><b>Options:</b></p> <ul style="list-style-type: none"> <li><b>FI.STP</b> = Program restarts from first step, with setpoint attributed or equal to PV based on the following parameter RST.SP.ATTENTION: the programme positions itself in the READY state and waits for the START sequence to go to RUN - it does not restart automatically.</li> <li><b>ST.STP</b> = Program restarts from condition in which it stopped (last step in execution, setpoint - it does not need the START sequence</li> <li><b>RSRCH</b> = Program restarts with search for step (see programmer function...) - it does not need the START sequence.</li> </ul>			

## 4.5.5. RST.SP - Type of control after program restart

Acronym	Scrolling message	Submenu	Attributes
RST.SP	CONTROL TYPE AFTER RESET	PR.OPT	R W
<p>The parameter defines the type of control that the controller runs after a reset while waiting for restart. With RST.SP = On the setpoint takes the value of PV with reset command active.</p> <p><b>Unit of measurement:</b> -</p> <p><b>Options:</b>           <b>OFF</b> = The controller continues the control, maintaining the active setpoint                            <b>On</b> = The setpoint assumes the value of the process variable (PV) by imposing the control output to zero.</p>			

## 4.5.6. WAIT.S - Option to start execution of program

Acronym	Scrolling message	Submenu	Attributes
WAIT.S	DEF OF START EXEC PROGRAM	PR.OPT	R W
<p>Il parametro abilita o disabilita l'esecuzione automatica del reset della base tempi del programma dopo una commutazione STOP/START.</p> <p><b>Unit of measurement:</b> -</p> <p><b>Options:</b>           <b>OFF</b> = Disables automatic execution                            <b>On</b> = Enables automatic execution</p>			

## 4.5.7. End - Action at end of program

Acronym	Scrolling message	Submenu	Attributes
End	CONDITION AT END OF CYCLE	PR.OPT	R W
<p>The parameter defines what happens when the program in execution ends (last step done).</p> <p><b>Unit of measurement:</b> -</p> <p><b>Options:</b>           <b>NONE</b> = Nothing happens. The controller continues control                            <b>rESE</b> = switching in the RESET state, the control type will depend on the parameter RST.SP                            <b>LOOP</b> = The program restarts from the first step                            <b>OFF</b> = The program ends and puts the controller in the OFF position, with control output to zero</p>			

## 4.5.8. LIMIT - Limitation of step duration

Acronym	Scrolling message	Submenu	Attributes
LIMIT	DEF OF STEP TIMING LIMITATION	PR.OPT	R W
<p>The parameter enables or disables limitation of step duration. It is useful for quick execution of the program. Eventuale HBB è disabilitato e l'uscita di controllo è forzate al valore di FAULT.</p> <p><b>Unit of measurement:</b> -</p> <p><b>Options:</b>           <b>OFF</b> = Disables limitation of step duration                            <b>On</b> = Enables limitation of step duration: limits ramp times to 20 seconds and hold times to 10 seconds, in order to have a step time that never exceeds 30 seconds.</p>			

## 4. CONFIGURATION

---

### 4.6. PR.STP Submenu - Configuration of program steps

---

Acronym	Scrolling message	Password	Description
PR.STP	STEP DEFINITION	Level 1	<p>Lets you configure the steps that make up the program. The parameters are configured for each step to be used. The Programmer function must first be enabled with the MODE menu, parameter PROGR = On.</p> <p>For more information on configuring the programmer, see paragraph "5.13. Setpoint programmer" on page 157.</p>

Submenu PR.STP - Configuration of program steps

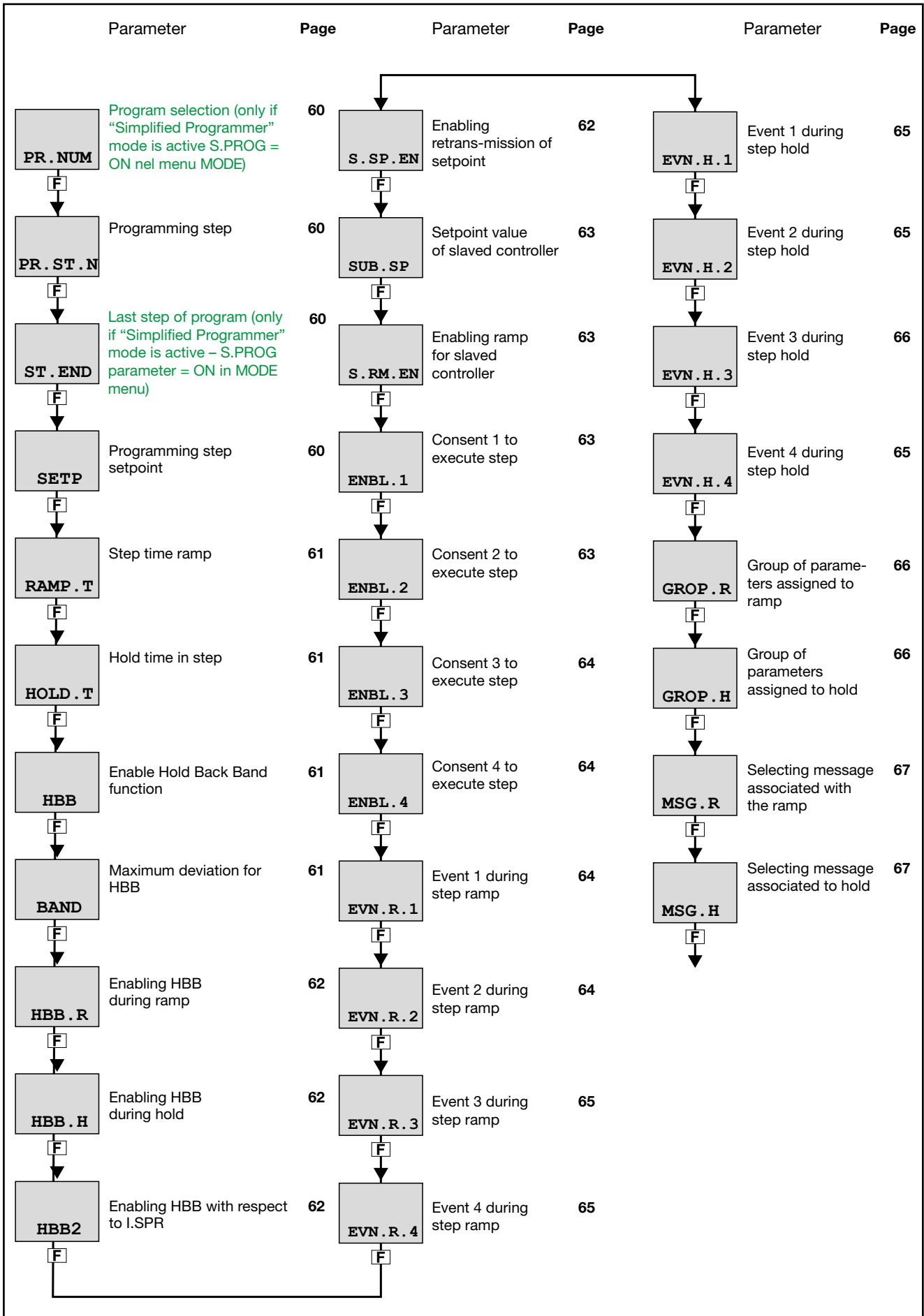

## 4. CONFIGURATION

### 4.6.1. PR.NUM

Acronym	Scrolling message	Submenu	Attributes
PR.NUM	PROGRAMMER ACTUAL PROGRAM	PR.SPT	R W
<p>This parameter shows and sets the program number that you intend to modify. Appears only if “Simplified Programmer” mode is selected - parameter S.PROG = ON).</p> <p><b>Unit of measurement:</b> Program number</p> <p><b>Options:</b> 1...4</p>			

### 4.6.2. PR.ST.N - Programming step

Acronym	Scrolling message	Submenu	Attributes
PR.ST.N	PROGRAMMER ACTUAL STEP	PR.STP	R W
<p>The parameter shows and sets the number of the programming step being configured. Appears only if simplified programming mode is selected.</p> <p><b>Unit of measurement:</b> Number step</p> <p><b>Options:</b> 1...32 se S.PROG = OFF; 8 se S.PROG = ON (“Simplified Programmer” mode)</p>			

### 4.6.3. ST.END - Setting the final step in the program

Acronym	Scrolling message	Submenu	Attributes
ST.END	PR.STP.1 (or PR.STP.2... PR.STP.32) END STEP OF THE PROGRAM if “Simplified Programmer” mode is disabled; (or PR.STP.1 ... PR.STP.8) END STEP OF THE PROGRAM if “Simplified Programmer” mode is active	PR.STP	R W
<p>This parameter shows and sets the current step as the last step in the program selected by the PR.NUM. parameter. Appears only if simplified programming mode is selected.</p> <p><b>Unit of measurement:</b> -</p> <p><b>Options:</b> <b>No</b> = the current step is not the last in the program selected by the PR.NUM parameter <b>YES</b> = the current step is the last in the program selected by the PR.NUM parameter</p>			

### 4.6.4. SETP - Programming step setpoint

Acronym	Scrolling message	Submenu	Attributes
SETP	PR.STP.1 (or PR.STP.2... PR.STP.32) SETPOINT if “Simplified programmer” mode is turned off; o PR.STP.1... PR.STP.8 SETPOINT if “Simplified programmer” mode is turned on.	PR.SPT	R W
<p>The parameter shows and sets the setpoint for the current programming step. The selectable values are between the low setpoint (LO.SP) and the high setpoint (HI.SP), settable with submenu I.MAIN.</p> <p><b>Unit of measurement:</b> °C, °F, % based on chosen scale</p> <p><b>Options:</b> LO.SP...HI.SP</p>			

## 4.6.5. RAMP.T - Step time ramp

Acronym	Scrolling message	Submenu	Attributes
RAMP.T	PR.STP.1 (or PR.STP.2...PR.STP.32) STEP RAMP TIME if “Simplified programmer” mode is turned off; or PR.STP.1...PR.STP.8 STEP RAMP TIME if “Simplified programmer” mode is turned on.	PR.SPT	R W
<p>The parameter shows and sets the time taken to go from the previous setpoint to the setpoint of the current programming step.</p> <p><b>Unit of measurement:</b> hh.mm or mm.ss (hours.minutes or minutes.seconds). Depends on time base set with submenu MODE, parameter t.Pro</p> <p><b>Options:</b> 00.00...99.59</p>			

## 4.6.6. HOLD.T - Hold time in step

Acronym	Scrolling message	Submenu	Attributes
HOLD.T	PR.STP.1 (or PR.STP.2...PR.STP.32) STEP HOLD TIME if “Simplified programmer” mode is turned off; or PR.STP.1...PR.STP.8 STEP HOLD TIME if “Simplified programmer” mode is turned on.	PR.SPT	R W
<p>The parameter shows and sets the time the program waits before going to the next step.</p> <p><b>Unit of measurement:</b> hh.mm or mm.ss (ore.minuti o minuti.secondsi). Depends on time base set with submenu MODE, parameter t.Pro</p> <p><b>Options:</b> 00.00...99.59</p>			

## 4.6.7. HBB - Enable Hold Back Band function

Acronym	Scrolling message	Submenu	Attributes
HBB	PR.STP.1 (or PR.STP.2...PR.STP.32) HOLD BACK BAND FUNCTION if “Simplified programmer” mode is turned off; or PR.STP.1...PR.STP.8 HOLD BACK BAND FUNCTION if “Simplified programmer” mode is turned on.	PR.SPT	R W
<p>The parameter enables and disables the Hold Back Band function</p> <p>The HBB function checks that the variable remains in the required tolerance interval. If the maximum deviation is exceeded, the program time base is stopped. The function is settable independently for each programming step. In addition, it can be enabled for the time ramp only, for the hold time only, or for both.</p> <p><b>Unit of measurement:</b> -</p> <p><b>Options:</b>       <b>OFF</b>   = Disables HBB function                   <b>On</b>     = Enables HBB function</p>			

## 4.6.8. BAND - Maximum deviation for HBB

Acronym	Scrolling message	Submenu	Attributes
BAND	PR.STP.1 (or PR.STP.2...PR.STP.32) HOLD BACK BAND VALUE if “Simplified programmer” mode is turned off; or PR.STP.1...PR.STP.8 HOLD BACK BAND VALUE if “Simplified programmer” mode is turned on.	PR.SPT	R W
<p>If the HBB function is enabled, the parameter shows and sets the maximum deviation allowed for PV compared to SV.</p> <p><b>Unit of measurement:</b> °C, °F, % based on chosen scale</p> <p><b>Options:</b> 0...999</p>			

## 4. CONFIGURATION

### 4.6.9. HBB.R - Enabling HBB during ramp

Acronym	Scrolling message	Submenu	Attributes
HBB.R	PR.STP.1 (or PR.STP.2...PR.STP.32) ENABLE HOLD BACK BAND DURING STEP RAMP if "Simplified programmer" mode is turned off; or PR.STP.1...PR.STP.8 HOLD BACK BAND DURING STEP RAMP if "Simplified programmer" mode is turned on.	PR.SPT	R W
<p>If the HBB function is enabled, the parameter enables and disables it during the step ramp time.</p> <p><b>Unit of measurement:</b> -</p> <p><b>Options:</b>           <b>OFF</b> = Disables HBB function during ramp time                            <b>On</b> = Enables HBB function during ramp time</p>			

### 4.6.10. HBB.H - Enabling HBB during hold

Acronym	Scrolling message	Submenu	Attributes
HBB.H	PR.STP.1 (or PR.STP.2...PR.STP.32) ENABLE HOLD BACK BAND DURING STEP HOLD if "Simplified programmer" mode is turned off; or PR.STP.1...PR.STP.8 ENABLE HOLD BACK BAND DURING STEP HOLD if "Simplified programmer" mode is turned on.	PR.SPT	R W
<p>If the HBB function is enabled, the parameter enables and disables it during hold in the step.</p> <p><b>Unit of measurement:</b> -</p> <p><b>Options:</b>           <b>OFF</b> = Disables HBB function during hold in step                            <b>On</b> = Enables HBB function during hold in step</p>			

### 4.6.11. HBB2 - Enabling HBB with respect to I.SPR

Acronym	Scrolling message	Submenu	Attributes
HBB2	PR.STP.1 (or PR.STP.2...PR.STP.32) HOLD BACK BAND REFERRED TO I.SPR INPUT if "Simplified programmer" mode is turned off; or PR.STP.1...PR.STP.8 HOLD BACK BAND REFERRED TO I.SPR INPUT if "Simplified programmer" mode is turned on.	PR.SPT	R W
<p>If the HBB function is enabled, the parameter enables and disables it with respect to the remote setpoint input, which can be enabled on the MODE submenu, SP.REM parameter = On and submenu I.SPR, parameter F.SPr = SETP  When the function is enabled with respect to the remote setpoint, if deviation PV-SPR exceeds value BAND, the program time base is stopped.</p> <p><b>Unit of measurement:</b> -</p> <p><b>Options:</b>           <b>OFF</b> = Disables HBB function with respect to remote setpoint input                            <b>On</b> = Enables HBB function with respect to remote setpoint input</p>			

### 4.6.12. S.SP.EN - Enabling retransmission of setpoint

Acronym	Scrolling message	Submenu	Attributes
S.SP.EN	PR.STP.1 (or PR.STP.2...PR.STP.32) SUBDUED SETPOINT RETRANSMITTED ENABLE if "Simplified programmer" mode is turned off; or PR.STP.1...PR.STP.8 SUBDUED SETPOINT RETRANSMITTED ENABLE if "Simplified programmer" mode is turned on.	PR.SPT	R W
<p>The parameter enables and disables retransmission of the setpoint value to other slaved controllers.  The set point value is sent by configured analog output A1, OUT.AN submenu, parameter F.o.A1 = SLV.SP.</p> <p><b>Unit of measurement:</b> -</p> <p><b>Options:</b>           <b>OFF</b> = Disables retransmission                            <b>On</b> = Enables retransmission</p>			

## 4.6.13. SUB.SP - Setpoint value of slaved controller

Acronym	Scrolling message	Submenu	Attributes
SUB.SP	PR.STP.1 (or PR.STP.2...PR.STP.32) SUBDUED SETPOINT ASSOCIATED TO STEP if "Simplified programmer" mode is turned off; or PR.STP.1...PR.STP.8 SUBDUED SETPOINT ASSOCIATED TO STEP if "Simplified programmer" mode is turned on.	PR.SPT	R W
<p>If the S.SP.EN function is enabled, the parameter shows and sets the setpoint value to be retransmitted as a percentage of the controller setpoint value</p> <p>EXAMPLE If the setpoint of the main controller is 180°C and you want the setpoint of the secondary controller to be 85°C, then SUB.SP should be set to 47.2 (47.2% of 180 is about 85).</p> <p><b>Unit of measurement:</b> %</p> <p><b>Options:</b> 0.0...100.0</p>			

## 4.6.14. S.RM.EN - Enabling ramp for slaved controller

Acronym	Scrolling message	Submenu	Attributes
S.RM.EN	SUBDUED SETPOINT RAMP ENABLE	PR.SPT	R W
<p>If the S.SP.EN function is enabled, the parameter enables and disables the setpoint ramp for the slaved controller.</p> <p><b>Unit of measurement:</b> -</p> <p><b>Options:</b> OFF = Disables setpoint ramp for slaved controller On = Enables setpoint ramp for slaved controller</p>			

## 4.6.15. ENBL.1 - Consent 1 to execute step

Acronym	Scrolling message	Submenu	Attributes
ENBL.1	PR.STP.1 (or PR.STP.2...PR.STP.32) STEP ENABLE FOR STEP START if "Simplified programmer" mode is turned off; or PR.STP.1...PR.STP.8 STEP ENABLE FOR STEP START if "Simplified programmer" mode is turned on.	PR.SPT	R W
<p>The parameter shows and sets consent 1 condition to enable execution of the step.</p> <p>The consents automatically check that certain conditions have been met before the program continues. There are 4 different consents (1, 2, 3 and 4) and, at the start of the step, the state of each must match the programmed state.</p> <p>Consents can be set via digital inputs, function block outputs, and the RS485 serial input. If even one of the consents does not match the programmed state, the step is not executed. If all consents are set to nonE, execution of the step is not conditioned and is always executed.</p> <p><b>Unit of measurement:</b> -</p> <p><b>Options:</b> nonE = Consent state is ignored, i.e., step is always executed On = Consent must be on to execute step OFF = Consent does not have to be on to execute step</p>			

## 4.6.16. ENBL.2 - Consent 2 to execute step

Acronym	Scrolling message	Submenu	Attributes
ENBL.2	PR.STP.1 (or PR.STP.2...PR.STP.32) STEP ENABLE FOR STEP START if "Simplified programmer" mode is turned off; or PR.STP.1...PR.STP.8 STEP ENABLE FOR STEP START if "Simplified programmer" mode is turned on.	PR.SPT	R W
<p>The parameter shows and sets consent 2 condition to enable execution of the step.</p> <p>See ENBL.1 for details.</p>			

## 4. CONFIGURATION

### 4.6.17. ENBL.3 - Consent 3 to execute step

Acronym	Scrolling message	Submenu	Attributes
ENBL.3	PR.STP.1 (or PR.STP.2...PR.STP.32) STEP ENABLE FOR STEP START if "Simplified programmer" mode is turned off; or PR.STP.1...PR.STP.8 STEP ENABLE FOR STEP START if "Simplified programmer" mode is turned on.	PR.SPT	R W
The parameter shows and sets consent 3 condition to enable execution of the step.			
See ENBL.1 for details.			

### 4.6.18. ENBL.4 - Consent 4 to execute step

Acronym	Scrolling message	Submenu	Attributes
ENBL.4	PR.STP.1 (or PR.STP.2...PR.STP.32) STEP ENABLE FOR STEP START if "Simplified programmer" mode is turned off; or PR.STP.1...PR.STP.8 STEP ENABLE FOR STEP START if "Simplified programmer" mode is turned on.	PR.SPT	R W
The parameter shows and sets consent 4 condition to enable execution of the step.			
See ENBL.1 for details.			

### 4.6.19. EVN.R.1 - Event 1 during step ramp

Acronym	Scrolling message	Submenu	Attributes
EVN.R.1	PR.STP.1 (or PR.STP.2...PR.STP.32) EVENT DURING STEP RAMP if "Simplified programmer" mode is turned off; or PR.STP.1...PR.STP.8 EVENT DURING STEP RAMP if "Simplified programmer" mode is turned on.	PR.SPT	R W
The parameter shows and sets the configuration of event 1 during the step ramp.			
<b>Unit of measurement:</b> -			
<b>Options:</b>			
	<b>nonE</b>	= Event not modified	
	<b>On</b>	= Event becomes active	
	<b>OFF</b>	= Event becomes inactive	

### 4.6.20. EVN.R.2 - Event 2 during step ramp

Acronym	Scrolling message	Submenu	Attributes
EVN.R.2	PR.STP.1 (or PR.STP.2...PR.STP.32) EVENT DURING STEP RAMP if "Simplified programmer" mode is turned off; or PR.STP.1...PR.STP.8 EVENT DURING STEP RAMP if "Simplified programmer" mode is turned on.	PR.SPT	R W
The parameter shows and sets the configuration of event 2 during the step ramp			
<b>Unit of measurement:</b> -			
<b>Options:</b>			
	<b>nonE</b>	= Event not modified	
	<b>On</b>	= Event becomes active	
	<b>OFF</b>	= Event becomes inactive	

## 4.6.21. EVN.R.3 - Event 3 during step ramp

Acronym	Scrolling message	Submenu	Attributes
EVN.R.3	PR.STP.1 (or PR.STP.2...PR.STP.32) EVENT DURING STEP RAMP if “Simplified programmer” mode is turned off; or PR.STP.1...PR.STP.8 EVENT DURING STEP RAMP if “Simplified programmer” mode is turned on.	PR.SPT	R W
<p>The parameter shows and sets the configuration of event 3 during the step ramp.</p> <p><b>Unit of measurement:</b> -</p> <p><b>Options:</b>           <b>nonE</b> = Event not modified                            <b>On</b>    = Event becomes active                            <b>OFF</b>   = Event becomes inactive</p>			

## 4.6.22. EVN.R.4 - Event 3 during step ramp

Acronym	Scrolling message	Submenu	Attributes
EVN.R.4	PR.STP.1 (or PR.STP.2...PR.STP.32) EVENT DURING STEP RAMP if “Simplified programmer” mode is turned off; or PR.STP.1...PR.STP.8 EVENT DURING STEP RAMP if “Simplified programmer” mode is turned on.	PR.SPT	R W
<p>The parameter shows and sets the configuration of event 4 during the step ramp..</p> <p><b>Unit of measurement:</b> -</p> <p><b>Options:</b>           <b>nonE</b> = Event not modified                            <b>On</b>    = Event becomes active                            <b>OFF</b>   = Event becomes inactive</p>			

## 4.6.23. EVN.H.1 - Event 1 during step hold

Acronym	Scrolling message	Submenu	Attributes
EVN.H.1	PR.STP.1 (or PR.STP.2...PR.STP.32) EVENT DURING STEP HOLD if “Simplified programmer” mode is turned off; or PR.STP.1...PR.STP.8 EVENT DURING STEP HOLD if “Simplified programmer” mode is turned on.	PR.SPT	R W
<p>The parameter shows and sets the configuration of event 1 during the step hold.</p> <p><b>Unit of measurement:</b> -</p> <p><b>Options:</b>           <b>nonE</b> = Event not modified                            <b>On</b>    = Event becomes active                            <b>OFF</b>   = Event becomes inactive</p>			

## 4.6.24. EVN.H.2 - Event 2 during step hold

Acronym	Scrolling message	Submenu	Attributes
EVN.H.2	PR.STP.1 (or PR.STP.2...PR.STP.32) EVENT DURING STEP HOLD if “Simplified programmer” mode is turned off; or PR.STP.1...PR.STP.8 EVENT DURING STEP HOLD if “Simplified programmer” mode is turned on.	PR.SPT	R W
<p>The parameter shows and sets the configuration of event 2 during the step hold.</p> <p><b>Unit of measurement:</b> -</p> <p><b>Options:</b>           <b>nonE</b> = Event not modified                            <b>On</b>    = Event becomes active                            <b>OFF</b>   = Event becomes inactive</p>			

## 4. CONFIGURATION

### 4.6.25. EVN.H.3 - Event 3 during step hold

Acronym	Scrolling message	Submenu	Attributes
EVN.H.3	EVENT DURING STEP HOLD	PR.SPT	R W
<p>The parameter shows and sets the configuration of event 3 during the step hold.</p> <p><b>Unit of measurement:</b> -</p> <p><b>Options:</b>            <b>nonE</b> = Event not modified                            <b>On</b>    = Event becomes active                            <b>OFF</b>   = Event becomes inactive</p>			

### 4.6.26. EVN.H.4 - Event 4 during step hold

Acronym	Scrolling message	Submenu	Attributes
EVN.H.4	PR.STP.1 (or PR.STP.2...PR.STP.32) EVENT DURING STEP HOLD if “Simplified programmer” mode is turned off; or PR.STP.1...PR.STP.8 EVENT DURING STEP HOLD if “Simplified programmer” mode is turned on.	PR.SPT	R W
<p>The parameter shows and sets the configuration of event 4 during the step hold.</p> <p><b>Unit of measurement:</b> -</p> <p><b>Options:</b>            <b>nonE</b> = Event not modified                            <b>On</b>    = Event becomes active                            <b>OFF</b>   = Event becomes inactive</p>			

### 4.6.27. GROP.R - Group of parameters assigned to ramp

Acronym	Scrolling message	Submenu	Attributes
GROP.R	PR.STP.1 (or PR.STP.2...PR.STP.32) CONTROL PARAMETER GROUP DURING STEP RAMP if “Simplified programmer” mode is turned off; or PR.STP.1...PR.STP.8 CONTROL PARAMETER GROUP DURING STEP RAMP if “Simplified programmer” mode is turned on.	PR.SPT	R W
<p>The parameter shows and sets the group of control parameters assigned to the step during the ramp.  PID.G.N is settable on the MODE submenu.</p> <p><b>Unit of measurement:</b>    Number</p> <p><b>Options:</b>                <b>0...PID.G.N</b> = Number of group. If 0, parameters are those for controller settable on PID submenu</p>			

### 4.6.28. GROP.H - Group of parameters assigned to hold

Acronym	Scrolling message	Submenu	Attributes
GROP.H	PR.STP.1 (or PR.STP.2...PR.STP.32) CONTROL PARAMETER GROUP DURING STEP HOLD if “Simplified programmer” mode is turned off; or PR.STP.1...PR.STP.8 CONTROL PARAMETER GROUP DURING STEP HOLD if “Simplified programmer” mode is turned on.	PR.SPT	R W
<p>The parameter shows and sets the group of control parameters assigned to the step during the hold.  PID.G.N is settable on the MODE submenu.</p> <p><b>Unit of measurement:</b>    Number</p> <p><b>Options:</b>                <b>0...PID.G.N</b> = Number of group. If 0, parameters are those for controller settable on PID submenu</p>			

## 4.6.29. MSG.R - Message associated with the ramp

Acronym	Scrolling message	Submenu	Attributes
MSG.R	PR.STP.1 (or PR.STP.2...PR.STP.32) SCROLLING MESSAGE DURING STEP RAMP if “Simplified programmer” mode is turned off; or PR.STP.1...PR.STP.8 SCROLLING MESSAGE DURING STEP RAMP if “Simplified programmer” mode is turned on.	PR.SPT	R W
<p>The parameter displays and sets the message number associated with the step during the ramp, which is the message that will appear on the display to scroll to the step you are configuring            More information on the scrolling message can be found in the section “3.1.2.2 Scrolling messages” on page 34.            Setting it to “0” will not show any messages.</p> <p><b>Unit of measurement:</b> ID number of the message</p> <p><b>Options:</b> 0...25</p>			

## 4.6.30. MSG.H - Message associated with the maintenance

Acronym	Scrolling message	Submenu	Attributes
MSG.H	PR.STP.1 (or PR.STP.2...PR.STP.32) SCROLLING MESSAGE DURING STEP HOLD if “Simplified programmer” mode is turned off; or PR.STP.1...PR.STP.8 SCROLLING MESSAGE DURING STEP HOLD if “Simplified programmer” mode is turned on.	PR.SPT	R W
<p>The parameter displays and sets the message number associated with the pitch during the maintenance, which is the message that will appear on the display to scroll to the step you are configuring            More information on the scrolling message can be found in the section “3.1.2.2 Scrolling messages” on page 34.            Setting it to “0” will not show any messages.</p> <p><b>Unit of measurement:</b> ID number of the message</p> <p><b>Options:</b> 0...25</p>			

## 4. CONFIGURATION

### 4.7. I.MAIN Submenu - Configuration of main input

Acronym	Scrolling message	Password	Description
I.MAIN	MAIN INPUT CONFIG	Level 1	Lets you configure the controller's main input.

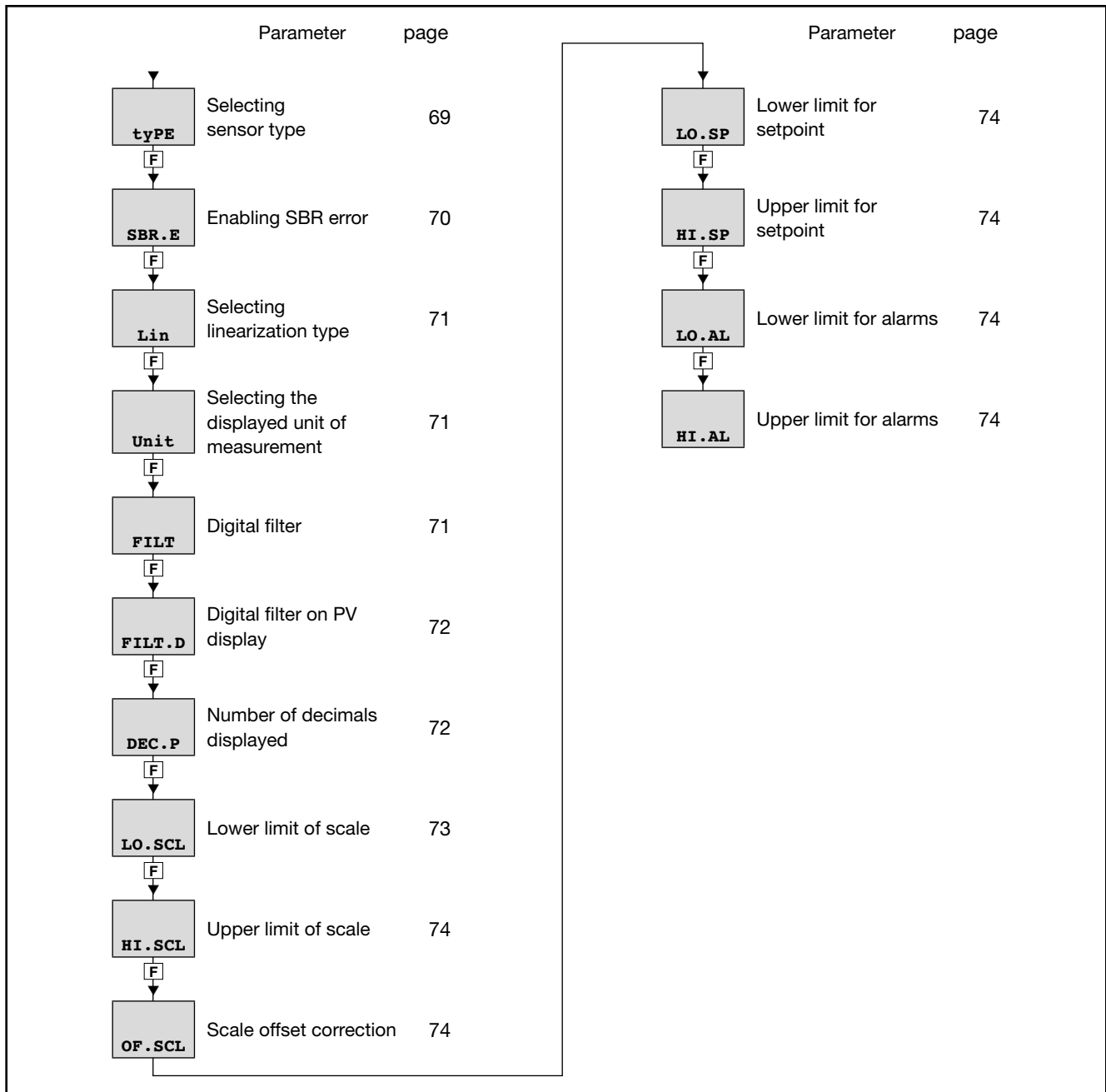

## 4.7.1. tyPE - Selecting sensor type

Acronym	Scrolling message	Submenu	Attributes
tyPE	MAIN INPUT TYPE OF PROBE	I.MAIN	R W

The parameter shows and sets the sensor type of the main input.

The functions for calibrating Custom sensors are on the US.CAL menu.

When a 4...20 mA input is used and the current is less than 2 mA, an Err message is generated and the relay state specified with the FAULT parameters is activated.

The table shows the scale limits for each sensor type or input based on the set number of decimals.

Sensor type	Sensor	Unit of measurement	Scale limits for DEC.P = 0	Scale limits for DEC.P = 1	Error @ 25°C
Thermocouple	J	°C	0...1000	0.0...999.9	< 1,6°C
	K	°C	0...1300	0.0...999.9	
	R	°C	0...1750	0.0...999.9	with scale 0...1750 °C: < 2°C
	S	°C	0...1750	0.0...999.9	(T > 100 °C)
	T	°C	-200...400	-199.9...400.0	< 1,6°C
	C	°C	0...2300	0.0...999.9	< 1,6°C
	D	°C	0...2300	0.0...999.9	< 1,6°C
	B	°C	44...1800	n.d.	
	E	°C	-100...750	-100.0...750.0	
	L	°C	-200...900	-199.9...900.0	
	L-GOST	°C	0...600	0.0...600.0	
	U	°C	-200...400	-199.9...4900.0	
	G	°C	0...2300	n.d.	
	N	°C	0...1300	0.0...999.9	
Pt20Rh Pt40Rh	°C	0...1880	0.0...999.9	< 5,1°C (T>1000°C)	
Infrared characteristic of the Tc K model see note	1	°C	10...70	10.0...70.0	maximum error 0.5°C
	2	°C	60...120	60.0...120.0	maximum error 0.5°C
	3	°C	115...165	115.0...165.0	maximum error 0.5°C
	4	°C	140...260	140.0...260.0	maximum error 0.5°C
Resistance thermometer	PT100	°C	-200...850	-199.9...850.0	< 1°C
	PT100	°C	-50...250	-50.0...250.0	
	JPT100	°C	-200...600	-199.9...850.0	< 1°C
Voltage /Current	0...60 mV				
	0...20 mA				
	4...20 mA				
	0...10 V		-1999...9999	-199.9...999.9	
	2...10 V				
	0...5 V				
	1...5 V				
	0...1 V				
0.2...1 V					
Custom	RTD				
	0...60 mV		-1999...9999	-199.9...999.9	
	0...20 mA				
	4...20 mA				
	0...10 V				
	2...10 V				
	0...5 V				
	1...5 V				
	0...1 V				
0.2...1 V					

**Nota:** the infrared temperature sensor has an output in voltage for direct connection to the input terminals of the temperature controller. An external thermometer is needed in order to correct the sensor error.

After identifying the work temperature range (for example, 140 – 260°C), set an SP near the minimum scale value, and after reaching it make a note of value A1 indicated by the instrument and of value A2 indicated by the external thermometer. Set an SP near the maximum scale value, and after reaching it make a note of value B1 indicated by the instrument and of value B2 indicated by the external thermometer. Enable 4-point linearization (see Correcting 4-point input) and enter the four requested values (A1, B1 and A2, B2)..

## 4. CONFIGURATION

<b>Unit of measurement:</b>	-
<b>Options:</b>	<p> <b>J.TC</b> = J thermocouple  <b>K.TC</b> = K thermocouple  <b>R TC</b> = R thermocouple  <b>S TC</b> = S thermocouple  <b>T.TC</b> = T thermocouple  <b>C.TC</b> = C thermocouple  <b>D.TC</b> = D thermocouple  <b>B.TC</b> = B thermocouple  <b>E.TC</b> = E thermocouple  <b>L.TC</b> = L thermocouple  <b>L.GO.TC</b> = L.GOST thermocouple  <b>U.TC</b> = U thermocouple  <b>G.TC</b> = G thermocouple  <b>N.TC</b> = N thermocouple  <b>PT2.TC</b> = Pt20Rh / Pt40Rh thermocouple  <b>INFR1</b> = IR sensor type 1  <b>INFR2</b> = IR sensor type 2  <b>INFR3</b> = IR sensor type 3  <b>INFR4</b> = IR sensor type 4  <b>PT100</b> = Pt100 resistance thermometer  <b>PT.LIM</b> = Pt 100 limited resistance thermometer  <b>JTP10</b> = JPT100 resistance thermometer  <b>60MV</b> = 0...60 mV sensor  <b>20MA</b> = 0...20 mA sensor  <b>4-20M</b> = 4...20 mA sensor  <b>10V</b> = 0...10 V sensor  <b>2-10V</b> = 2...10 V sensor  <b>5V</b> = 0...5 V sensor  <b>1-5V</b> = 1...5 V sensor  <b>1V</b> = 0...1 V sensor  <b>0.2-1V</b> = 0,2...1 V sensor  <b>C.RTD</b> = RTD sensor with user calibration  <b>C.60MV</b> = 0...60 mV sensor with user calibration  <b>C.20MA</b> = 0...20 mA sensor with user calibration  <b>C.4-20</b> = 4...20 mA sensor with user calibration  <b>C.10V</b> = 0...10 V sensor with user calibration  <b>C.2-10</b> = 2...10 V sensor with user calibration  <b>C.5V</b> = 0...5 V sensor with user calibration  <b>C.1-5V</b> = 1...5 V sensor with user calibration  <b>C.1V</b> = 0...1 V sensor with user calibration  <b>C.0.2-1</b> = 0,2...1 V sensor with user calibration </p>

### 4.7.2. SBR.E - Enabling SBR error

Acronym	Scrolling message	Submenu	Attributes
SBR.E	INPUT.1 (o INPUT.2) SBR ENABLE	HMI	R W
<p>Enables open thermocouple probe error detection, also permitting infrared sensor management with maximum 4Kohm output impedance.</p> <p>This parameter only appears when a thermocouple type input is selected.</p> <p>When OFF, the parameter will be forced to ON (see options) at each Power On</p> <p><b>Unit of measurement:</b> -</p> <p><b>Options:</b>           <b>OFF</b> = Disable SBR alarm</p>			

## 4.7.3. Lin - Selecting linearization type

Acronym	Scrolling message	Submenu	Attributes
Lin	CUSTOM LINEARIZATION	I.MAIN	R W
<p>The parameter sets linearization for the selected sensor type. The function corrects any linearity and proportionality errors in the correlation between the value sent by the input and the actual value of the physical quantity measured.</p> <div style="text-align: center;"> </div> <p>This correction can be made with two different algorithms: 32-step linearization and 4-point linearization. Values are set (33 for 32-step linearization and 4 for 4-point linearization) with the LINRZ submenu parameters.</p> <p>For an explanation of 4-point linearization, see paragraph "5.4. 4-point input correction" on page 149.</p> <p><b>Unit of measurement:</b> -</p> <p><b>Options:</b></p> <ul style="list-style-type: none"> <li><b>NONE</b> = No linearization</li> <li><b>32.STP</b> = 32-step linearization</li> <li><b>4.POIN</b> = 4-point linearization</li> </ul>			

## 4.7.4. Unit - Selecting the displayed unit of measurement

Acronym	Scrolling message	Submenu	Attributes
Unit	UNIT OF MEASURE	I.MAIN	R W
<p>The parameter shows and sets the unit of measurement displayed for input 1. The unit appears on the Home page of the display.</p> <p>For thermocouple or resistance thermometer inputs, the °C / °F selection automatically converts the temperature value; the related scale limits and setpoint limits must be set.</p> <p><b>Unit of measurement:</b> -</p> <p><b>Options:</b></p> <ul style="list-style-type: none"> <li><b>NONE</b> = No unit of measurement</li> <li><b>°C</b> = Degrees Celsius</li> <li><b>°F</b> = Degrees Fahrenheit</li> <li><b>CUST</b> = Custom, settable with GF_eXpress</li> </ul>			

## 4.7.5. FILT - Digital filter

Acronym	Scrolling message	Submenu	Attributes
FILT	DIGITAL FILTER	I.MAIN	R W
<p>The parameter shows and sets the value of the digital filter time constant. With 0.00 no filter is applied.</p> <p><b>Unit of measurement:</b> Seconds</p> <p><b>Options:</b> 0.00...20.00</p>			

## 4. CONFIGURATION

### 4.7.6. FILT.D - Digital filter on PV display

Acronym	Scrolling message	Submenu	Attributes
FILT.D	DIGITAL FILTER ON DISPLAY PV	I.MAIN	R W
<p>The parameter shows and sets the allowed tolerance between the real PV value and the value on the PV display: if the variation in real PV is within the interval displayed value - FILT.D... displayed value + FILT.D the displayed value does not change. With 0.00 no filter is applied..</p> <p><b>Unit of measurement:</b> The one set with the Unit parameter</p> <p><b>Options:</b> 0.0...9.9</p>			

### 4.7.7. DEC.P - Number of decimals displayed

Acronym	Scrolling message	Submenu	Attributes
DEC.P	DECIMAL POINT POSITION	I.MAIN	R W
<p>The parameter shows and sets the decimal point position for the process value (PV) displayed, i.e., defines its number of decimal figures. The number of decimal set may reduce the limits of the measurement scale used.</p> <p><b>Unit of measurement:</b> Number</p> <p><b>Options:</b> 0...3 = Number of decimals displayed 0 / 1 = Number of decimals displayed, only for TC and RTD sensors</p>			

## 4.7.8. LO.SCL - Lower limit of scale

Acronym	Scrolling message		Submenu	Attributes
LO.SCL	INPUT LOW LIMIT		I.MAIN	R W
<p>The parameter shows and sets the lower limit of the measurement scale used for the main input, based on input (or sensor) type, unit of measurement, and number of decimals selected. The upper value of LO.SCL is not limited by the value of HI.SCL</p> <p><b>Unit of measurement:</b> The one set with the Unit parameter</p> <p><b>Options:</b> A numerical value within the temperature range of the input or sensor</p>				
	Unit = °C DEC.P = 0	Unit = °F DEC.P = 0	Unit = °C DEC.P = 0	Unit = °F DEC.P = 0
<b>J.TC</b>	0...1000	32...1832	<b>4-20M</b>	-1999...9999
<b>K.TC</b>	0...1300	32...2372	<b>10V</b>	-1999...9999
<b>R TC</b>	0...1750	32...3182	<b>2-10V</b>	-1999...9999
<b>S TC</b>	0...1750	32...3182	<b>5V</b>	-1999...9999
<b>T.TC</b>	-200...400	-328...752	<b>1-5V</b>	-1999...9999
<b>C.TC</b>	0...2300	32...4172	<b>1V</b>	-1999...9999
<b>D.TC</b>	0...2300	32...4172	<b>0.2-1V</b>	-1999...9999
<b>B.TC</b>	44...1800	111...3272	<b>C.RTD</b>	-1999...9999
<b>E.TC</b>	-100...750	-145...1382	<b>C.60MV</b>	-1999...9999
<b>L.TC</b>	-200...900	-328...1652	<b>C.20MA</b>	-1999...9999
<b>L-GOST.TC</b>	0...600	32...1112	<b>C.4-20</b>	-1999...9999
<b>U.TC</b>	-200...400	-328...752	<b>C.10V</b>	-1999...9999
<b>G.TC</b>	0...2300	32...4172	<b>C.2-10</b>	-1999...9999
<b>N.TC</b>	0...1300	32...2372	<b>C.5V</b>	-1999...9999
<b>PT2.TC</b>	0...1880	32...4208	<b>C.1-5V</b>	-1999...9999
<b>INFR1</b>	10...70	50...158	<b>C.1V</b>	-1999...9999
<b>INFR2</b>	60...120	140...248	<b>C.0.2-1</b>	-1999...9999
<b>INFR3</b>	115...165	239...329		
<b>INFR4</b>	140...260	284...500		
<b>PT100</b>	-200...850	-328...1562		
<b>PT.LIM</b>	-50...250	-58...482		
<b>JTP10</b>	-200...600	-328...1112		
<b>60MV</b>	-1999...9999	-1999...9999		
<b>20MA</b>	-1999...9999	-1999...9999		

## 4.7.9. HI.SCL - Upper limit of scale

Acronym	Scrolling message		Submenu	Attributes
HI.SCL	INPUT HIGH LIMIT		I.MAIN	R W
<p>The parameter shows and sets the upper limit of the measurement scale used for the main input, based on input (or sensor) type, unit of measurement, and number of decimals selected. The lower value of HI.SCL is limited by the value of LO.SCL.</p> <p><b>Unit of measurement:</b> The one set with the Unit parameter</p> <p><b>Options:</b> A value in the interval corresponding to the input or sensor type (see tables for LO.SCL parameter).</p>				

## 4. CONFIGURATION

### 4.7.10. OF.SCL - Scale offset correction

Acronym	Scrolling message	Submenu	Attributes
OF.SCL	INPUT OFFSET	I.MAIN	R W
<p>The parameter shows and sets the offset applied to the value read in input to make it correspond to the expected value for a certain temperature. It corrects any constant read error of the sensor. This offset is applied linearly to all reads; therefore it cannot be used to correct any sensor linearity errors.</p> <p><b>Unit of measurement:</b> The one set with the Unit parameter</p> <p><b>Options:</b> -999...999</p>			

### 4.7.11. LO.SP - Lower limit for setpoint

Acronym	Scrolling message	Submenu	Attributes
LO.SP	LOW LIMIT FOR SETPOINT	I.MAIN	R W
<p>The parameter shows and sets the lower limit for defining the setpoint, i.e., the minimum value for setting a setpoint.</p> <p><b>Unit of measurement:</b> The one set with the Unit parameter</p> <p><b>Options:</b> LO.SCL...HI.SCL</p>			

### 4.7.12. HI.SP - Upper limit for setpoint

Acronym	Scrolling message	Submenu	Attributes
HI.SP	HIGH LIMIT FOR SETPOINT	I.MAIN	R W
<p>The parameter shows and sets the upper limit for defining the setpoint, i.e., the maximum value for setting a setpoint. The lower value of HI.SP is limited by the value of LO.SP.</p> <p><b>Unit of measurement:</b> The one set with the Unit parameter</p> <p><b>Options:</b> LO.SP...HI.SCL</p>			

### 4.7.13. LO.AL - Lower limit for alarms

Acronym	Scrolling message	Submenu	Attributes
LO.AL	LOW LIMIT FOR ABSOLUTE ALARMS	I.MAIN	R W
<p>The parameter shows and sets the lower limit for defining alarms, i.e., the minimum value for setting an alarm.</p> <p><b>Unit of measurement:</b> The one used for the alarm limit.</p> <p><b>Options:</b> -1999...9999</p>			

### 4.7.14. HI.AL - Upper limit for alarms

Acronym	Scrolling message	Submenu	Attributes
HI.AL	HIGH LIMIT FOR ABSOLUTE ALARMS	I.MAIN	R W
<p>The parameter shows and sets the upper limit for defining alarms, i.e., the maximum value for setting an alarm.</p> <p><b>Unit of measurement:</b> The one used for the alarm limit.</p> <p><b>Options:</b> -1999...9999</p>			

## 4.8. I.SPR Submenu - Configuration of remote setpoint input

Acronym	Scrolling message	Password	Description
I.SPR	REMOTE SETPOINT INPUT CONFIG	Level 1	Lets you configure the remote setpoint input if it is installed on the controller.  The remote setpoint can be assigned to the process variable PV (active in REM mode) or to the POWER value (active in MAN + REM mode).

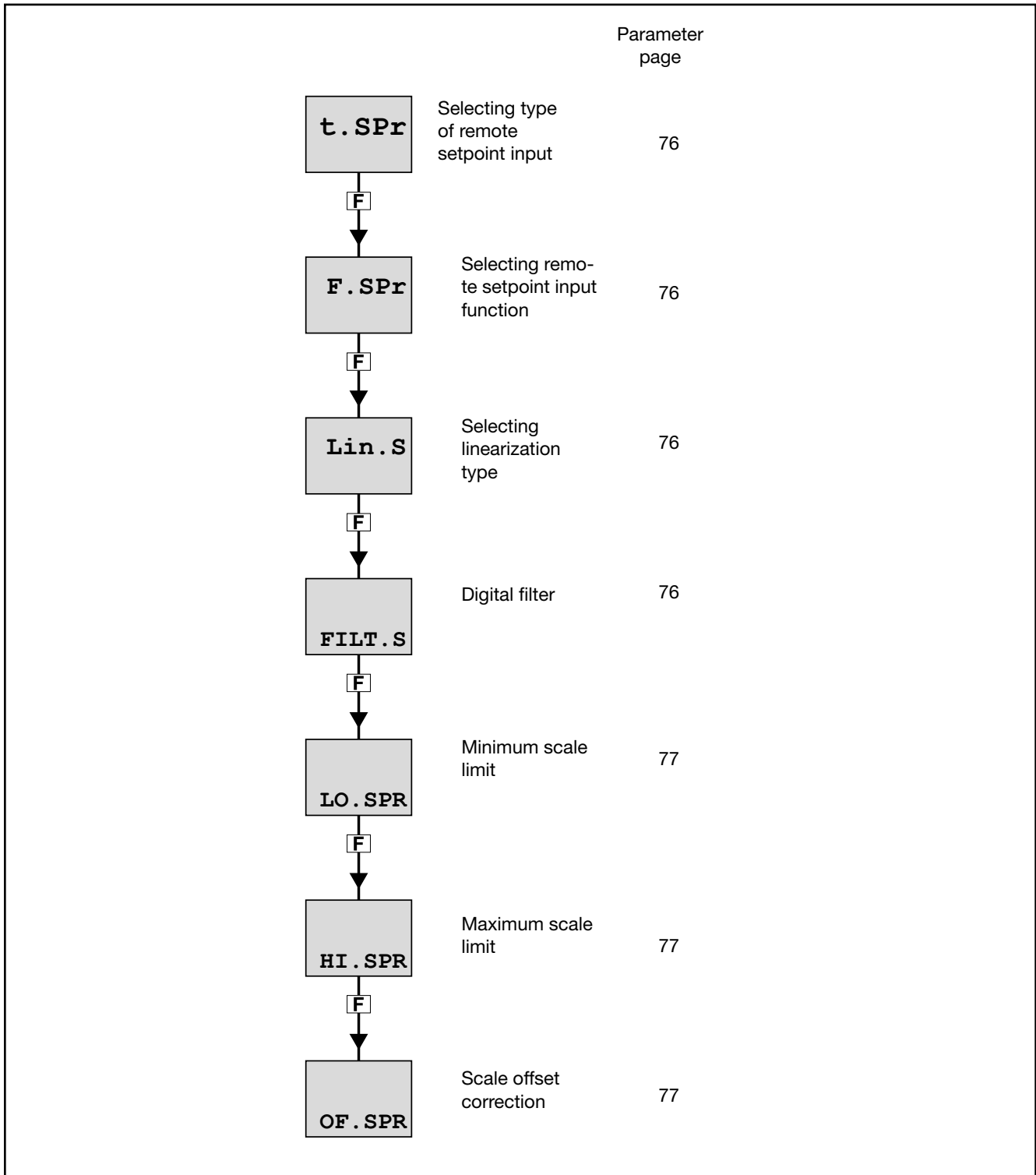

## 4. CONFIGURATION

### 4.8.1. t.SPr - Selecting type of remote setpoint input

Acronym	Scrolling message	Submenu	Attributes
t.SPr	DEFINITION OF REMOTE SETPOINT	I.SPR	R W
<p>The parameter shows and sets the type of remote setpoint input.</p> <p><b>Unit of measurement:</b> -</p> <p><b>Options:</b></p> <ul style="list-style-type: none"> <li><b>20MA</b> = Current input in 0...20 mA</li> <li><b>4-20M</b> = Current input in 4...20 mA</li> <li><b>10V</b> = Voltage input in 0...10 V</li> <li><b>2-10V</b> = Voltage input in 2...10 V</li> <li><b>1V</b> = Voltage input in 0...1 V</li> <li><b>C.20MA</b> = Current input 0...20 mA with user calibration</li> <li><b>C.4-20</b> = Current input 4...20 mA with user calibration</li> <li><b>C.10V</b> = Current input 0...10 V with user calibration</li> <li><b>C.2-10</b> = Current input 2...10 V with user calibration</li> <li><b>C.1V</b> = Current input 0...1 V with user calibration</li> </ul>			

### 4.8.2. F.SPr - Selecting remote setpoint input function

Acronym	Scrolling message	Submenu	Attributes
F.SPr	FUNCTION OF REMOTE SETPOINT	I.SPR	R W
<p>The parameter shows and sets the function assigned to the remote setpoint input.</p> <p><b>Unit of measurement:</b> -</p> <p><b>Options:</b></p> <ul style="list-style-type: none"> <li><b>NONE</b> = Display only</li> <li><b>SETP</b> = Remote setpoint of Process Value (PV)</li> <li><b>POWER</b> = Remote setpoint of Power</li> <li><b>RST.PW</b> = Reset power</li> </ul>			

### 4.8.3. Lin.S - Selecting linearization type

Acronym	Scrolling message	Submenu	Attributes
Lin.S	CUSTOM LINEARIZATION	I.SPR	R W
<p>The parameter shows and sets the type of linearization used.</p> <p><b>Unit of measurement:</b> -</p> <p><b>Options:</b></p> <ul style="list-style-type: none"> <li><b>NONE</b> = No linearization is applied</li> <li><b>32.STP</b> = 32-step linearization defined on LINRZ menu is applied</li> <li><b>4.POIN</b> = 4-point linearization defined on LINRZ menu is applied</li> </ul>			

### 4.8.4. FILT.S - Filtro digitale

Acronym	Scrolling message	Submenu	Attributes
FILT.S	DIGITAL FILTER	I.SPR	R W
<p>The parameter shows and sets the value of the digital filter time constant.</p> <p><b>Unit of measurement:</b> -</p> <p><b>Options:</b> 0.00...20.00</p>			

## 4.8.5. LO.SPR - Minimum scale limit

Acronym	Scrolling message	Submenu	Attributes
LO.SPR	INPUT LOW LIMIT	I.SPR	R W
<p>The parameter shows and sets the minimum scale limit.</p> <p><b>Unit of measurement:</b> Scale points or %, according to the remote setpoint input function selected</p> <p><b>Options:</b>                -1999...9999 = In scale points referred to main input                               -199.9...999.9 = In %, if the Power or RST.PW function was selected</p>			

## 4.8.6. HI.SPR - Maximum scale limit

Acronym	Scrolling message	Submenu	Attributes
HI.SPR	INPUT HIGH LIMIT	I.SPR	R W
<p>The parameter shows and sets the maximum scale limit.</p> <p><b>Unit of measurement:</b> Scale points or %, according to the remote setpoint input function selected</p> <p><b>Options:</b>                LO.SPR...9999 = In scale points referred to main input                               LO.SPR...999.9 = In %, if the Power or RST.PW function was selected</p>			

## 4.8.7. OF.SPR - Scale offset correction

Acronym	Scrolling message	Submenu	Attributes
OF.SPR	INPUT OFFSET	I.SPR	R W
<p>The parameter shows and sets the scale offset, i.e., the constant offset applied to all values measured by the input.</p> <p><b>Unit of measurement:</b> Scale points</p> <p><b>Options:</b>                -999...999</p>			

## 4. CONFIGURATION

### 4.9. I.CT1 Submenu - Configuration of current transformer CT1

Acronym	Scrolling message	Password	Description
I.CT1	CURRENT TRASFORMER 1 INPUT CONFIG	Level 1	Lets you configure the input for current transformer CT1.

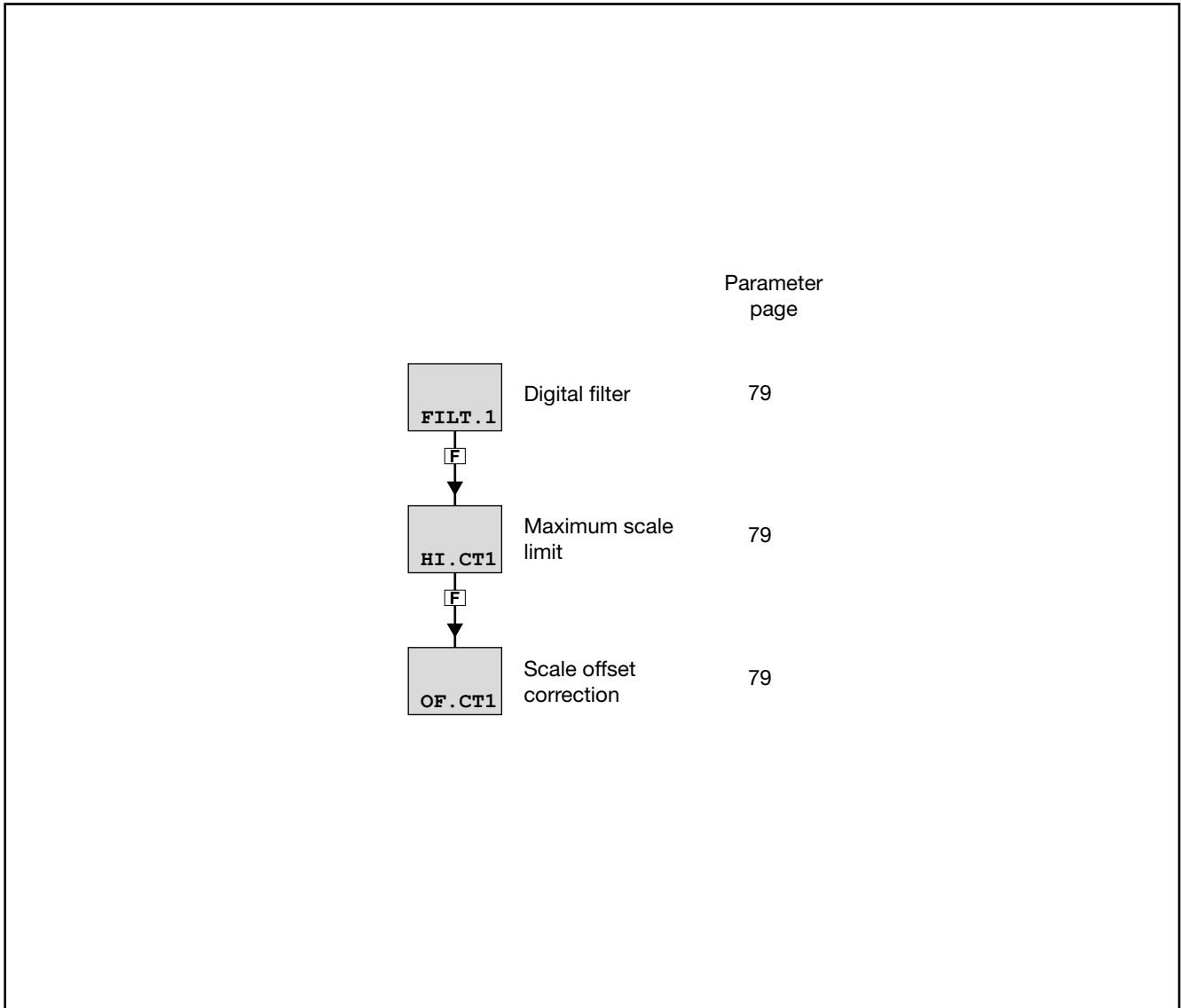

4.9.1. **FILT.1 - Digital filter**

Acronym	Scrolling message	Submenu	Attributes
FILT.1	DIGITAL FILTER	I.CT1	R W
The parameter shows and sets the value of the digital filter time constant applied to the input for current transformer CT1.			
<i>Unit of measurement:</i> Seconds			
<i>Options:</i> 0.00...20.00			

4.9.2. **HI.CT1 - Maximum scale limit**

Acronym	Scrolling message	Submenu	Attributes
HI.CT1	INPUT HIGH LIMIT	I.CT1	R W
The parameter shows and sets the maximum scale limit of the input for current transformer CT1.			
<i>Unit of measurement:</i> A			
<i>Options:</i> 0.0...100.0			

4.9.3. **OF.CT1 - Scale offset correction**

Acronym	Scrolling message	Submenu	Attributes
OF.CT1	INPUT OFFSET	I.CT1	R W
The parameter shows and sets the scale offset, i.e., the constant offset applied to all values measured by current transformer CT1.			
<i>Unit of measurement:</i> A			
<i>Options:</i> -99.9...99.9			

## 4. CONFIGURATION

### 4.10. I.CT2 Submenu - Configuration of current transformer CT2

Acronym	Scrolling message	Password	Description
I.CT2	CURRENT TRASFORMER 2 INPUT CONFIG	Level 1	Lets you configure the input for current transformer CT2.

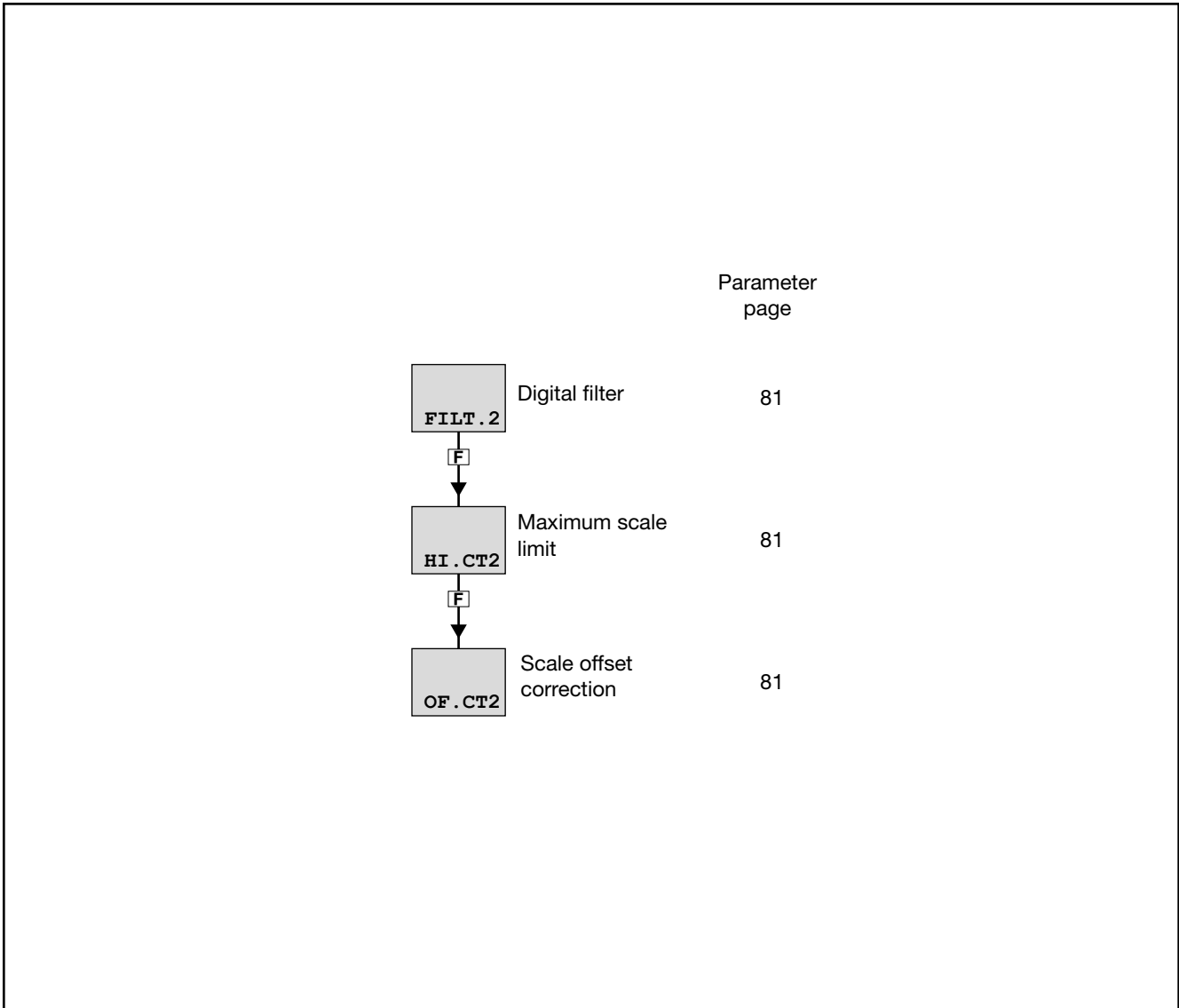

## 4.10.1. FILT.2 - Digital filter

Acronym	Scrolling message	Submenu	Attributes
FILT.2	DIGITAL FILTER	I.CT2	R W
<p>The parameter shows and sets the value of the digital filter time constant applied to the input for current transformer CT2.</p> <p><b>Unit of measurement:</b> Seconds</p> <p><b>Options:</b> 0.00...20.00</p>			

## 4.10.2. HI.CT2 - Maximum scale limit

Acronym	Scrolling message	Submenu	Attributes
HI.CT2	INPUT HIGH LIMIT	I.CT2	R W
<p>The parameter shows and sets the maximum scale limit of the input for current transformer CT2.</p> <p><b>Unit of measurement:</b> A</p> <p><b>Options:</b> 0.0...100.0</p>			

## 4.10.3. OF.CT2 - Scale offset correction

Acronym	Scrolling message	Submenu	Attributes
OF.CT2	INPUT OFFSET	I.CT2	R W
<p>The parameter shows and sets the scale offset, i.e., the constant offset applied to all values measured by current transformer CT2.</p> <p><b>Unit of measurement:</b> A</p> <p><b>Options:</b> -99.9...99.9</p>			

## 4. CONFIGURATION

### 4.11. ALARM Submenu - Configuration of alarms

Acronym	Scrolling message	Password	Description
ALARM	ALARM CONFIG	Level 1	Lets you configure the generic alarms.

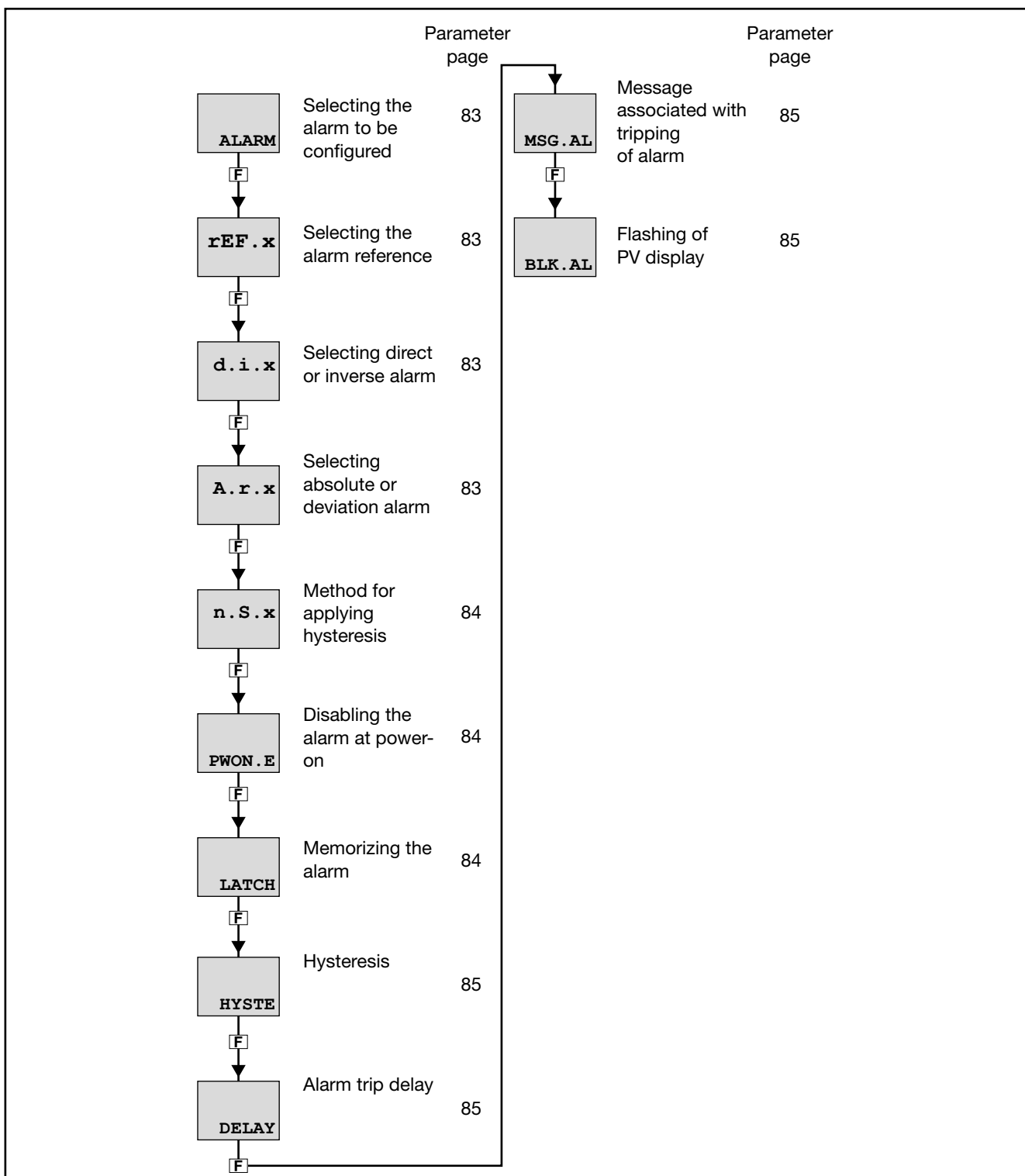

## 4.11.1. ALARM - Selecting the alarm to be configured

Acronym	Scrolling message	Submenu	Attributes
ALARM	ALARM NUMBER	ALARM	R W
<p>The parameter shows and sets the alarm to be configured, identified by its number.</p> <p><b>Unit of measurement:</b> Number</p> <p><b>Options:</b>            <b>1...ALRM.N</b> = Identifying number of alarm, where ALRM.N is the total number of alarms, setting by submenu MODE.</p>			

## 4.11.2. rEF.x - Selecting the alarm reference

Acronym	Scrolling message	Submenu	Attributes
rEF.x	SELECTING REFERENCE SIGNAL	ALARM	R W
<p>The parameter shows and sets the reference of alarm number “x” selected with the previous parameter ALARM, where the reference can be an input or value to be monitored.</p> <p><b>Unit of measurement:</b> -</p> <p><b>Options:</b></p> <ul style="list-style-type: none"> <li><b>PV</b> = Process variable</li> <li><b>IN.SPR</b> = Remote setpoint input</li> <li><b>SP.ACT</b> = Actual setpoint</li> <li><b>CURR1</b> = Current of current transformer CT1</li> <li><b>CURR2</b> = Current of current transformer CT2</li> <li><b>OUT.KW</b> = Power transferred to the load</li> <li><b>ENERG</b> = Energy transferred to load</li> <li><b>TOT.EN</b> = Totalizer Energy transferred to the load</li> <li><b>T.INT</b> = Internal temperature</li> </ul>			

## 4.11.3. d.i.x - Selecting direct or inverse alarm

Acronym	Scrolling message	Submenu	Attributes
d.i.x	DIRECT/INVERSE DEFINITION	ALARM	R W
<p>The parameter shows and sets the behavior of alarm number “x” with respect to the alarm limit and hysteresis. Direct or inverse defines when the alarm has to trip. For a detailed explanation of this behavior, see paragraph “5.6.1. Generic alarms AL1...AL4” on page “5.6.1. Generic alarms AL1...AL4” on page 150.</p> <p><b>Unit of measurement:</b> -</p> <p><b>Options:</b></p> <ul style="list-style-type: none"> <li><b>DIREC</b> = Direct Alarm</li> <li><b>INVR</b> = Inverse Alarm</li> </ul>			

## 4.11.4. A.r.x - Selecting absolute or deviation alarm

Acronym	Scrolling message	Submenu	Attributes
A.r.x	ABSOLUTE/DEVIATION DEFINITION	ALARM	R W
<p>The parameter shows and defines the reference value of alarm number “x” for the alarm limit. For a detailed explanation of the difference between absolute and deviation, see paragraph “5.6.1. Generic alarms AL1...AL4” on page “5.6.1. Generic alarms AL1...AL4” on page 150.</p> <p><b>Unit of measurement:</b> -</p> <p><b>Options:</b></p> <ul style="list-style-type: none"> <li><b>ABSLT</b> = Absolute alarm</li> <li><b>RELAT</b> = Deviation alarm</li> </ul>			

## 4. CONFIGURATION

### 4.11.5. n.S.x - Method for applying hysteresis

Acronym	Scrolling message	Submenu	Attributes
n.S.x	NORMAL/SYMMETRIC DEFINITION	ALARM	R W
<p>The parameter shows and sets the method for applying hysteresis for alarm number “x” with respect to the alarm limit value.</p> <p>With normal, hysteresis is added to / subtracted from the alarm limit(s) based on the general alarm configuration. With symmetrical, hysteresis is added to / subtracted from the alarm limit itself. For a detailed explanation of the difference between normal and symmetrical, see paragraph “5.6.1. Generic alarms AL1...AL4” on page “5.6.1. Generic alarms AL1...AL4” on page 150.</p> <p><b>Unit of measurement:</b> -</p> <p><b>Options:</b>           <b>NORML</b> = Normal alarm                            <b>SYMMT</b> = Symmetrical alarm (window)</p>			

### 4.11.6. PWON.E - Disabling the alarm at power-on

Acronym	Scrolling message	Submenu	Attributes
PWON.E	DISABLE AT SWITCH ON	ALARM	R W
<p>The parameter shows and sets the behavior of the alarm (being configured) when the controller is powered on.</p> <p>If the parameter is “OFF,” the alarm will trip when the controller is powered on if the process variable exceeds the alarm setpoint limits.</p> <p>If the parameter is “On,” the alarm will not trip until the alarm limit value is reached at least once after the controller is powered on.</p> <p>ATTENTION! The setpoint can be reached in increment or in decrement, or it may never be reached. Therefore, with “On” the alarm might never trip even if the value of the process variable exceeds the alarm setpoint limits.</p> <p><b>Example – Minimum, inverse and absolute alarm</b></p> <p>When the system is off, the process variable equals room temperature (20 °C). The alarm setpoint is set at 150°C ± 10°C. The controller powers on with the system.</p> <p>So with “OFF” the alarm trips as soon as the controller is powered on because the temperature of the process variable exceeds the alarm setpoint limits.</p> <p>Instead, with “On” the alarm trips only after the temperature of 150°C is reached at least once for the process variable.</p> <p><b>Unit of measurement:</b> -</p> <p><b>Options:</b>           <b>OFF</b>    = Alarm enabled at power-on                            <b>On</b>     = Alarm disabled at power-on (until setpoint is reached)</p>			

### 4.11.7. LATCH - Memorizing the alarm

Acronym	Scrolling message	Submenu	Attributes
LATCH	MEMORY DEFINITION	ALARM	R W
<p>The parameter shows and sets enabling of memorization of the alarm being configured.</p> <p>Memorization maintains the active alarm state even after the alarm conditions are eliminated.</p> <p>The alarm state can be deleted by from the digital input, serial input, or key.</p> <p><b>Unit of measurement:</b> -</p> <p><b>Options:</b>           <b>OFF</b>    = Alarm not latched                            <b>On</b>     = Alarm latched</p>			

## 4.11.8. HYTE - Hysteresis

Acronym	Scrolling message	Submenu	Attributes
HYTE	HYSTERESIS	ALARM	R W
<p>The parameter shows and sets the hysteresis applied to the alarm setpoint value for the alarm being configured.</p> <p><b>Unit of measurement:</b> Scale points</p> <p><b>Options:</b>                <b>0...999</b> = For absolute (A.r.x = ABSLT) and symmetrical alarm (n.S.x = SYMMT)                                <b>-999...999</b> = For other types of alarms</p>			

## 4.11.9. DELAY - Alarm trip delay

Acronym	Scrolling message	Submenu	Attributes
DELAY	DELAY OF ACTIVATION	ALARM	R W
<p>The parameter shows and sets the alarm trip delay for the alarm being configured, i.e., the time that the value of the process variable has to exceed the alarm setpoint for the alarm to trip.</p> <p>This parameter prevents repeated alarms due to instantaneous and insignificant exceeding of that value.</p> <p>If the parameter is set to "0.00" the alarm will be instantaneous, regardless of the time in which the process variable exceeds the alarm setpoint.</p> <p>For a detailed explanation of this behavior, see paragraph "5.6.1. Generic alarms AL1...AL4" on page "5.6.1. Generic alarms AL1...AL4" on page 150.</p> <p><b>Unit of measurement:</b> Minutes.seconds</p> <p><b>Options:</b>                <b>0.00...99.59</b></p>			

## 4.11.10. MSG.AL - Message associated with tripping of alarm

Acronym	Scrolling message	Submenu	Attributes
MSG.AL	SCROLLING MESSAGE AT ALARM ACT	ALARM	R W
<p>The parameter shows and sets the number of the message associated with tripping of the alarm being configured, i.e., the scrolling message shown on the display.</p> <p>For more information on scrolling messages, see paragraph "3.1.2.2. Scrolling messages" on page 34.</p> <p>If the parameter is set to "0" no message will be displayed when the alarm trips.</p> <p>The same message number can be assigned to different alarms</p> <p><b>Unit of measurement:</b> Message number</p> <p><b>Options:</b>                <b>0...25</b></p>			

## 4.11.11. BLK.AL - Flashing of PV display

Acronym	Scrolling message	Submenu	Attributes
BLK.AL	BLINK DISPLAY PV DEF	ALARM	R W
<p>The parameter shows and sets the flashing of the PV display in case of alarm, for the alarm being configured.</p> <p>If the parameter is "On," the value shown on the PV display starts to flash in case of alarm.</p> <p><b>Unit of measurement:</b> -</p> <p><b>Options:</b>                <b>OFF</b> = PV display does not flash in case of alarm                                <b>On</b> = PV display flashes in case of alarm</p>			

## 4. CONFIGURATION

### 4.12. AL.HB Submenu – Configuring the Heater Break alarm

Acronym	Scrolling message	Password	Description
AL.HB	HEATER BREAK ALARM CONFIG	Level 1	Lets you configure the Heater Break alarm, i.e., the alarm that trips when the heating element is outside normal operating parameters.  The submenu is present if the CT1 or CT1+CT2 input option was previously selected.

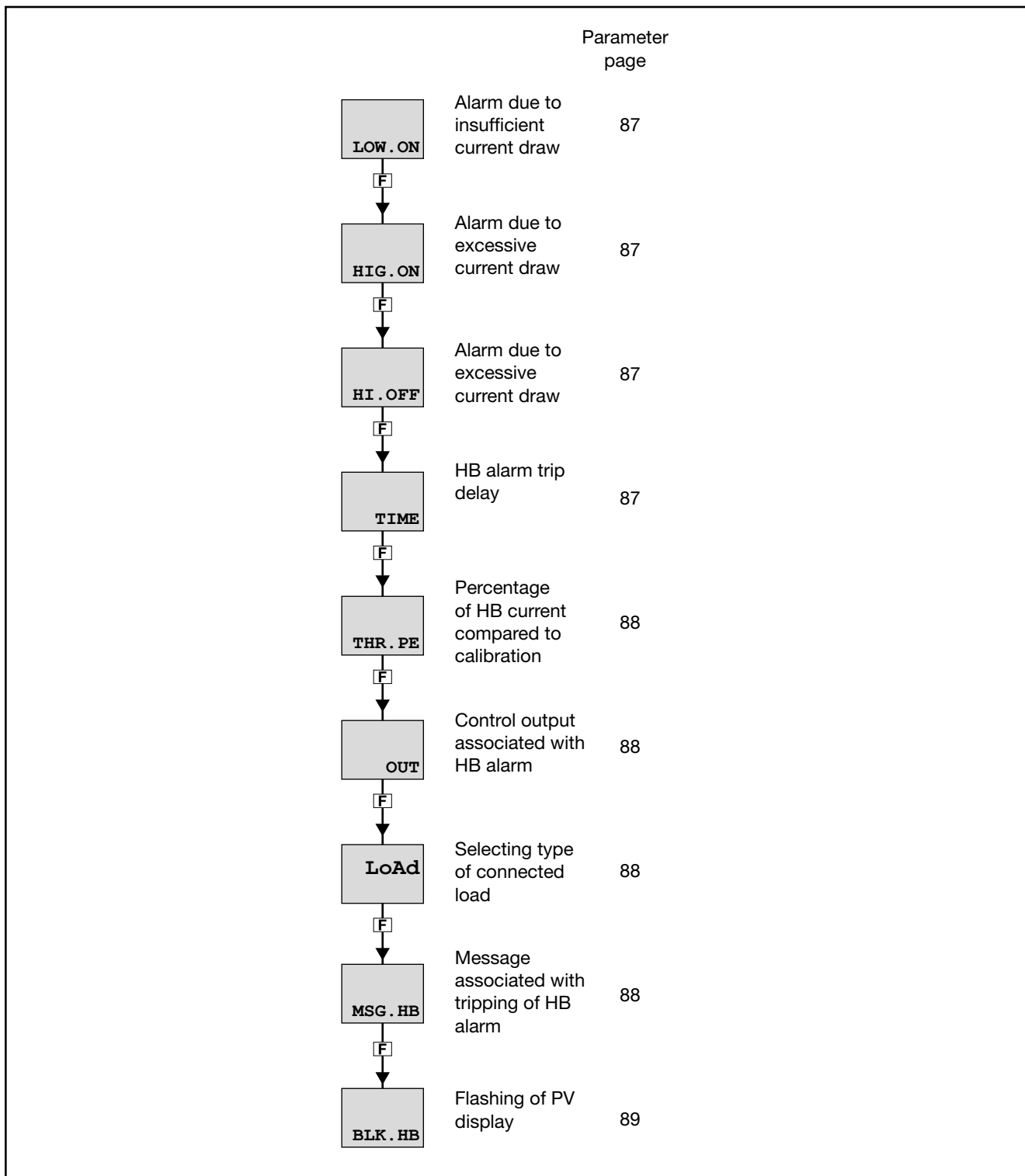

## 4.12.1. LOW.ON - Alarm due to insufficient current draw

Acronym	Scrolling message	Submenu	Attributes
LOW.ON	LOW LOAD CURR THRESH ON TIME	AL.HB	R W
<p>The parameter shows and sets the current draw value below which the Heater Break alarm trips when the control output is ON.</p> <p>If the draw is too low it is assumed that the heating element is broken. The signal may also be caused by a power failure on the heating element supply line.</p> <p><b>Unit of measurement:</b> A</p> <p><b>Options:</b> 0.0...999.9</p>			

## 4.12.2. HIG.ON - Alarm due to excessive current draw

Acronym	Scrolling message	Submenu	Attributes
HIG.ON	HIGH LOAD CURR THRESH ON TIME	AL.HB	R W
<p>The parameter shows and sets the current draw value above which the Heater Break alarm trips when the control output is ON.</p> <p>If the draw is too high it is assumed that the heating element or its supply line is in short circuit.</p> <p><b>Unit of measurement:</b> A</p> <p><b>Options:</b> 0.0...999.9</p>			

## 4.12.3. HI.OFF - Alarm due to excessive current draw

Acronym	Scrolling message	Submenu	Attributes
HI.OFF	HIGH LOAD CURR THRESH OFF TIME	AL.HB	R W
<p>The parameter shows and sets the current draw value above which the Heater Break alarm trips when the control output is OFF.</p> <p>If the draw is too high it is assumed that the heating element or its supply line (eg a module SSR) is in short circuit.</p> <p><b>Unit of measurement:</b> A</p> <p><b>Options:</b> 0.0...999.9</p>			

## 4.12.4. TIME - HB alarm trip delay

Acronym	Scrolling message	Submenu	Attributes
TIME	WAITING TIME FOR ALHB TRIP	AL.HB	R W
<p>The parameter shows and sets the minimum time in which the overrun defined by LOW.ON, HIG.ON and HI.OFF must persist before the HB alarm trips.</p> <p>This parameter prevents false alarms caused by momentary positive or negative peaks in current draw.</p> <p>If the value is set to "0" the alarm is immediate.</p> <p><b>Unit of measurement:</b> Seconds</p> <p><b>Options:</b> 0...999</p>			

## 4. CONFIGURATION

### 4.12.5. THR.PE - Percentage of HB current compared to calibration

Acronym	Scrolling message	Submenu	Attributes
THR.PE	PERCENTAGE HB ALARM SP IN HB CALIB	AL.HB	R W
<p>The parameter shows and sets the current draw value for the Heater Break alarm. This value is expressed as a percentage of the current draw value set during calibration. For more information on this calibration, see paragraph LOW.ON. See also paragraph “4.25. Submenu US.CAL – User calibrations” on page “4.25. US.CAL Submenu – User calibrations” on page 139.</p> <p><b>Unit of measurement:</b> %</p> <p><b>Options:</b> 0.0...100.0 (default value = 80.0)</p>			

### 4.12.6. OUT - Control output associated with HB alarm

Acronym	Scrolling message	Submenu	Attributes
OUT	CONTROL OUTPUT HB AL	AL.HB	R W
<p>The parameter shows and sets the number of the control output associated with the alarm. This is the output whose ON/OFF state is checked, as indicated in the description of the LOW.ON, HIG.ON and HI.OFF parameters.</p> <p><b>Unit of measurement:</b> Number</p> <p><b>Options:</b> 1...4</p>			

### 4.12.7. LoAd - Selecting type of connected load

Acronym	Scrolling message	Submenu	Attributes
LoAd	TYPE OF LOAD CONFIGURATION	AL.HB	R W
<p>The parameter shows and sets the type of load connected to the control output. For more information on load type, see paragraph “5.6.2. HB Alarm” on page “5.6.2. HB alarm” on page 151.</p> <p><b>Unit of measurement:</b> -</p> <p><b>Options:</b> <b>MONO</b> = Monophase power supply, with current transformer CT1 only (if current transformer CT2 is present it is ignored)  <b>STAR</b> = 3-phase star power supply without neutre, with CT1 and CT2  <b>DELTA</b> = 3-phase delta power supply with CT1 and CT2</p>			

### 4.12.8. MSG.HB - Message associated with tripping of HB alarm

Acronym	Scrolling message	Submenu	Attributes
MSG.HB	SCROLLING MESSAGE AT HB ACT	AL.HB	R W
<p>The parameter shows and sets the number of the message associated with tripping of the HB alarm, i.e., the scrolling message shown on the display. For more information on scrolling messages, see paragraph “3.1.2.2. Scrolling messages” on page 34. If the parameter is set to “0” no message will be displayed when the alarm trips. The same message number can be assigned to different alarms.</p> <p><b>Unit of measurement:</b> Message number</p> <p><b>Options:</b> 0...25</p>			

## 4.12.9. BLK.HB - Flashing of PV display

Acronym	Scrolling message	Submenu	Attributes
BLK.HB	BLINK DISPLAY PV DEF HB AL	AL.HB	R W
<p>The parameter shows and sets the flashing of the PV display in case of HB alarm.            If the parameter is "On," the value shown on the PV display starts to flash with backlight at full brightness in case of HB alarm.</p> <p><b>Unit of measurement:</b> -</p> <p><b>Options:</b></p> <p><b>OFF</b> = PV display does not flash in case of alarm</p> <p><b>On</b> = PV display flashes in case of alarm</p>			

## 4. CONFIGURATION

### 4.13. PID Submenu – Configuring control parameters

Acronym	Scrolling message	Password	Description
PID	PID CONFIG	Level 1	Lets you configure the control parameters

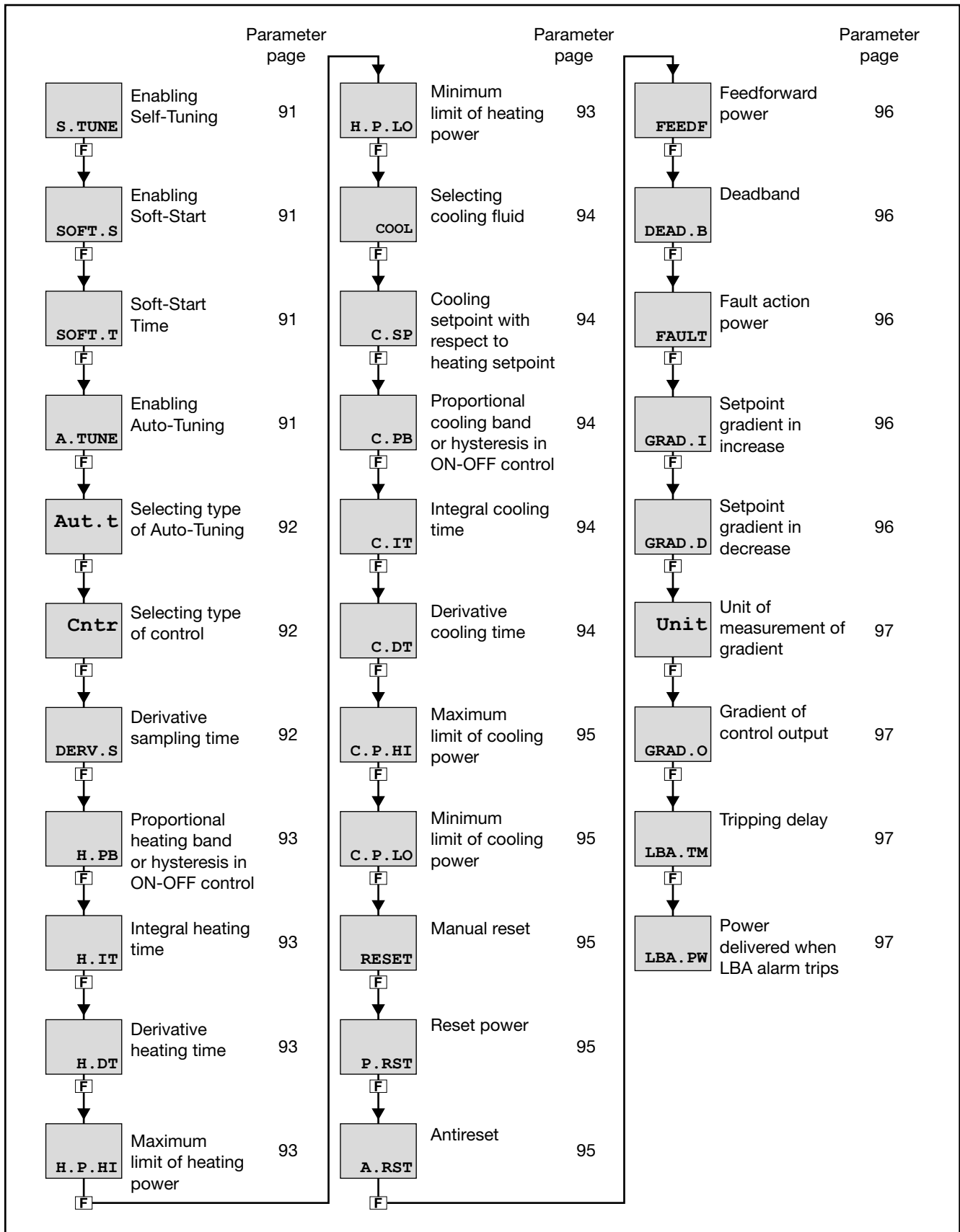

## 4.13.1. S.TUNE - Enabling Self-Tuning

Acronym	Scrolling message	Submenu	Attributes
S.TUNE	SELF TUNING ENABLE	PID	R W
<p>The parameter shows and sets enabling of Self-Tuning. For more information on the Self-Tuning function, see paragraph "5.10.3. Self-Tuning" on page "5.10.3. Self-Tuning" on page 153.</p> <p><b>Unit of measurement:</b> -</p> <p><b>Options:</b>           <b>OFF</b>    = Self-Tuning disabled                           <b>On</b>       = Self-Tuning enabled at next power-on only                           <b>On.AL</b>   = Self-Tuning enabled at all power-ons</p>			

## 4.13.2. SOFT.S - Enabling Soft-Start

Acronym	Scrolling message	Submenu	Attributes
SOFT.S	SOFT START ENABLE	PID	R W
<p>The parameter shows and sets enabling of Soft-Start. For more information on the Self-Start function, see paragraph "5.9. Soft-Start" on page "5.9. Soft-Start" on page 152. This parameter appears only if S.TUNE = OFF.</p> <p><b>Unit of measurement:</b> -</p> <p><b>Options:</b>           <b>OFF</b>    = Soft-Start disabled                           <b>On</b>       = Soft-Start enabled at next power-on</p>			

## 4.13.3. SOFT.T - Soft-Start Time

Acronym	Scrolling message	Submenu	Attributes
SOFT.T	SOFT START TIME	PID	R W
<p>The parameter shows and sets Soft-Start time, i.e., the time that the control output needs to reach the value required by the PID. This parameter appears only if SOFT.S = On.</p> <p><b>Unit of measurement:</b> Minutes</p> <p><b>Options:</b>           <b>0.0...500.0</b></p>			

## 4.13.4. A.TUNE - Enabling Auto-Tuning

Acronym	Scrolling message	Submenu	Attributes
A.TUNE	AUTO TUNING ENABLE	PID	R W
<p>The parameter shows and sets enabling of Auto-Tuning. For more information on the Auto-Tuning function, see paragraph "5.10.4. Auto-Tuning" on page "5.10.4. Auto-Tuning" on page 154.</p> <p><b>Unit of measurement:</b> -</p> <p><b>Options:</b>           <b>OFF</b>    = Auto-Tuning disabled                           <b>On</b>       = Auto-Tuning enabled</p>			

## 4. CONFIGURATION

### 4.13.5. Aut.t - Selecting type of Auto-Tuning

Acronym	Scrolling message	Submenu	Attributes
Aut.t	AUTO TUNING SELECTION	PID	R W
<p>The parameter shows and sets the type of Auto-Tuning used.</p> <p><b>Unit of measurement:</b> -</p> <p><b>Options:</b></p> <p><b>CONTI</b> = Continuous Auto-Tuning</p> <p><b>O.SHOT</b> = One-shot Auto-Tuning</p> <p><b>DEV0.5</b> = One-shot Auto-Tuning with activation when  SP-PV  &gt; 0,5% of full scale of main input</p> <p><b>DEV1</b> = One-shot Auto-Tuning with activation when  SP-PV  &gt; 1% of full scale of main input</p> <p><b>DEV2</b> = One-shot Auto-Tuning with activation when  SP-PV  &gt; 2% of full scale of main input</p> <p><b>DEV4</b> = One-shot Auto-Tuning with activation when  SP-PV  &gt; 4% of full scale of main input</p>			

### 4.13.6. Cntr - Selecting type of control

Acronym	Scrolling message	Submenu	Attributes
Cntr	TYPE OF CONTROL	PID	R W
<p>The parameter shows and sets the type control performed by the controller. For more information on the control function, see paragraph "5.10. Controls" on page 140.</p> <p><b>Unit of measurement:</b> -</p> <p><b>Options:</b></p> <p><b>H.PROP</b> = Proportional heating</p> <p><b>H.PI</b> = Proportional/integral heating</p> <p><b>H.PID</b> = Proportional integral/derivative heating</p> <p><b>C.PROP</b> = Proportional cooling</p> <p><b>C.PI</b> = Proportional/integral cooling</p> <p><b>C.PID</b> = Proportional integral/derivative cooling</p> <p><b>HC.P</b> = Proportional heating/cooling</p> <p><b>HC.PI</b> = Proportional/integral heating/cooling</p> <p><b>HC.PID</b> = Proportional integral/derivative heating/cooling</p> <p><b>H.ONOF</b> = Heating ON-OFF</p> <p><b>C.ONOF</b> = Cooling ON-OFF</p> <p><b>HC.ONO</b> = Heating/cooling ON-OFF</p> <p><b>HP.CON</b> = PID heating / cooling ON-OFF</p> <p><b>HON.CP</b> = Heating ON-OFF / PID cooling</p> <p><b>PID.RG</b> = Heating / PID cooling with relative gain</p>			

### 4.13.7. DERVS - Derivative sampling time

Acronym	Scrolling message	Submenu	Attributes
DERVS	DERIVATIVE SAMPLE TIME	PID	R W
<p>The parameter shows and sets the derivative sampling time. The parameter is shown if the derivative action was enabled with parameter Cntr.</p> <p><b>Unit of measurement:</b> Seconds</p> <p><b>Options:</b></p> <p>0.240</p> <p>1</p> <p>4</p> <p>8</p>			

**4.13.8. H.PB - Proportional heating band or hysteresis in ON-OFF control**

Acronym	Scrolling message	Submenu	Attributes
H.PB	HEATING PROPORTIONAL BAND OR ON/OFF HYST	PID	R W
<p>The parameter shows and sets the proportional heating band or hysteresis in the ON-OFF control, calculated as a percentage of full scale of the main input.</p> <p><b>Unit of measurement:</b> %</p> <p><b>Options:</b> 0.0...999.9</p>			

**4.13.9. H.IT - Integral heating time**

Acronym	Scrolling message	Submenu	Attributes
H.IT	HEATING INTEGRAL TIME	PID	R W
<p>The parameter shows and sets the integral heating time.</p> <p><b>Unit of measurement:</b> Minutes</p> <p><b>Options:</b> 0.00...99.99</p>			

**4.13.10. H.DT - Derivative heating time**

Acronym	Scrolling message	Submenu	Attributes
H.DT	HEATING DERIVATIVE TIME	PID	R W
<p>The parameter shows and sets the derivative heating time.</p> <p><b>Unit of measurement:</b> Minutes</p> <p><b>Options:</b> 0.00...99.99</p>			

**4.13.11. H.P.HI - Maximum limit of heating power**

Acronym	Scrolling message	Submenu	Attributes
H.P.HI	HEATING POWER HIGH LIMIT	PID	R W
<p>The parameter shows and sets the maximum limit of heating power.</p> <p><b>Unit of measurement:</b> %</p> <p><b>Options:</b> 0.0...100.0</p>			

**4.13.12. H.P.LO - Minimum limit of heating power**

Acronym	Scrolling message	Submenu	Attributes
H.P.LO	HEATING POWER LOW LIMIT	PID	R W
<p>The parameter shows and sets the minimum limit of heating power. Not available for dual action. The power of PID heating/cooling control (called dual action) is limited by the values of H.P.HI and C.P.HI.</p> <p><b>Unit of measurement:</b> %</p> <p><b>Options:</b> 0.0...100.0</p>			

## 4. CONFIGURATION

### 4.13.13. COOL - Selecting cooling fluid

Acronym	Scrolling message	Submenu	Attributes
COOL	COOLING MEDIA	PID	R W
<p>The parameter shows and sets the fluid used for cooling. The parameter appears if the parameter Cntr = PID.RGn was selected.</p> <p><b>Unit of measurement:</b> -</p> <p><b>Options:</b>           <b>FAN</b> = Air (relative gain H.PB/C.PB = 1)                           <b>OIL</b> = Oil (relative gain H.PB/C.PB = 0,8)                           <b>H2O</b> = Water (relative gain H.PB/C.PB = 0,4)</p>			

### 4.13.14. C.SP - Cooling setpoint with respect to heating setpoint

Acronym	Scrolling message	Submenu	Attributes
C.SP	COOLING SETPOINT RELEVANT TO THE HEATING SETPOINT	PID	R W
<p>The parameter shows and sets the cooling setpoint as a percentage change of the heating setpoint. Negative values superimpose cooling on heating.</p> <p><b>Unit of measurement:</b> %, of full scale of main input</p> <p><b>Options:</b>            <b>-25.0...25.0</b></p>			

### 4.13.15. C.PB - Proportional cooling band or hysteresis in ON-OFF control

Acronym	Scrolling message	Submenu	Attributes
C.PB	COOLING PROPORTIONAL BAND OR ON/OFF HYST	PID	R W
<p>The parameter shows and sets the proportional cooling band or hysteresis in the ON-OFF control, calculated as a percentage of full scale of the main input.</p> <p><b>Unit of measurement:</b> %</p> <p><b>Options:</b>            <b>0.0...999.9</b></p>			

### 4.13.16. C.IT - Integral cooling time

Acronym	Scrolling message	Submenu	Attributes
C.IT	COOLING INTEGRAL TIME	PID	R W
<p>The parameter shows and sets the integral cooling time.</p> <p><b>Unit of measurement:</b> Minutes</p> <p><b>Options:</b>            <b>0.00...99.99</b></p>			

### 4.13.17. C.DT - Derivative cooling time

Acronym	Scrolling message	Submenu	Attributes
C.DT	COOLING DERIVATIVE TIME	PID	R W
<p>The parameter shows and sets the derivative cooling time.</p> <p><b>Unit of measurement:</b> Minutes</p> <p><b>Options:</b>            <b>0.00...99.99</b></p>			

## 4.13.18. C.P.HI - Maximum limit of cooling power

Acronym	Scrolling message	Submenu	Attributes
C.P.HI	COOLING POWER HIGH LIMIT	PID	R W
<p>The parameter shows and sets the maximum limit of cooling power.</p> <p><b>Unit of measurement:</b> %</p> <p><b>Options:</b> 0.0...100.0</p>			

## 4.13.19. C.P.LO - Minimum limit of cooling power

Acronym	Scrolling message	Submenu	Attributes
C.P.LO	COOLING POWER LOW LIMIT	PID	R W
<p>The parameter shows and sets the lower limit of cooling power. Not available for dual action. The power of PID heating/cooling control (called dual action) is limited by the values of H.P.HI and C.P.HI.</p> <p><b>Unit of measurement:</b> %</p> <p><b>Options:</b> 0.0...100.0</p>			

## 4.13.20. RESET - Manual reset

Acronym	Scrolling message	Submenu	Attributes
RESET	MANUAL RESET	PID	R W
<p>The parameter shows and sets the Manual reset value, i.e., the value which, when added to setpoint, becomes the reference for the control. It is useful in a PID control with non-variable setpoint to compensate the error at full scale.</p> <p><b>Unit of measurement:</b> Scale points of main input</p> <p><b>Options:</b> -999...999</p>			

## 4.13.21. P.RST - Reset Power

Acronym	Scrolling message	Submenu	Attributes
P.RST	RESET POWER	PID	R W
<p>The parameter shows and sets the Reset power value, i.e., the value added to the control power. For example, in proportional control it corresponds to the output at zero value (PV = SV).</p> <p><b>Unit of measurement:</b> %</p> <p><b>Options:</b> -100.0...100.0</p>			

## 4.13.22. A.RST - Antireset

Acronym	Scrolling message	Submenu	Attributes
A.RST	ANTIRESET	PID	R W
<p>The parameter shows and sets the Antireset value. If set to other than "0", it defines band width (below the setpoint if heating, above the setpoint if cooling) within which the integral action is applied, if provided (PI or PID control).</p> <p><b>Unit of measurement:</b> Scale points of main input</p> <p><b>Options:</b> 0...9999</p>			

## 4. CONFIGURATION

### 4.13.23. FEEDF - Feedforward power

Acronym	Scrolling message	Submenu	Attributes
FEEDF	FEEDFORWARD	PID	R W
<p>The parameter shows and sets the feedforward power value, i.e., the value that generates an additional factor at the control output based on the setpoint value.</p> $U = \frac{\text{set point}}{\text{full scale} - \text{start scale}} \times \frac{\text{FEEDF}}{100}$ <p><b>Unit of measurement:</b> %</p> <p><b>Options:</b> -100.0...100.0</p>			

### 4.13.24. DEAD.B - Deadband

Acronym	Scrolling message	Submenu	Attributes
DEAD.B	DEAD BAND	PID	R W
<p>The parameter shows and sets the deadband. The deadband is symmetrical to the setpoint. If the process value (PV) stays in this band, the control output keeps the required power value constant.</p> <p><b>Unit of measurement:</b> Scale points of main input.</p> <p><b>Options:</b> 0...999</p>			

### 4.13.25. FAULT - Fault action power

Acronym	Scrolling message	Submenu	Attributes
FAULT	FAULT ACTION POWER	PID	R W
<p>The parameter shows and sets the fault action power, supplied if the sensor is broken.</p> <p><b>Example</b> If Cntr = HP:CON (Proportional Heat, ON/OFF Cool), the option is On, OFF, 0.0...100.0, i.e., if you set FAULT = On the cooling output will be ON in case of fault.</p> <p><b>Unit of measurement:</b> %</p> <p><b>Options:</b> -100.0...100.0 for P or PI or PID action On, OFF for ON / OFF action</p>			

### 4.13.26. GRAD.I - Setpoint gradient in increase

Acronym	Scrolling message	Submenu	Attributes
GRAD.I	SETPOINT GRADIENT IN INCREMENT	PID	R W
<p>The parameter shows and sets the gradient used when the setpoint value is increased. If the parameter is "0.0" the gradient is disabled.</p> <p><b>Unit of measurement:</b> digit/second or digit/minute, depending on unit parameter setting</p> <p><b>Options:</b> 0.0...999.9</p>			

### 4.13.27. GRAD.D - Setpoint gradient in decrease

Acronym	Scrolling message	Submenu	Attributes
GRAD.D	SETPOINT GRADIENT IN DECREMENT	PID	R W
<p>The parameter shows and sets the gradient used when the setpoint value is decreased. If the parameter is "0.0" the gradient is disabled.</p> <p><b>Unit of measurement:</b> digit/second or digit/minute, depending on unit parameter setting</p> <p><b>Options:</b> 0.0...999.9</p>			

## 4.13.28. Unit - Unit of measurement of gradient

Acronym	Scrolling message	Submenu	Attributes
Unit	GRADIENT UNIT OF MEASURE	PID	R W
<p>The parameter shows and sets the unit of measurement of gradient GRAD.I and GRAD.D. The parameter appears only if GRAD.I or GRAD.D are greater than "0.0".</p> <p><b>Unit of measurement:</b> -</p> <p><b>Options:</b>            <b>DIG/S</b> = Digit/second                           <b>DIG/M</b> = Digit/minute</p>			

## 4.13.29. GRAD.O - Gradient of control output

Acronym	Scrolling message	Submenu	Attributes
GRAD.O	CONTROL OUTPUT GRADIENT	PID	R W
<p>The parameter shows and sets the gradient used by the control output. The gradient is used to limit rapid changes in the control output. If the parameter is "0.0" the gradient is disabled.</p> <p><b>Unit of measurement:</b> % / second</p> <p><b>Options:</b>            <b>0.0...100.0</b></p>			

## 4.13.30. LBA.TM - Tripping delay

Acronym	Scrolling message	Submenu	Attributes
LBA.TM	WAITING TIME FOR LBA ALARM TRIP	PID	R W
<p>The parameter shows and sets the delay time for tripping of the LBA alarm. If the parameter is "0.0" the LBA alarm is disabled. When the LBA alarm is active, it is automatically cancelled if the PV rises (in heating) or lowers (in cooling), or by setting the parameter AL.ACK = On on the user configuration menu or by switching to Manual mode. This parameter will not appear in the presence of ON-OFF control (of heating, cooling and heating/cooling)</p> <p><b>Unit of measurement:</b> Minutes</p> <p><b>Options:</b>            <b>0.0...500.0</b></p>			

## 4.13.31. LBA.PW - Power delivered when LBA alarm trips

Acronym	Scrolling message	Submenu	Attributes
LBA.PW	POWER LIMITS BY LBA ALARM CONDITION	PID	R W
<p>The parameter shows and sets the power value delivered when the LBA alarm trips. This parameter will not appear in the presence of ON-OFF control (of heating, cooling and heating/cooling) In the presence of PID control with ON-OFF heating or cooling, power can only be set for the PID part.</p> <p><b>Unit of measurement:</b> %</p> <p><b>Options:</b>            <b>-100.0...100.0</b></p>			

## 4. CONFIGURATION

### 4.14. PID.GR Submenu – Configuring groups of control parameters

Acronym	Scrolling message	Password	Description
PID.GR	PID GROUP PARAMETERS CONFIG	Level 1	Lets you configure groups of control parameters. Groups of control parameters must be enabled with the parameter PID.GN = .1...4 on the MODE menu (the menu is not shown if PID.GN = 0). Groups are used to preconfigure sets of function parameters that can be easily called when needed, without having to re-configure the PID parameters every time. The number of parameters available in groups is less than the number on the PID submenu. The number of parameters available in groups is limited to those for PID heating and/or cooling control.

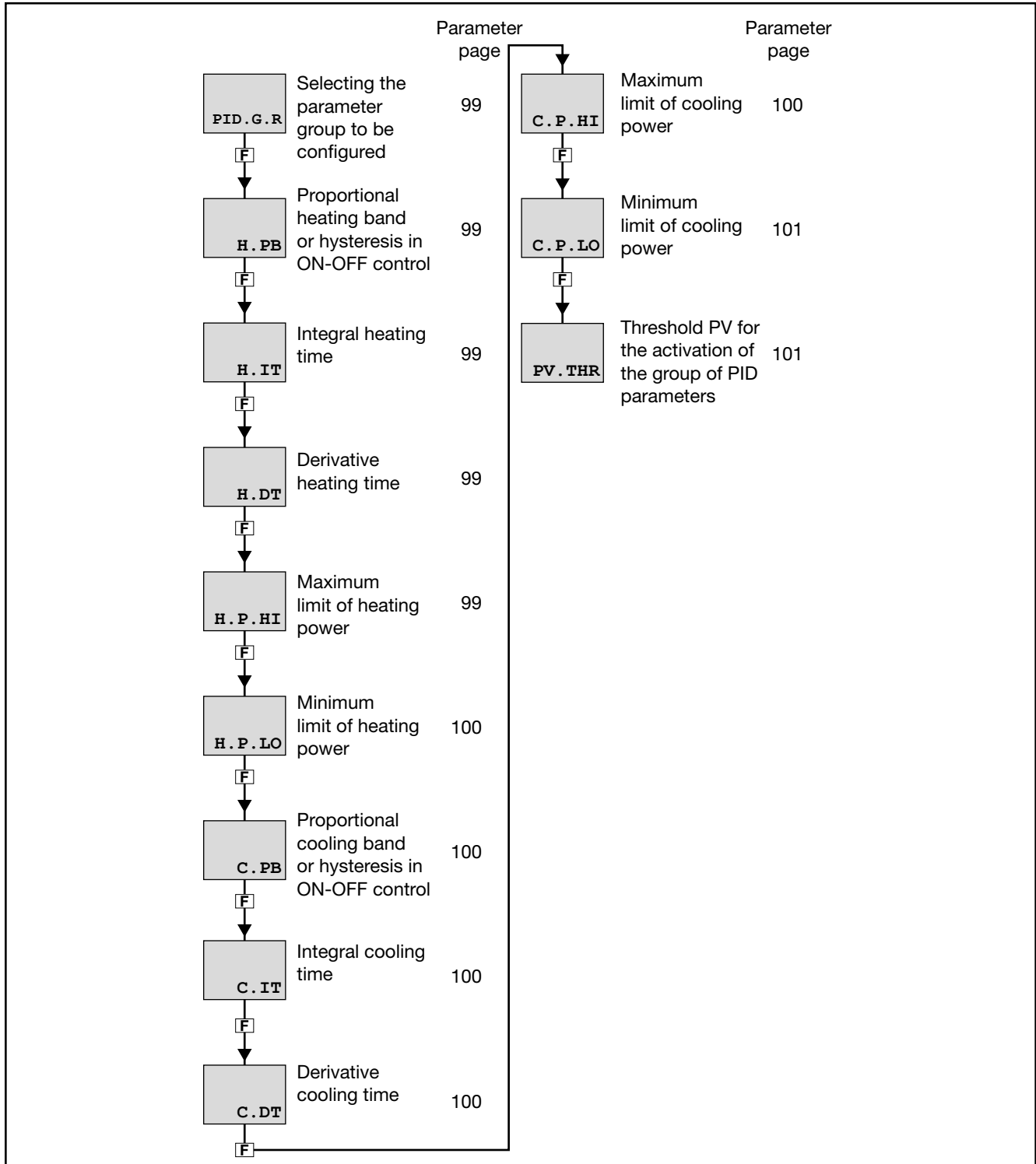

## 4.14.1. PID.G.R - Selecting the parameter group to be configured

Acronym	Scrolling message	Submenu	Attributes
PID.G.R	PID PARAMETERS GROUP NUMBER	PID.GR	R W
<p>The parameter shows and sets the parameter group to be configured, identified by its number.</p> <p><b>Unit of measurement:</b> Number</p> <p><b>Options:</b> 1...PD.G.N = Numerical identification where PID.G.N is the total number of groups of parameters set on the MODE submenu</p>			

## 4.14.2. H.PB - Proportional heating band or hysteresis in ON-OFF control

Acronym	Scrolling message	Submenu	Attributes
H.PB	HEATING PROPORTIONAL BAND OR ON/OFF HYST	PID.GR	R W
<p>The parameter shows and sets the proportional heating band or hysteresis in the ON-OFF control, calculated as a percentage of full scale of the main input.</p> <p><b>Unit of measurement:</b> %</p> <p><b>Options:</b> 0.0...999.9</p>			

## 4.14.3. H.IT - Integral heating time

Acronym	Scrolling message	Submenu	Attributes
H.IT	HEATING INTEGRAL TIME	PID.GR	R W
<p>The parameter shows and sets the integral heating time.</p> <p><b>Unit of measurement:</b> Minutes</p> <p><b>Options:</b> 0.00...99.99</p>			

## 4.14.4. H.DT - Derivative heating time

Acronym	Scrolling message	Submenu	Attributes
H.DT	HEATING DERIVATIVE TIME	PID.GR	R W
<p>The parameter shows and sets the derivative heating time.</p> <p><b>Unit of measurement:</b> Minutes</p> <p><b>Options:</b> 0.00...99.99</p>			

## 4.14.5. H.P.HI - Maximum heating power

Acronym	Scrolling message	Submenu	Attributes
H.P.HI	HEATING POWER HIGH LIMIT	PID.GR	R W
<p>The parameter shows and sets the maximum limit of heating power.</p> <p><b>Unit of measurement:</b> %</p> <p><b>Options:</b> 0.0...100.0</p>			

## 4. CONFIGURATION

### 4.14.6. H.P.LO - Minimum limit of heating power

Acronym	Scrolling message	Submenu	Attributes
H.P.LO	HEATING POWER LOW LIMIT	PID.GR	R W
<p>The parameter shows and sets the minimum limit of heating power. For details, see paragraph "4.13.12. H.P.LO – Minimum limit of heating power" on page "4.13.12. H.P.LO - Minimum limit of heating power" on page 93.</p> <p><b>Unit of measurement:</b> %</p> <p><b>Options:</b> 0.0...100.0</p>			

### 4.14.7. C.PB - Proportional cooling band or hysteresis in ON-OFF control

Acronym	Scrolling message	Submenu	Attributes
C.PB	COOLING PROPORTIONAL BAND OR ON/OFF HYST	PID.GR	R W
<p>The parameter shows and sets the proportional cooling band or hysteresis in the ON-OFF control, calculated as a percentage of full scale of the main input.</p> <p><b>Unit of measurement:</b> %</p> <p><b>Options:</b> 0.0...999.9</p>			

### 4.14.8. C.IT - Integral cooling time

Acronym	Scrolling message	Submenu	Attributes
C.IT	COOLING INTEGRAL TIME	PID.GR	R W
<p>The parameter shows and sets the integral cooling time.</p> <p><b>Unit of measurement:</b> Minutes</p> <p><b>Options:</b> 0.00...99.99</p>			

### 4.14.9. C.DT - Derivative cooling time

Acronym	Scrolling message	Submenu	Attributes
C.DT	COOLING DERIVATIVE TIME	PID.GR	R W
<p>The parameter shows and sets the derivative cooling time.</p> <p><b>Unit of measurement:</b> Minutes</p> <p><b>Options:</b> 0.00...99.99</p>			

### 4.14.10. C.P.HI - Maximum limit of cooling power

Acronym	Scrolling message	Submenu	Attributes
C.P.HI	COOLING POWER HIGH LIMIT	PID.GR	R W
<p>The parameter shows and sets the maximum limit of cooling power.</p> <p><b>Unit of measurement:</b> %</p> <p><b>Options:</b> 0.0...100.0</p>			

## 4.14.11. C.P.LO - Minimum limit of cooling power

Acronym	Scrolling message	Submenu	Attributes
C.P.LO	COOLING POWER LOW LIMIT	PID.GR	R W
<p>The parameter shows and sets the minimum limit of cooling power. For details, see paragraph "4.13.9. H.IT – Integral heating time" on page "4.13.9. H.IT - Integral heating time" on page 93.</p> <p><b>Unit of measurement:</b>    %</p> <p><b>Options:</b>                0.0...100.0</p>			

## 4.14.12. PV.THR - Threshold PV for the activation of the group of PID parameters

Acronym	Scrolling message	Submenu	Attributes
PV.THR	PV BEYOND WHICH IS ACTIVE PARAMETER GROUP	PID.GR	R W
<p>The parameter shows and sets the PV over which the group of PID parameters is active.</p> <p><b>Unit of measurement:</b>    Scale points of main input</p> <p><b>Options:</b>                LO.SCL...HI.SCL</p>			

## 4. CONFIGURATION

### 4.15. I.DIGT Submenu – Configuring digital inputs

Acronym	Scrolling message	Password	Description
I.DIGT	DIGITAL INPUT CONFIG	Level 2	Lets you configure the controller's digital inputs. The menu is present if there are digital inputs.

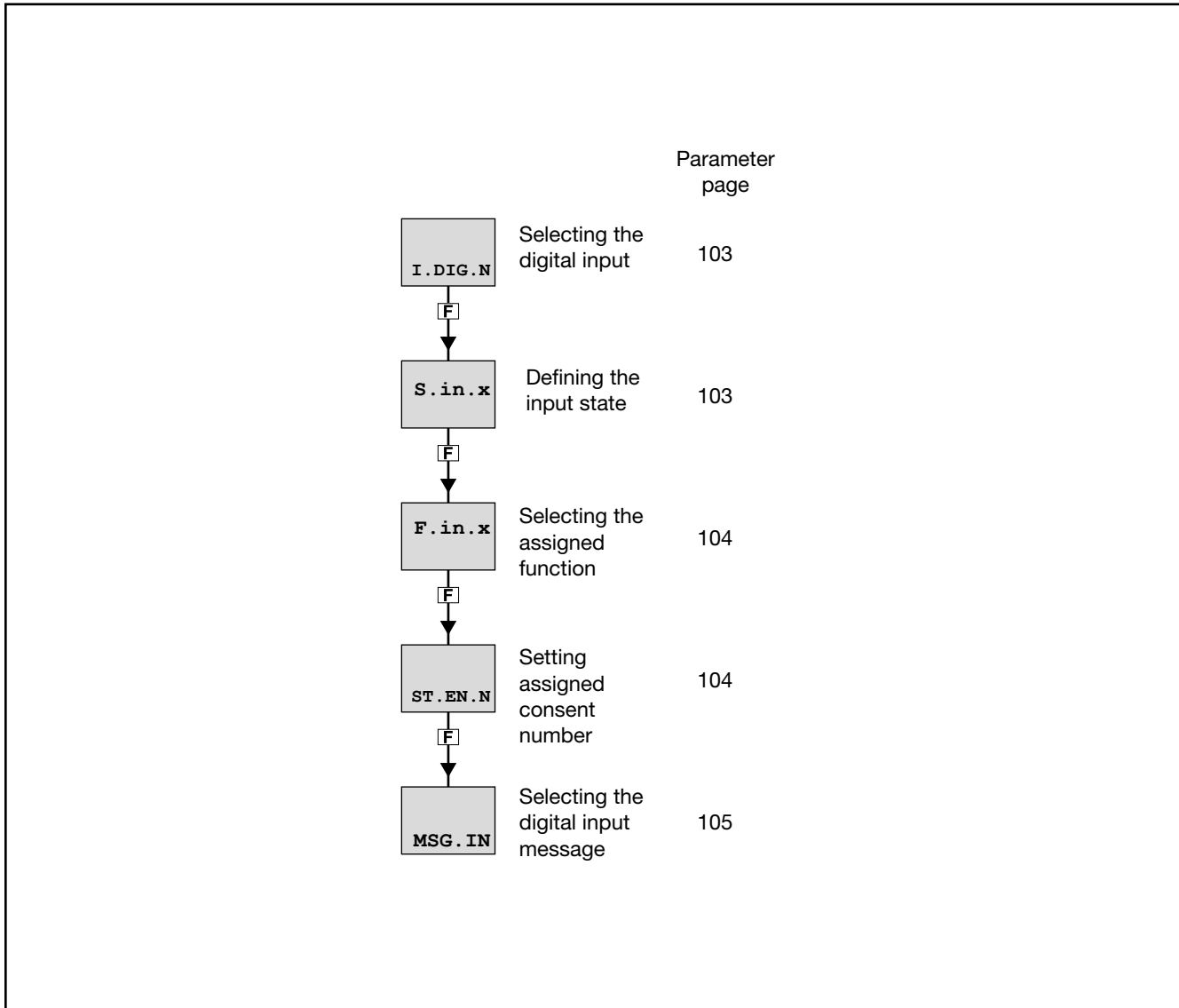

## 4.15.1. I.DIG.N - Selecting the digital input

Acronym	Scrolling message	Submenu	Attributes
I.DIG.N	DIGITAL INPUT NUMBER	I.DIGT	R W
<p>The parameter shows and sets the identifying number of the digital input to be configured.</p> <p><b>Unit of measurement:</b> Number</p> <p><b>Options:</b></p> <ul style="list-style-type: none"> <li><b>1...2</b> for model 6140 with 2 digital inputs option</li> <li><b>1...3</b> for model 6140 with 3 digital inputs option</li> <li><b>1...5</b> for models 4140 with 5 digital inputs option</li> </ul>			

## 4.15.2. S.in.x - Defining the input state

Acronym	Scrolling message	Submenu	Attributes
S.in.x	DIGITAL INPUT STATUS	I.DIGT	R W
<p>The parameter shows and sets the state of the input with identifying number "x".</p> <p>The direct digital input is active when there is current in the digital input or the contact is closed.</p> <p>The inverse digital input is active when there is no current in the digital input or the contact is open.</p> <p>Digital inputs can be forced so that they are always on or off.</p> <p><b>Unit of measurement:</b> -</p> <p><b>Options:</b></p> <ul style="list-style-type: none"> <li><b>DIREC</b> = Direct digital input</li> <li><b>INVRS</b> = Inverse digital input</li> <li><b>OFF</b> = Digital input forced off</li> <li><b>ON</b> = Digital input forced on</li> </ul>			

## 4. CONFIGURATION

### 4.15.3. F.in.x - Selecting the assigned function

Acronym	Scrolling message	Submenu	Attributes
F.in.x	DIGITAL INPUT FUNCTION	I.DIGT	R W
<p>The parameter shows and sets the function assigned to the digital input with identifying number "x".</p> <p><b>Unit of measurement:</b> -</p> <p><b>Options:</b></p> <p><b>NONE</b> = No assigned function</p> <p><b>AU-MA</b> = Automatic-Manual control</p> <p><b>LO-RE</b> = Local-Remote setpoint mode</p> <p><b>HOLD</b> = Hold value of main input</p> <p><b>AL.ACK</b> = Reset alarm latches</p> <p><b>S.TUNE</b> = Activate Self-Tuning</p> <p><b>A.TUNE</b> = Activate Auto-Tuning</p> <p><b>ON-OFF</b> = Software ON-OFF</p> <p><b>FKEY</b> = Block F key</p> <p><b>WRI.EN</b> = Enable writing of configuration parameters</p> <p><i>if the Multiset function is enabled:</i></p> <p><b>SEL.L</b> = Select setpoint SETP1...SETP2 or SETP1...SETP4 low bit</p> <p><b>SEL.H</b> = Select set point SETP1...SETP4 high bit Model "Programmer enabled SEL.L and SEL.H" have the meaning of selection Nr. program</p> <p><i>if the Timer function is enabled:</i></p> <p><b>T.STST</b> = START/STOP timer</p> <p><b>T.RST</b> = RESET timer</p> <p><i>if the Programmer function is enabled:</i></p> <p><b>P.STST</b> = START/STOP programmer base times</p> <p><b>P.STRT</b> = START programmer base times</p> <p><b>P.STOP</b> = STOP programmer base times</p> <p><b>P.RST</b> = RESET programmer base times</p> <p><b>P.SKIP</b> = SKIP to end of program (end cycle)</p> <p><b>ST.SKIP</b> = SKIP to end of step</p> <p><b>ST.ENB</b> = STEP ENABLE: input with consent function at start of step</p> <p><i>if the Logic Options function is enabled:</i></p> <p><b>FB.IN</b> = Function Blocks Input</p> <p><b>KEY.U</b> = replica UP button</p> <p><b>KEY.D</b> = replica DOWN button</p> <p><b>KEY.F</b> = replica F button</p>			

### 4.15.4. ST.EN.N - Setting assigned consent number

Acronym	Scrolling message	Submenu	Attributes
ST.EN.N	ENABLE NUMBER	I.DIGT	R W
<p>The parameter shows and sets the consent number assigned to the digital input identified by I.DIG.N.</p> <p>The parameter appears if the parameter F.in.x = ST.ENB.</p> <p><b>Unit of measurement:</b> Number</p> <p><b>Options:</b> 1...4</p>			

## 4.15.5. MSG.IN - Selecting the digital input message

Acronym	Scrolling message	Submenu	Attributes
MSG.IN	NUMBER OF SCROLLING MESSAGE AT INPUT ACT	I.DIGT	R W
<p>The parameter shows and sets the number of the message assigned to activation of the digital input, i.e., the scrolling message shown on the display.</p> <p>For more information on scrolling messages, see paragraph “3.1.2.2. Scrolling messages” on page 34.</p> <p>If the parameter is set to “0” no message will be displayed when the digital input is activated.</p> <p>The same message number can be assigned to different inputs.</p> <p><b>Unit of measurement:</b> Message number</p> <p><b>Options:</b> 0...25</p>			

## 4. CONFIGURATION

### 4.16. OUTPU Submenu – Configuring outputs

Acronym	Scrolling message	Password	Description
OUTPU	OUTPUT CONFIG	Level 2	Lets you configure the controller outputs.

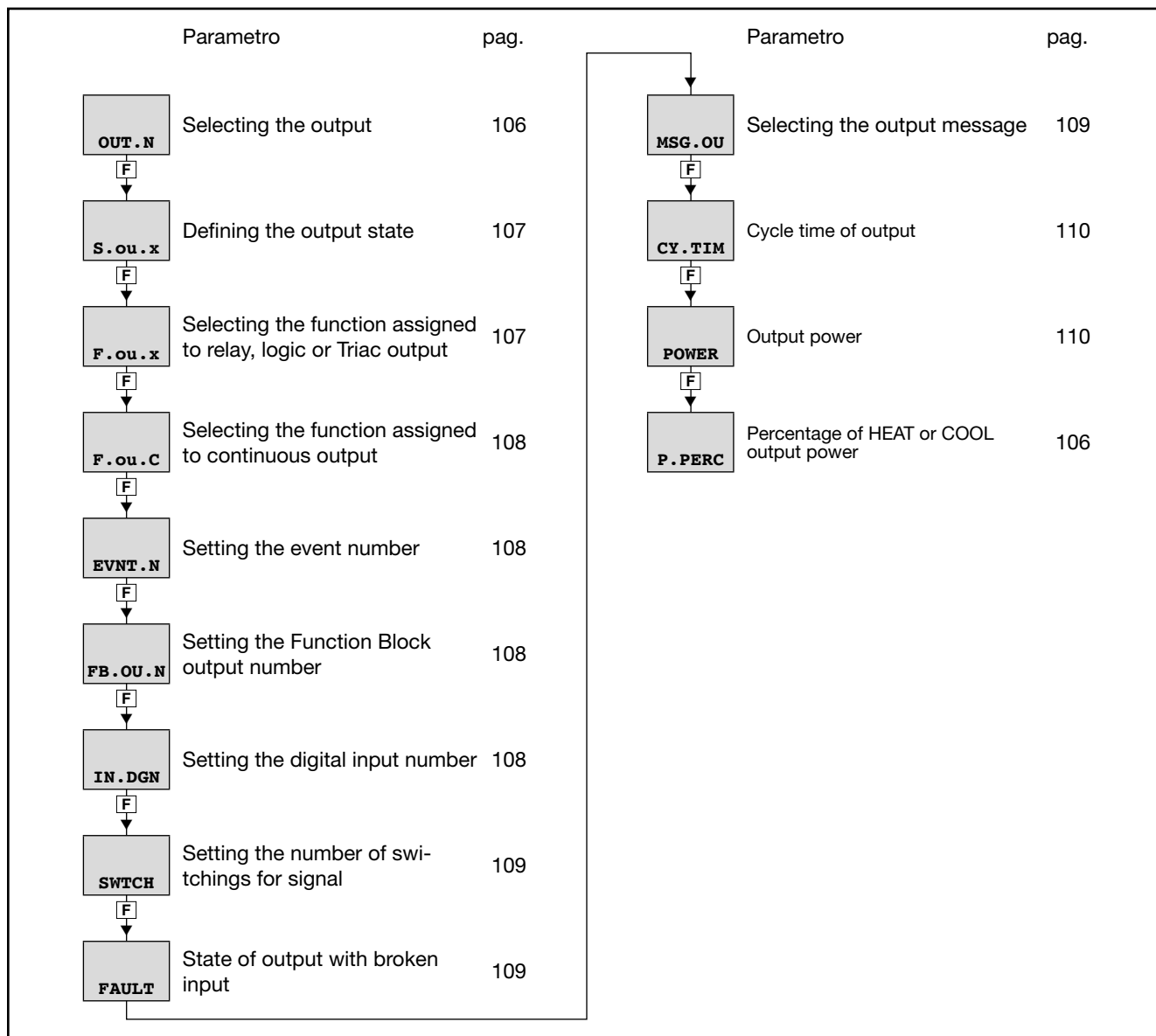

#### 4.16.1. OUT.N - Selecting the output

Acronym	Scrolling message	Submenu	Attributes
OUT.N	OUTPUT NUMBER	OUTPU	R W

The parameter shows and sets the identifying number of the output to be configured.

**Unit of measurement:** Number

**Options:** 1...4

## 4.16.2. S.ou.x - Defining the output state

Acronym	Scrolling message	Submenu	Attributes
S.ou.x	DIGITAL OUTPUT STATUS	OUTPU	R W
<p>The parameter shows and sets the state of the output with identifying number "x".            The active direct output corresponds to the relay, logic, or triac output ON (conducting).            The active inverse output corresponds to the relay, logic, or triac output OFF.            If the output is continuous, direct corresponds to minimum = 4mA and maximum = 20 mA, while inverse corresponds to minimum = 20 mA and maximum = 4 mA.            The outputs can be forced so that they are always on or off.</p> <p><b>Unit of measurement:</b> -</p> <p><b>Options:</b></p> <p><b>DIREC</b> = Direct output  <b>INVRS</b> = Inverse output  <b>OFF</b> = Output forced off  <b>ON</b> = Output forced on</p>			

## 4.16.3. F.ou.x - Selecting the function assigned to relay, logic or Triac output

Acronym	Scrolling message	Submenu	Attributes
F.ou.x	OUTPUT FUNCTION	OUTPU	R W
<p>The parameter shows and sets the function assigned to the output with identifying number "x", if the output is relay, logic or triac and is direct or inverse.</p> <p><b>Unit of measurement:</b> -</p> <p><b>Options:</b></p> <p><b>NONE</b> = No assigned function  <b>HEAT</b> = Heat control output  <b>COOL</b> = Cool control output  <b>ALRM1</b> = Output for Alarm 1  <b>ALRM2</b> = Output for Alarm 2  <b>ALRM3</b> = Output for Alarm 3  <b>ALRM4</b> = Output for Alarm 4  <b>OR.12</b> = Alarm 1 OR Alarm 2  <b>OR.123</b> = Alarm 1 OR Alarm 2 OR Alarm 3  <b>O.1234</b> = Alarm 1 OR Alarm 2 OR Alarm 3 OR Alarm 4  <b>AND.12</b> = Alarm 1 AND Alarm 2  <b>AND.123</b> = Alarm 1 AND Alarm 2 AND Alarm 3  <b>AND.1234</b> = Alarm 1 AND Alarm 2 AND Alarm 3 AND Alarm 4  <b>AL.HB</b> = Output for HB alarm  <b>LBA</b> = Output for LBA alarm  <b>BUT.SR</b> = Set/Reset from key</p> <p><i>if the Timer function is enabled:</i>  <b>TIMER</b> = Timer state (end of count)</p> <p><i>if the Programmer function is enabled:</i>  <b>P.HBB</b> = HBB alarm of programmer  <b>P.RUN</b> = RUN state of programmer  <b>P.HOLD</b> = STOP state of programmer  <b>P.RDY</b> = READY state of programmer (after reset of time base)  <b>P.END</b> = END state of programmer  <b>EVENT</b> = EVENT state of programmer</p> <p><i>if model with Logic Operations:</i>  <b>FB.OUT</b> = Output of Function Blocks</p> <p><i>if model with valve control:</i>  <b>V.OPEN</b> = Output for the opening of the valve  <b>V.CLOS</b> = Output for the closure of the valve</p> <p><i>if model with digital inputs:</i>  <b>IN.DIG</b> = Repetition of a digital input</p> <p><b>POWER</b> = Power output defined by the POWER parameter</p>			

## 4. CONFIGURATION

### 4.16.4. F.ou.C - Selecting the function assigned to continuous output

Acronym	Scrolling message	Submenu	Attributes
F.ou.C	REFERENCE SIGNAL CONTINUE OUTPUT	OUTPU	R W
<p>The parameter shows and sets the function assigned to continuous output 1, direct or inverse.</p> <p><b>Unit of measurement:</b> -</p> <p><b>Options:</b></p> <ul style="list-style-type: none"> <li><b>NONE</b> = No assigned function</li> <li><b>HEAT</b> = Heat control output</li> <li><b>COOL</b> = Cool control output</li> <li><b>PV</b> = Process variable</li> <li><b>SSP</b> = Active setpoint</li> <li><b>SP</b> = Local setpoint</li> <li><b>SP-PV</b> = Deviation  SSp-PV </li> <li><b>SERIA</b> = Value set from serial line</li> </ul>			

### 4.16.5. EVNT.N - Setting the event number

Acronym	Scrolling message	Submenu	Attributes
EVNT.N	EVENT NUMBER	OUTPU	R W
<p>The parameter shows and sets the event number. The parameter appears if the parameter F.ou.x = EVENT.</p> <p><b>Unit of measurement:</b> Number</p> <p><b>Options:</b> 1...4</p>			

### 4.16.6. FB.OU.N - Setting the Function Block output number

Acronym	Scrolling message	Submenu	Attributes
FB.OU.N	FUNCTION BLOCK OUTPUT NUMBER	OUTPU	R W
<p>The parameter shows and sets the number of the Function Block assigned to the output. The parameter appears if the parameter F.ou.x = FB.OUT.</p> <p><b>Unit of measurement:</b> Number</p> <p><b>Options:</b> 1...16</p>			

### 4.16.7. IN.DG.N - Setting the digital input number

Acronym	Scrolling message	Submenu	Attributes
IN.DG.N	DIGITAL INPUT NUMBER	OUTPU	R W
<p>The parameter shows and sets the number of the digital input assigned to the output. The parameter appears if the parameter F.ou.x = IN.DIG.</p> <p><b>Unit of measurement:</b> Number</p> <p><b>Options:</b></p> <ul style="list-style-type: none"> <li><b>1...2</b> Model 6140 with option 2 digital inputs</li> <li><b>1...3</b> Model 6140 with option 3 digital inputs</li> <li><b>1...5</b> Model 4140 with option 5 digital inputs</li> </ul>			

## 4.16.8. SWTCH - Setting the number of switchings for signal

Acronym	Scrolling message	Submenu	Attributes
SWTCH	NUMBER OF SWITCHING CYCLES	OUTPU	R W
<p>The parameter shows and sets the number of switchings (x1000) of the relay, exceeding which the signal is generated OUTX.SWITCH ALARM where X is the number of output 1 or 2 or 3 or 4 if the output is relay, logic or triac. The function is disabled if the parameter equals "0".</p> <p>CAUTION: The minimum counting unit is 1000 ON-OFF switching operations. The alarm is therefore triggered for values strictly greater than the set SWTCH parameter (e.g. if SWTCH is set to 1, the alarm is not triggered at 1000 + 1 switches, but at 1000 + 1000 switches = 2000).</p> <p><b>Unit of measurement:</b> Number</p> <p><b>Options:</b> 0...9999</p>			

## 4.16.9. FAULT - State of output with broken input

Acronym	Scrolling message	Submenu	Attributes
FAULT	FAULT OUTPUT STATE	OUTPU	R W
<p>The parameter shows and sets the state (on, off) that the output assumes in case of broken input (Err, Sbr, ...), if the output is direct or inverse and operation in automatic mode.</p> <p><b>Unit of measurement:</b> -</p> <p><b>Options:</b>           <b>OFF</b>    = Output is off                            <b>On</b>        = Output is on                            <b>nOnE</b>   = The output continues to function normally</p>			

## 4.16.10. MSG.OU - Selecting the output message

Acronym	Scrolling message	Submenu	Attributes
MSG.OU	NUMBER OF SCROLLING MESSAGE AT OUTPUT ACT	OUTPU	R W
<p>The parameter shows and sets the number of the message assigned to activation of the output, i.e., the scrolling message shown on the display.</p> <p>For more information on scrolling messages, see paragraph "3.1.2.2. Scrolling messages" on page 34.</p> <p>If the parameter is set to "0" no message will be displayed when the output is activated.</p> <p>The same message number can be assigned to different outputs.</p> <p><b>Unit of measurement:</b> Message number</p> <p><b>Options:</b> 0...25</p>			

## 4. CONFIGURATION

### 4.16.11. CY.TIM - Cycle time of output

Acronym	Scrolling message	Submenu	Attributes
CY.TIM	CYCLE TIME	OUTPU	R W
<p>The parameter shows and sets the slicing period of the output. The parameter appears if the parameter F.ou.x = HEAT or F.ou.x = COOL or F.ou.x = POWER.</p> <p>The slicing period is the cycle time, i.e., the sum of ON time and OFF time proportional to the value of Heat or Cool power.</p> <p><b>Example</b> If Heat power is 25% and the 25% the cycle time is 10.0 seconds, the output is active for 2.5 seconds and inactive for 7.5 seconds.</p> <p>Burst Firing (BF) mode has a variable cycle time, optimized to transfer power as quickly as possible. The minimum interval for ON or OFF equals the electrical cycle (20 ms at 50 Hz). The ON and OFF times are multiples of the minimum time.</p> <p><b>Example</b> If Heat power is 25% and the line frequency is 50 Hz, the cycle time is 80 ms. The output is active for 20 ms and inactive for 60 ms (= 3 × 20 ms, equal to the remaining 75% of the cycle time).</p> <p><b>Unit of measurement:</b> Seconds</p> <p><b>Options:</b>            <b>0.0...20.0</b>    for digital and Triac outputs. There is Burst Firing (BF) with 0.0.                           <b>1...200</b>        for relay output</p>			

### 4.16.12. POWER - Power of output

Acronym	Scrolling message	Submenu	Attributes
POWER	OUTPUT POWER	OUTPU	R W
<p>The parameter shows and sets the slicing period of the output.</p> <p>The parameter appears if the parameter F.ou.x = POWER.</p> <p><b>Unit of measurement:</b> %</p> <p><b>Options:</b>            <b>0.0...100.0</b></p>			

### 4.16.13. P.PERC - Percentage of HEAT or COOL output power

Acronym	Scrolling message	Submenu	Attributes
P.PERC	OUTPUT POWER PERCENTAGE	OUTPU	R W
<p>The parameter shows and sets the percentage of HEAT or COOL output power that is actually implemented by the output</p> <p>The parameter appears if the parameter F.ou.x = HEAT or F.ou.x = COOL.</p> <p><b>Unit of measurement:</b> %</p> <p><b>Options:</b>            <b>0.0...100.0 (default = 100.0%)</b></p>			

### 4.17. OUT.AN - Submenu – Configuring the analog retransmission output

Acronym	Scrolling message	Password	Description
OUT.AN	ANALOG RETRASMISSION OUTPUT CONFIG	Level 2	Lets you configure the analog output used for retransmission of analog values.  The submenu appears if the analog retransmission output is present on the controller.

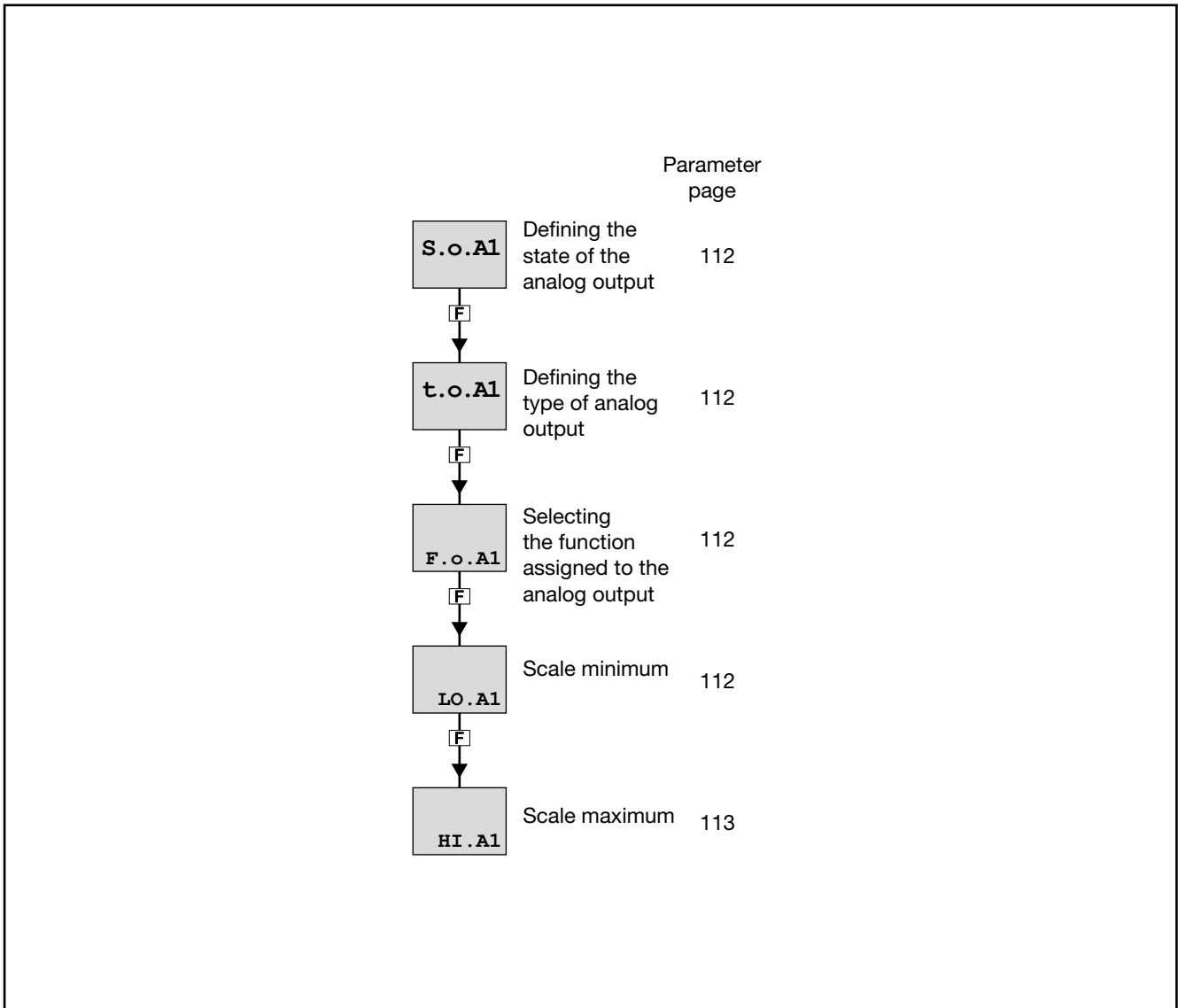

## 4. CONFIGURATION

### 4.17.1. S.o.A1 - Defining the state of the analog output

Acronym	Scrolling message	Submenu	Attributes
S.o.A1	ANALOG OUTPUT STATUS	OUT.AN	R W
<p>The parameter shows and sets the state of analog retransmission output A1.                      The active direct output corresponds to minimum with the minimum output value in voltage or current.                      The active inverse output corresponds to minimum with the maximum output value in voltage or current.                      The outputs can be forced so that they are always on or off.</p> <p><b>Unit of measurement:</b> -</p> <p><b>Options:</b></p> <ul style="list-style-type: none"> <li><b>DIREC</b> = Direct output</li> <li><b>INVRS</b> = Inverse output</li> <li><b>OFF</b> = Forced output inactive (minimum voltage or current value)</li> <li><b>ON</b> = Forced output active (maximum voltage or current value)</li> </ul>			

### 4.17.2. t.o.A1 - Defining the type of analog output

Acronym	Scrolling message	Submenu	Attributes
t.o.A1	ANALOG OUTPUT TYPE	OUT.AN	R W
<p>The parameter shows and sets the definition of analog output A1.</p> <p><b>Unit of measurement:</b> -</p> <p><b>Options:</b></p> <ul style="list-style-type: none"> <li><b>20MA</b> = Output 0...20 mA</li> <li><b>4-20M</b> = Output 4...20 mA</li> <li><b>10V</b> = Output 0...10 V</li> <li><b>2-10V</b> = Output 2...10 V</li> <li><b>C.20MA</b> = Custom Output 0...20 mA</li> <li><b>C.4-20</b> = Custom Output 4...20 mA</li> <li><b>C.10V</b> = Custom Output 0...10 V</li> <li><b>C.2-10</b> = Custom Output 2...10 V</li> </ul>			

### 4.17.3. F.o.A1 - Selecting the function assigned to the analog output

Acronym	Scrolling message	Submenu	Attributes
F.o.A1	REFERENCE SIGNAL ANALOG OUTPUT	OUT.AN	R W
<p>The parameter shows and sets the function assigned (retransmission of values) to analog output A1.</p> <p><b>Unit of measurement:</b> -</p> <p><b>Options:</b></p> <ul style="list-style-type: none"> <li><b>NONE</b> = No assigned function</li> <li><b>HEAT</b> = Heat control power</li> <li><b>COOL</b> = Cool control power</li> <li><b>PV</b> = Process variable</li> <li><b>SSP</b> = Active setpoint</li> <li><b>SP</b> = Local setpoint</li> <li><b>SP-PV</b> = Deviation  SP-PV </li> <li><b>SERIA</b> = Value set from serial line</li> </ul> <p><i>if the Programmer function is enabled:</i></p> <ul style="list-style-type: none"> <li><b>SLV.SP</b> = Slaved setpoint</li> </ul>			

### 4.17.4. LO.A1 - Scale minimum

Acronym	Scrolling message	Submenu	Attributes
LO.A1	LOW LIMIT ANALOG OUTPUT	OUT.AN	R W
<p>The parameter shows and sets the scale minimum, which corresponds to minimum output value in voltage or current.</p> <p><b>Unit of measurement:</b> Scale points of quantity assigned to analog output.</p> <p><b>Options:</b> -1999...9999</p>			

## 4.17.5. HI.A1 - Scale maximum

Acronym	Scrolling message	Submenu	Attributes
HI.A1	HIGH LIMIT ANALOG OUTPUT	OUT.AN	R W
<p>Il parametro mostra e imposta il massimo di scala, che corrisponde al massimo dell'uscita in tensione o corrente.</p> <p><b>Unit of measurement:</b> Scale points of quantity assigned to analog output.</p> <p><b>Options:</b> -1999...9999</p>			

## 4. CONFIGURATION

### 4.18. VALVE Submenu – Configuring valve parameters

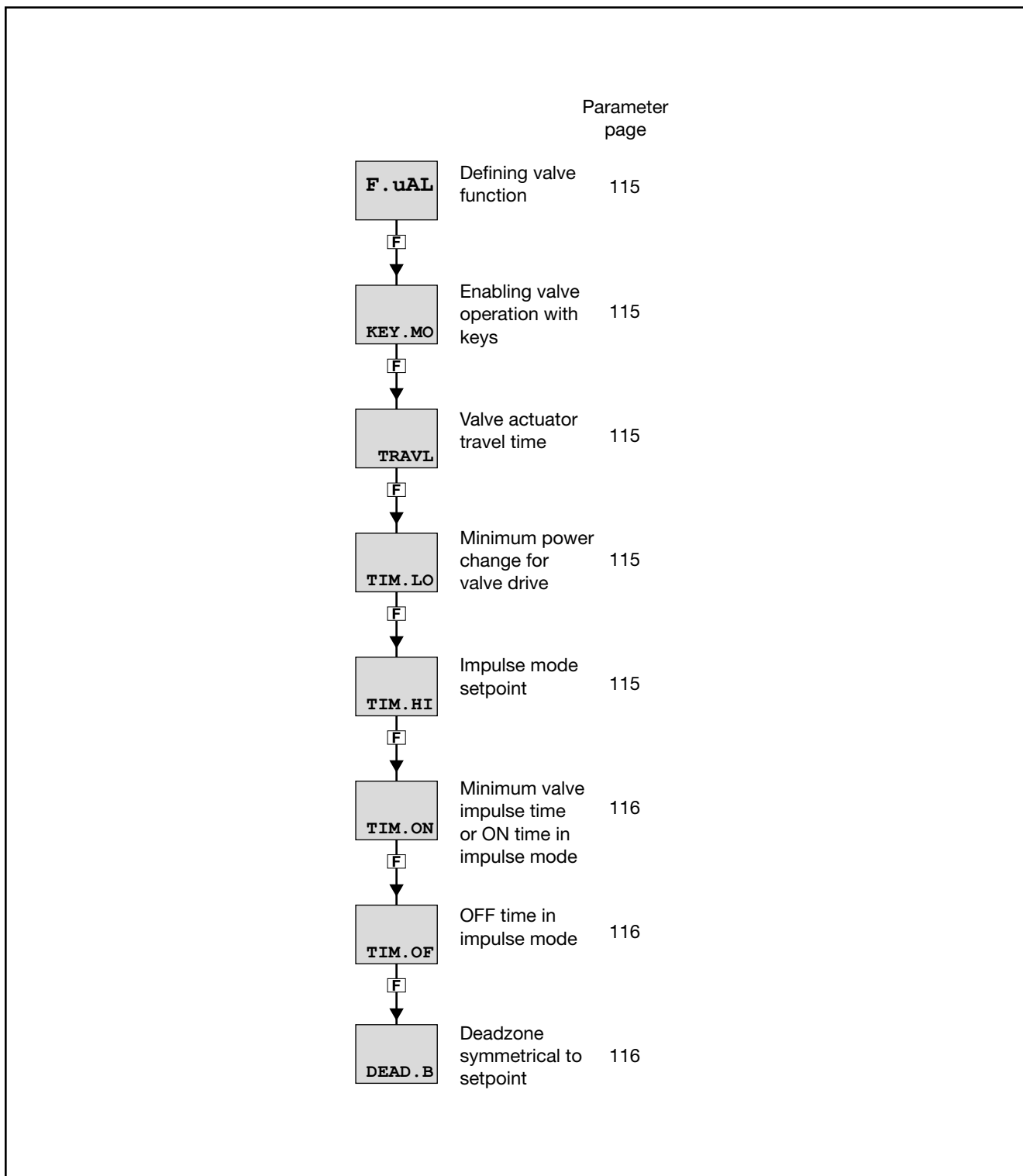

Acronym	Scrolling message	Password	Description
VALVE	VALVE MANAGER	Level 2	Lets you configure control parameters for motorized valves. The submenu appears if the controller is set for valve control.



## 4.18.1. F.uAL - Defining valve function

Acronym	Scrolling message	Submenu	Attributes
F.uAL	VALVE CONTROL TYPE	VALVE	R W
<p>The parameter shows and sets the valve function, i.e., if it controls a heating or cooling system.</p> <p><b>Unit of measurement:</b> -</p> <p><b>Options:</b>           <b>HEAT</b> = Heat control power                           <b>COOL</b> = Cool control power</p>			

## 4.18.2. KEY.MO - Enabling valve operation with keys

Acronym	Scrolling message	Submenu	Attributes
KEY.MO	VALVE OPEN/CLOSE FROM IN/DEC BUTT ENABLE	VALVE	R W
<p>The parameter shows and sets enabling of valve opening and closing with controller keys  and  in manual mode.</p> <p><b>Unit of measurement:</b> -</p> <p><b>Options:</b>           <b>OFF</b> = Keys do not act directly on valve opening and closing                           <b>On</b> = Keys enabled for manual valve opening and closing</p>			

## 4.18.3. TRAVL - Valve actuator travel time

Acronym	Scrolling message	Submenu	Attributes
TRAVL	ACTUATOR TRAVEL TIME	VALVE	R W
<p>The parameter shows and sets the time taken by the actuator to bring the valve from “full open” position to “full closed” position or vice versa. The time is obtained by trial or deduced from the valves technical data.</p> <p><b>Unit of measurement:</b> Seconds</p> <p><b>Options:</b>           <b>0...2000</b></p>			

## 4.18.4. TIM.LO - Minimum power change for valve drive

Acronym	Scrolling message	Submenu	Attributes
TIM.LO	MINIMUM PULSE TIME	VALVE	R W
<p>The parameter shows and sets the minimum power change needed to drive the valve. The parameter is calculated as a percentage of the TRAVL parameter and serves to prevent excess activity of the valve, with consequent electromechanical stress. The control function is explained in detail in paragraph “5.14. Managing motorized valves” on page “5.14. Managing motorized valves” on page 162.</p> <p><b>Unit of measurement:</b> % of TRAVL</p> <p><b>Options:</b>           <b>0.0...25.0</b></p>			

## 4.18.5. TIM.HI - Impulse mode setpoint

Acronym	Scrolling message	Submenu	Attributes
TIM.HI	IMPULSIVE MODE INTERVENTION THRESHOLD	VALVE	R W
<p>The parameter shows and sets the impulse mode setpoint as a percentage of valve opening time TRAVL. The control function is explained in detail in paragraph “5.14. Managing motorized valves” on page “5.14. Managing motorized valves” on page 162.</p> <p><b>Unit of measurement:</b> % of TRAVL</p> <p><b>Options:</b>           <b>0.0...100.0</b></p>			

## 4. CONFIGURATION

### 4.18.6. TIM.ON - Minimum valve impulse time or ON time in impulse mode

Acronym	Scrolling message	Submenu	Attributes
TIM.ON	ON TIME FOR IMPULSIVE MODE	VALVE	R W
<p>The parameter shows and sets the minimum valve impulse time or ON time in impulse mode as a percentage of valve opening time TRAVL.</p> <p><b>Unit of measurement:</b> % of TRAVL</p> <p><b>Options:</b> 0.0...100.0</p>			

### 4.18.7. TIM.OF - OFF time in impulse mode

Acronym	Scrolling message	Submenu	Attributes
TIM.OF	OFF TIME FOR IMPULSIVE MODE	VALVE	R W
<p>The parameter shows and sets OFF time in impulse mode as a percentage of valve opening time TRAVL. A value below TIM.ON is forced to TIM.ON. The TIM.ON and TIM.OF functions are both excluded if the parameter equals "0.0".</p> <p><b>Unit of measurement:</b> % of TRAVL</p> <p><b>Options:</b> 0.0...100.0</p>			

### 4.18.8. DEAD.B - Deadzone symmetrical to setpoint

Acronym	Scrolling message	Submenu	Attributes
DEAD.B	DEAD ZONE	VALVE	R W
<p>The parameter shows and sets a band symmetrical to the setpoint. If PV is in this band, valve activity and the related integral action is stopped. It prevents frequent corrections of the valve position, with consequent electromechanical stress, following small changes in the value of the PV.</p> <p><b>Unit of measurement:</b> % of full scale of main input</p> <p><b>Options:</b> 0.0...25.0</p>			

### 4.19. MODE Submenu – Configuring functioning mode

Acronym	Scrolling message	Password	Description
MODE	FUNCTION MODE MANAGER	Level 2	Lets you configure the controller's functioning mode.

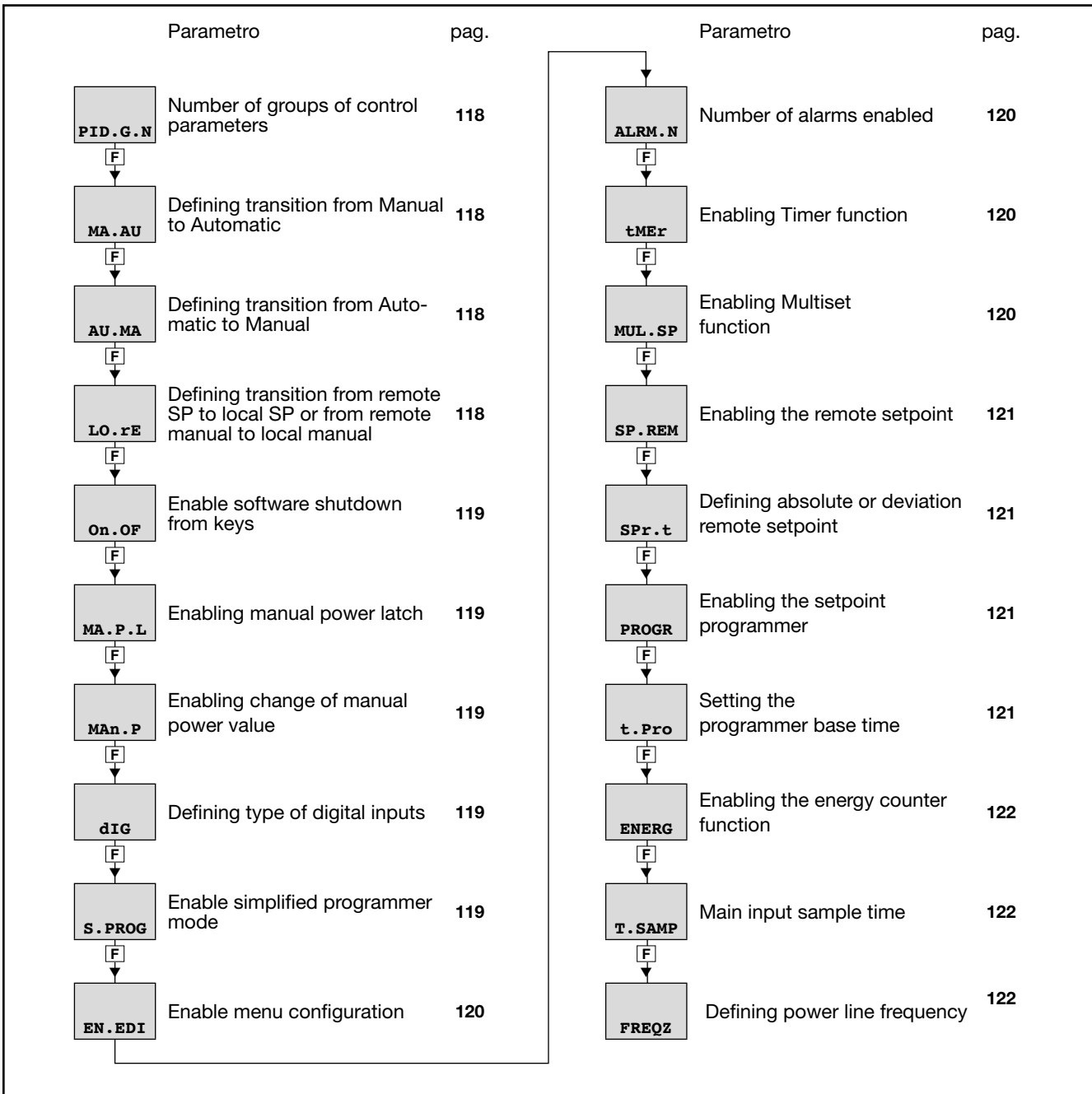

## 4. CONFIGURATION

### 4.19.1. PID.G.N - Number of groups of control parameters

Acronym	Scrolling message	Submenu	Attributes
PID.G.N	NUM OF CONTROL PARAMETERS GROUP	MODE	R W
<p>The parameter shows and sets the number of the groups of PID parameters. The groups of control parameters are disabled if the parameter equals "0".</p> <p><b>Unit of measurement:</b> Number</p> <p><b>Options:</b> 0...4</p>			

### 4.19.2. MA.AU - Defining transition from Manual to Automatic

Acronym	Scrolling message	Submenu	Attributes
MA.AU	MANUAL TO AUTOMATIC TRANSITION TYPE	MODE	R W
<p>The parameter shows and sets controller behavior when switching from manual to automatic mode.</p> <p>With STAND, the POWER output assumes the value calculated by the PID based on the local or remote SP (bumpless PID with integral action based on actual PV-SP and power values).</p> <p>With BUMPL, the local setpoint assumes the PV value (bumpless PID with integral action based on actual power value). PV-SP = 0.</p> <p><b>Unit of measurement:</b> -</p> <p><b>Options:</b> STAND BUMPL</p>			

### 4.19.3. AU.MA - Defining transition from Automatic to Manual

Acronym	Scrolling message	Submenu	Attributes
AU.MA	AUTOMATIC TO MANUAL TRANSITION TYPE	MODE	R W
<p>The parameter shows and sets controller behavior when switching from automatic to manual mode.</p> <p>With STAND, the control output assumes the local or remote POWER value.</p> <p>With BUMPL, the value of the control output does not change. In case of remote manual control, the control acts in raise/lower mode.</p> <p><b>Unit of measurement:</b> -</p> <p><b>Options:</b> STAND BUMPL</p>			

### 4.19.4. LO.rE - Defining transition from remote SP to local SP

Acronym	Scrolling message	Submenu	Attributes
LO.rE	REMOTE TO LOCAL TRANSITION TYPE	MODE	R W
<p>The parameter shows and sets controller behavior when switching from remote to local setpoint, and is significant only with F.SPr = SETP.</p> <p>With STAND, the setpoint switches to the value of the selected local SP or multiset, possibly with setpoint gradient (if set).</p> <p>With BUMPL, the remote SP value is memorized in the selected local SP or multiset.</p> <p><b>Unit of measurement:</b> -</p> <p><b>Options:</b> STAND BUMPL</p>			

## 4.19.5. On.OF - Enable software shutdown from keys

Acronym	Scrolling message	Submenu	Attributes
On.OF	SOFTWARE ON/OFF ENABLE	MODE	R W
<p>The parameter shows and determines whether controller software can be shut down using keys.            The software ON-OFF function is explained in detail in paragraph "5.8. Switching the software on/off" on page 152.            The function for starting up controller software with the F key always remains enabled.            In the case of the programmer, the software shutdown option at the end of the programme End=OFF is not affected by this parameter.            In the case of timers, the software shutdown option at the end of the count End=OFF is not affected by this parameter.</p> <p><b>Unit of measurement:</b> -</p> <p><b>Options:</b>           <b>ENABL</b> = Controller software shutdown with keys is enabled                              <b>DISAB</b> = Controller software shutdown with keys is disabled</p>			

## 4.19.6. MA.PL - Enabling manual power latch

Acronym	Scrolling message	Submenu	Attributes
MA.PL	MANUAL POWER LATCH ENABLE	MODE	R W
<p>The parameter shows and sets enabling of memorization (in non-volatile memory) of the manual power value.</p> <p><b>Unit of measurement:</b> -</p> <p><b>Options:</b>           <b>LATCH</b> = Latch enabled                              <b>NO.LAT</b> = Latch disabled. After Power-on, Manual power value is reset</p>			

## 4.19.7. MAn.P - Enabling change of manual power value

Acronym	Scrolling message	Submenu	Attributes
MAn.P	MANUAL POWER MODIFY ENABLE	MODE	R W
<p>The parameter shows and sets enabling of change of the manual power value.</p> <p><b>Unit of measurement:</b> -</p> <p><b>Options:</b>           <b>MODIF</b> = Change allowed                              <b>NO.MOD</b> = Change not allowed</p>			

## 4.19.8. dIG - Defining type of digital inputs

Acronym	Scrolling message	Submenu	Attributes
dIG	DIGITAL INPUT TYPE	MODE	R W
<p>The parameter shows and sets the type of digital inputs.</p> <p><b>Unit of measurement:</b> -</p> <p><b>Options:</b>           <b>NPN</b> = NPN digital inputs or voltage-free contact                              <b>PNP</b> = PNP digital inputs</p>			

## 4.19.9. S.PROG - Enable Simplified Programmer mode

Acronym	Scrolling message	Submenu	Attributes
S.PROG	SIMPLIFIED PROGRAMMER MODE	MODE	R W
<p>This parameter shows and sets enabling of the editor set-up in the tools menu.</p> <p><b>Unit of measurement:</b> -</p> <p><b>Options:</b>           <b>OFF</b> = Simplified Programmer Mode disabled                              <b>On</b> = Simplified Programmer Mode enabled</p>			

## 4. CONFIGURATION

### 4.19.10. EN.EDI - Enable MENU CONFIGURATION

Acronym	Scrolling message	Submenu	Attributes
EN.EDI	ENABLE EDITOR CONFIGURATOR	MODE	R W
<p>This parameter shows and sets enabling of the editor set-up in the tools menu.</p> <p><b>Unit of measurement:</b> -</p> <p><b>Options:</b>           <b>OFF</b>    = MENU set-up disabled                   <b>On</b>       = Simplified MENU set-up enabled</p>			

### 4.19.11. ALRM.N - Number of alarms enabled

Acronym	Scrolling message	Submenu	Attributes
ALRM.N	NUM OF ENABLE ALARMS	MODE	R W
<p>The parameter shows and sets the number of alarms enabled. No alarm is enabled if the parameter equals "0".</p> <p><b>Unit of measurement:</b> Number</p> <p><b>Options:</b>           <b>0...4</b></p>			

### 4.19.12. tMEr - Enabling Timer function

Acronym	Scrolling message	Submenu	Attributes
tMEr	TIMER ENABLE	MODE	R W
<p>The parameter shows and sets enabling of the Timer function. The Timer function is explained in detail in paragraph "5.11. Timer" on page "5.11. Timer" on page 155.</p> <p><b>Unit of measurement:</b> -</p> <p><b>Options:</b>           <b>OFF</b>       = Timer disabled                   <b>ON.SEC</b> = Timer enabled with time base Seconds                   <b>ON.MIN</b> = Timer enabled with time base Minutes</p>			

### 4.19.13. MUL.SP - Enabling Multiset function

Acronym	Scrolling message	Submenu	Attributes
MUL.SP	MULTISET ENABLE	MODE	R W
<p>The parameter shows and sets enabling of the Multiset function. The MULTISET function is explained in detail in paragraph "5.12. Multiset, setpoint gradient" on page "5.12. Multiset, setpoint gradient" on page 157.</p> <p><b>Unit of measurement:</b> -</p> <p><b>Options:</b>           <b>OFF</b>       = Multiset disabled                   <b>On</b>        = Multiset enabled</p>			

## 4.19.14. SP.REM - Enabling the remote setpoint

Acronym	Scrolling message	Submenu	Attributes
SP.REM	REMOTE SP ENABLE	MODE	R W
<p>The parameter shows and sets enabling and the type of the remote set point.            It is enabled in sub-menu I.SPR, parameter F.SP<sub>r</sub> = SETP            The remote set point must also be set as a function of the remote input F.SP<sub>r</sub> = SETP.            Remote mode is enabled from the keys, digital inputs, serial line or as Function Block output by setting the LO-RE option.</p> <p><b>Unit of measurement:</b> -</p> <p><b>Options:</b></p> <p><b>OFF</b> = Remote setpoint disabled  <b>On</b> = Remote setpoint enabled from analog input  <b>SEr</b> = Remote setpoint enabled from serial</p>			

## 4.19.15. SP.r.t - Defining absolute or deviation remote setpoint

Acronym	Scrolling message	Submenu	Attributes
SP.r.t	REMOTE SP TYPE	MODE	R W
<p>The parameter shows and defines the setpoint as absolute or deviation.            The absolute remote setpoint replaces the local setpoint in the control.            The deviation remote setpoint is added algebraically to the local setpoint in the control.            The parameter appears only if the parameter SP.REM is different from OFF.</p> <p><b>Unit of measurement:</b> -</p> <p><b>Options:</b></p> <p><b>ABSLT</b> = Absolute remote setpoint  <b>RELAT</b> = Deviation remote setpoint</p>			

## 4.19.16. PROGR - Enabling the setpoint programmer

Acronym	Scrolling message	Submenu	Attributes
PROGR	PROGRAMMER ENABLE	MODE	R W
<p>The parameter shows and sets enabling of the setpoint programmer for P or PV models.</p> <p><b>Unit of measurement:</b> -</p> <p><b>Options:</b></p> <p><b>OFF</b> = Setpoint programmer disabled  <b>On</b> = Setpoint programmer enabled</p>			

## 4.19.17. t.Pro - Setting the programmer base time

Acronym	Scrolling message	Submenu	Attributes
t.Pro	PROGRAMMER BASE TIME DEFINITION	MODE	R W
<p>The parameter shows and sets the base time used by the programmer.            The parameter appears if the parameter PROGR = On.</p> <p><b>Unit of measurement:</b> -</p> <p><b>Options:</b></p> <p><b>HH.MM</b> = Base time calculated in hours:minutes  <b>MM.SS</b> = Base time calculated in minutes:seconds</p>			

## 4. CONFIGURATION

### 4.19.18. ENERG - Enabling the energy counter function

Acronym	Scrolling message	Submenu	Attributes
ENERG	ENERGY COUNTER ENABLE	MODE	R W
<p>The parameter shows and sets enabling of the energy counter function. The Energy Counter function is explained in detail in paragraph "5.15. Energy Counter" on page "5.15. Energy counter" on page 163.</p> <p><b>Unit of measurement:</b> -</p> <p><b>Options:</b>           <b>OFF</b>    = Energy counter disabled                   <b>On</b>        = Energy counter enabled</p>			

### 4.19.19. T.SAMP - Main input sample time

Acronym	Scrolling message	Submenu	Attributes
T.SAMP	MAIN INPUT SAMPLE TIME	MODE	R W
<p>The parameter shows and sets the main input sample time.</p> <p><b>Unit of measurement:</b>    Milliseconds</p> <p><b>Options:</b>               <b>60</b>                               <b>120</b></p>			

### 4.19.20. FREQZ - Defining power line frequency

Acronym	Scrolling message	Submenu	Attributes
FREQZ	LINE FREQUENCY	MODE	R W
<p>The parameter shows and sets the power line frequency</p> <p><b>Unit of measurement:</b>    Hz</p> <p><b>Options:</b>               <b>50</b>                               <b>60</b></p>			

### 4.20. TIMER Submenu – Configuring timer parameters

Acronym	Scrolling message	Password	Description
TIMER	TIMER MANAGER	Level 2	Lets you configure the timer parameters.  The submenu appears only if the Timer function was enabled on the MODE submenu.

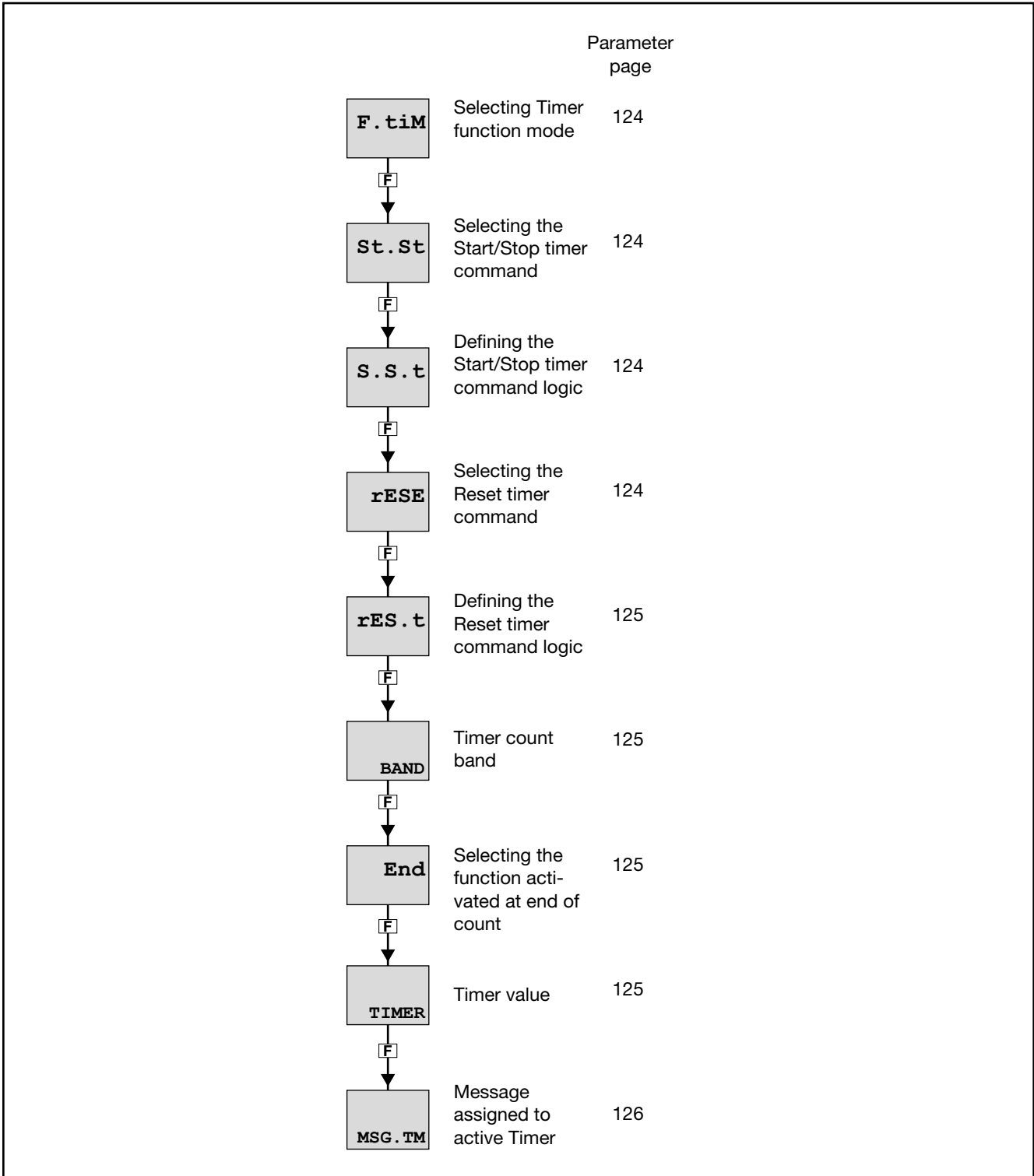

## 4. CONFIGURATION

### 4.20.1. F.tiM - Selecting Timer function mode

Acronym	Scrolling message	Submenu	Attributes
F.tiM	TIMER FUNCTION	TIMER	R W
<p>The parameter shows and sets the timer function mode. The Timer function is explained in detail in paragraph “5.11. Timer” on page “5.11. Timer” on page 155.</p> <p><b>Unit of measurement:</b> -</p> <p><b>Options:</b>           <b>ST.STP</b> = Start/Stop Timer                           <b>STABL</b> = Stabilization Timer                           <b>SWITC</b> = Power-on Timer</p>			

### 4.20.2. St.St - Selecting the Start/Stop timer command

Acronym	Scrolling message	Submenu	Attributes
St.St	TIMER START STOP	TIMER	R W
<p>The parameter shows and sets the “object” that commands timer Start/Stop.</p> <p><b>Unit of measurement:</b> -</p> <p><b>Options:</b>           <b>IN.DIG</b> = From digital input                           <b>ALRM1</b> = From alarm 1                           <b>ALRM2</b> = From alarm 2                           <b>ALRM3</b> = From alarm 3                           <b>ALRM4</b> = From alarm 4                           <b>AL.HB</b> = From HB alarm                           <b>SERIA</b> = From serial</p>			

### 4.20.3. S.S.t - Defining the Start/Stop timer command logic

Acronym	Scrolling message	Submenu	Attributes
S.S.t	LOGIC TYPE OF TIMER START/STOP	TIMER	R W
<p>The parameter shows and sets the type of logic used to command timer Start/Stop. With positive logic, timer start corresponds to “object” active if IN.DIG input active. With negative logic, timer start corresponds to “object” inactive if IN.DIG input inactive.</p> <p><b>Unit of measurement:</b> -</p> <p><b>Options:</b>           <b>POSIT</b> = Positive logic                           <b>NEGAT</b> = Negative logic</p>			

### 4.20.4. rESE - Selecting the Reset timer command

Acronym	Scrolling message	Submenu	Attributes
rESE	TIMER RESET	TIMER	R W
<p>The parameter shows and sets the “object” that commands Reset of the timer.</p> <p><b>Unit of measurement:</b> -</p> <p><b>Options:</b>           <b>AUT.RS</b> = For autoreset with timer in Stop                           <b>IN.DIG</b> = From digital input with T.RST function                           <b>ALRM1</b> = From alarm 1                           <b>ALRM2</b> = From alarm 2                           <b>ALRM3</b> = From alarm 3                           <b>ALRM4</b> = From alarm 4                           <b>AL.HB</b> = From HB alarm                           <b>SERIA</b> = From serial</p>			

## 4.20.5. rES.t - Defining the timer reset command logic

Acronym	Scrolling message	Submenu	Attributes
rES.t	LOGIC TYPE OF TIMER RESET	TIMER	R W
<p>The parameter shows and sets the type of logic used to command the timer reset.            With positive logic, the timer is reset with “object” active.            With negative logic, the timer is reset with “object” inactive.</p> <p><b>Unit of measurement:</b> -</p> <p><b>Options:</b>           <b>POSIT</b> = Positive logic                              <b>NEGAT</b> = Negative logic</p>			

## 4.20.6. BAND - Band for timer count

Acronym	Scrolling message	Submenu	Attributes
BAND	SYMM SP BAND WHERE TIMER IS ACTIVE	TIMER	R W
<p>The parameter shows and sets the symmetrical band around the setpoint within which the timer count is on.            The parameter appears if the parameter F.tiM = STABL            If the parameter equals “0.0” the count is immediate as soon as the setpoint is reached for the first time.</p> <p><b>Unit of measurement:</b> % of full scale of main input</p> <p><b>Options:</b>           <b>0.0...25.0</b></p>			

## 4.20.7. End - Selecting the function activated at end of count

Acronym	Scrolling message	Submenu	Attributes
End	FUNCTION WHERE TIMER IS OVER	TIMER	R W
<p>The parameter shows and sets the function that is activated when the timer ends the count.            The parameter appears if the parameter F.tiM = ST.STP or STABL.</p> <p><b>Unit of measurement:</b> -</p> <p><b>Options:</b>           <b>NONE</b> = None: control continues with actual setpoint                              <b>OFF</b> = Software off                              if the Multiset function is enabled:                              <b>SP1-2</b> = Change setpoint SP1/SP2</p>			

## 4.20.8. TIMER - Timer value

Acronym	Scrolling message	Submenu	Attributes
TIMER	ACTUAL TIME	TIMER	R W
<p>The parameter shows and sets the timer value.</p> <p><b>Unit of measurement:</b> Minutes or Seconds according to the selection set in the MODE submenu, parameter tMER</p> <p><b>Options:</b>           <b>0...9999</b></p>			

## 4. CONFIGURATION

---

### 4.20.9. MSG.TM - Selecting the message assigned to the active count

Acronym	Scrolling message	Submenu	Attributes
MSG.TM	MSG NUMBER WHEN TIMER OVER	TIMER	R W
<p>The parameter shows and sets the number of the message assigned to the active timer count, i.e., the scrolling message shown on the display.</p> <p>For more information on scrolling messages, see paragraph “3.1.2.2. Scrolling messages” on page 34.</p> <p>If the parameter is set to “0” no message will be displayed during the active timer count</p> <p><b>Unit of measurement:</b> Message number</p> <p><b>Options:</b> 0...25</p>			

## 4.21. ENERG Submenu - Configuring energy counter parameters

Acronym	Scrolling message	Password	Description
ENERG	ENERGY COUNTER MANAGER	Level 2	Lets you configure the energy counter parameters.  The submenu appears if the energy counter function was enabled on the MODE submenu.

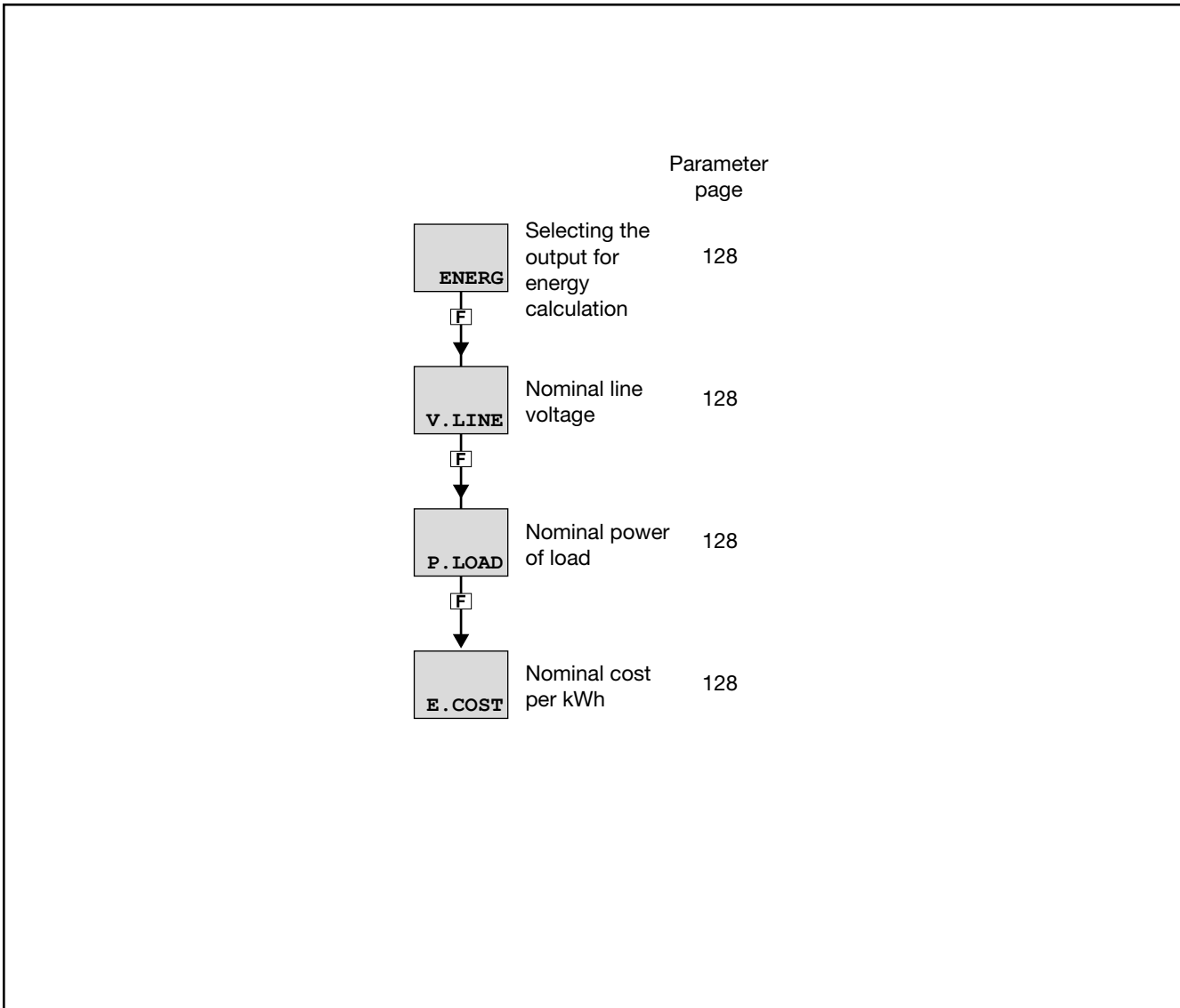

## 4. CONFIGURATION

### 4.21.1. ENERG - Selecting the output for energy calculation

Acronym	Scrolling message	Submenu	Attributes
ENERG	ENERGY COUNTER ENABLE	ENERG	R W
<p>The parameter shows and sets the output to be used for the energy calculation. The controller totalizes the time during which the output is active and uses it for the energy calculation.</p> <p><b>Unit of measurement:</b> -</p> <p><b>Options:</b>            <b>OUt1</b> = Output 1                           <b>OUt2</b> = Output 2                           <b>OUt3</b> = Output 3                           <b>OUt4</b> = Output 4</p>			

### 4.21.2. V.LINE - Nominal line voltage

Acronym	Scrolling message	Submenu	Attributes
V.LINE	NOMINAL VOLTAGE	ENERG	R W
<p>The parameter shows and sets the nominal line voltage to be used for the energy calculation.</p> <p><b>Unit of measurement:</b> V</p> <p><b>Options:</b>            0...999</p>			

### 4.21.3. P.LOAD - Nominal power of load

Acronym	Scrolling message	Submenu	Attributes
P.LOAD	LOAD NOMINAL POWER	ENERG	R W
<p>The parameter shows and sets the nominal power of the load controlled by the output. If the parameter is set to "0.00" the data used is the RMS current measured with the CT1 or CT1 + CT2 current transformer (optional).</p> <p><b>Unit of measurement:</b> kW</p> <p><b>Options:</b>            0.00...99.99</p>			

### 4.21.4. E.COST - Nominal cost per kWh

Acronym	Scrolling message	Submenu	Attributes
E.COST	ENERGY COST / KWH	ENERG	R W
<p>The parameter shows and sets the nominal cost of energy per kWh.</p> <p><b>Unit of measurement:</b> Number</p> <p><b>Options:</b>            0.000...9.999</p>			

4.22. SERIA Submenu – Configuring serial communication

Acronym	Scrolling message	Password	Description
SERIA	SERIAL COMMUNICATION CONFIG	Level 2	Lets you configure serial communication

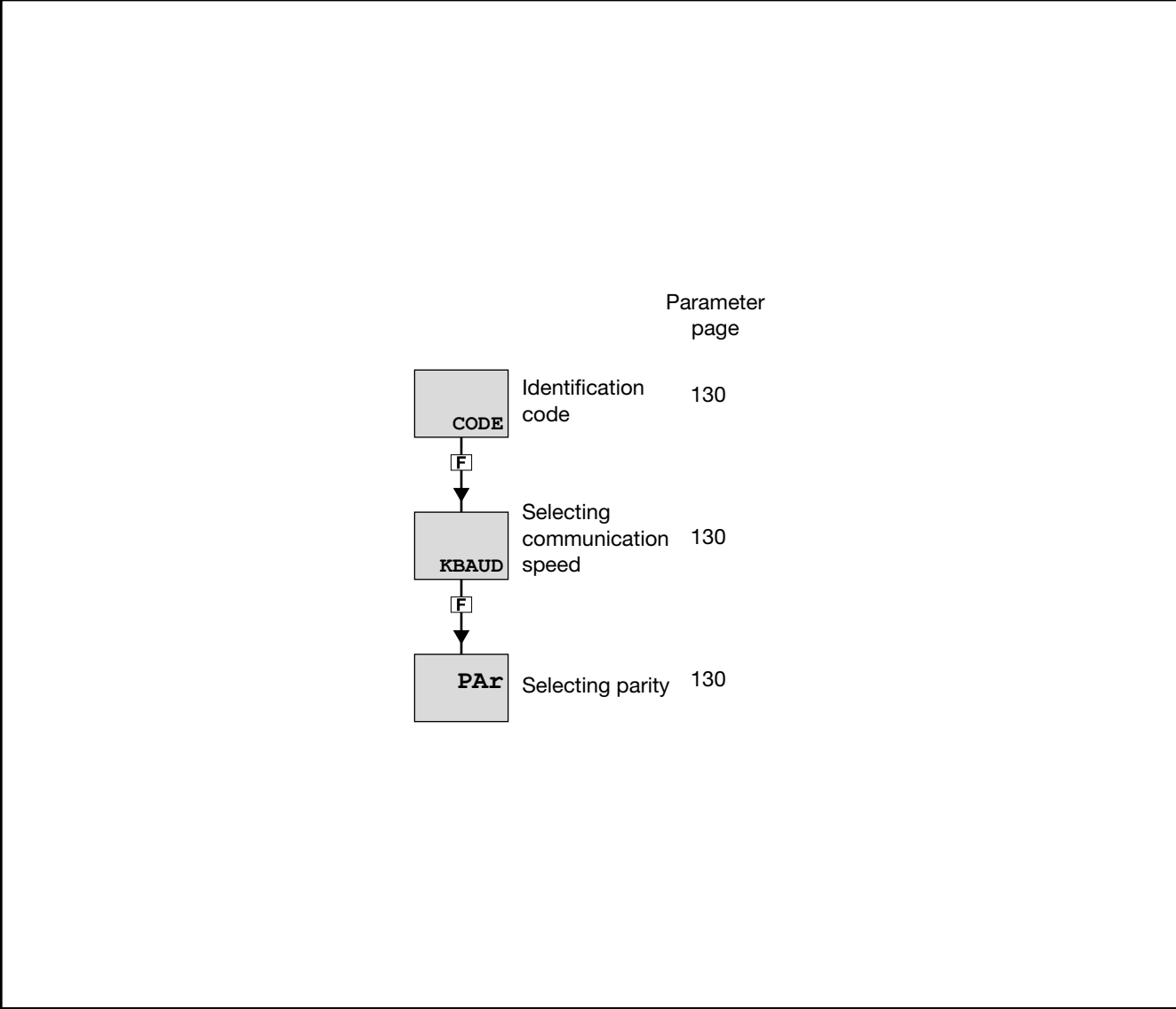

## 4. CONFIGURATION

### 4.22.1. CODE - Identification code

Acronym	Scrolling message	Submenu	Attributes
CODE	INSTRUMENT ID CODE FOR SERIAL COMM	SERIA	R W
The parameter shows and sets the identifying code of the controller in a Modbus serial network.			
<i>Unit of measurement:</i> Number			
<i>Options:</i> 1...247			

### 4.22.2. KBAUD - Selecting communication speed

Acronym	Scrolling message	Submenu	Attributes
KBAUD	COMMUNICATION SPEED	SERIA	R W
The parameter shows and sets the communication speed for the serial port.			
<i>Unit of measurement:</i> kbaud			
<i>Options:</i>			
	1.2	= 1200 baud	
	2.4	= 2400 baud	
	4.8	= 4800 baud	
	9.6	= 9600 baud	
	19.2	= 19200 baud	
	38.4	= 38400 baud	
	57.6	= 57600 baud	
	115.2	= 115200 baud	

### 4.22.3. PAr - Selecting parity

Acronym	Scrolling message	Submenu	Attributes
PAr	PARITY	SERIA	R W
The parameter shows and sets the parity used in serial communication.			
<i>Unit of measurement:</i> -			
<i>Options:</i>			
	NONE	= No parity	
	ODD	= Odd parity	
	EVEN	= Even parity	

### 4.23. HMI Submenu – Configuring the display and keypad

Acronym	Scrolling message	Password	Description
HMI	DISPLAY AND KEYBOARD	Level 2	Lets you configure the controller’s display and keys

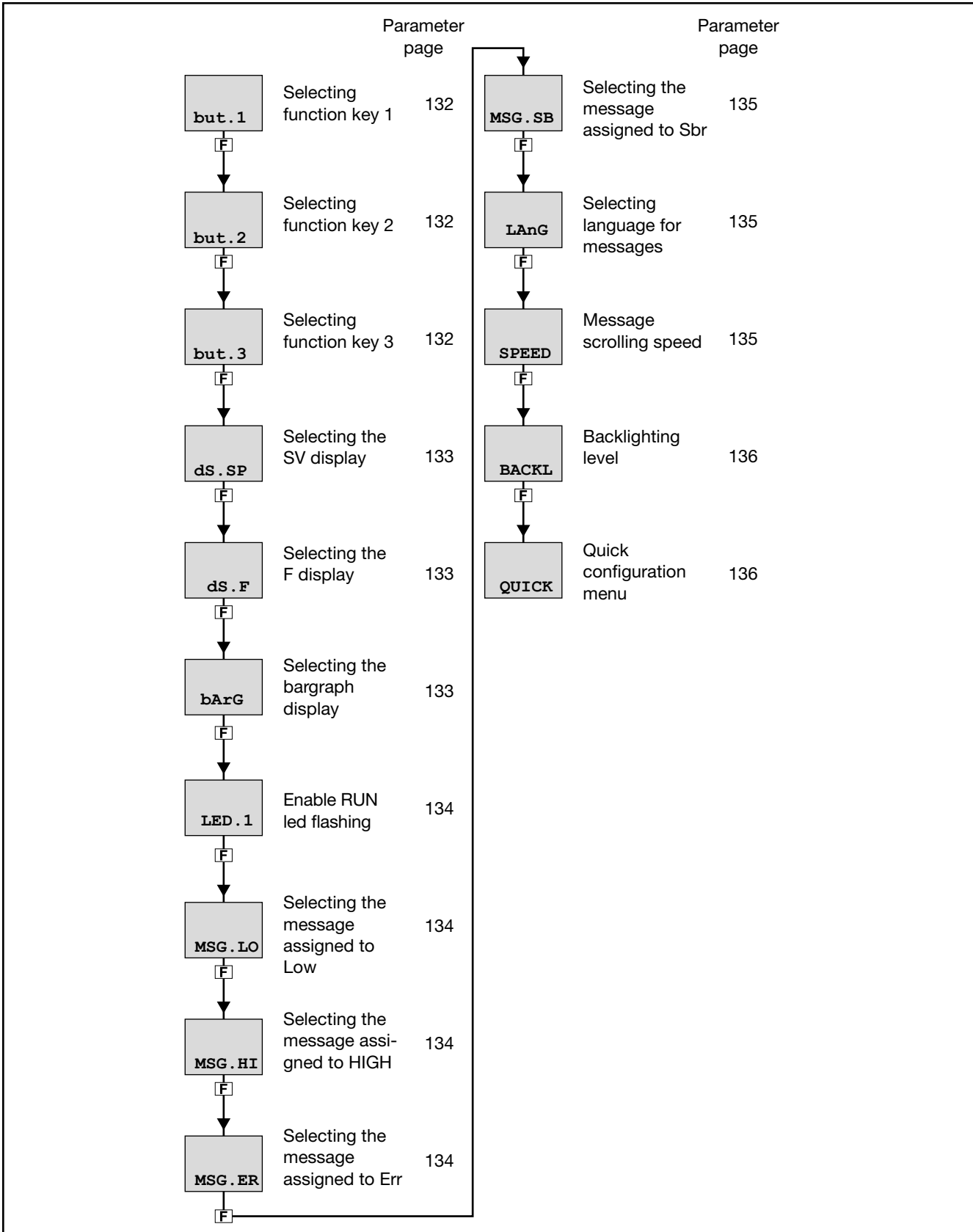

## 4. CONFIGURATION

### 4.23.1. but.1 - Selecting function key 1

Acronym	Scrolling message	Submenu	Attributes
but.1	KEY FUNCTION	HMI	R W
<p>The parameter shows and sets the function assigned to key 1 () of the controller.</p> <p><b>Unit of measurement:</b> -</p> <p><b>Options:</b></p> <ul style="list-style-type: none"> <li><b>NONE</b> = No function assigned</li> <li><b>AU-MA</b> = Automatic-Manual control</li> <li><b>LO-RE</b> = Local-remote setpoint mode</li> <li><b>HOLD</b> = Hold main input value</li> <li><b>AL.ACK</b> = Reset alarm latches</li> <li><b>S.TUNE</b> = Activate Self-Tuning</li> <li><b>A.TUNE</b> = Activate Auto-Tuning</li> <li><b>OUT.S.R</b> = Set/reset outputs set with BUT.SR function</li> <li><b>INT.RS</b> = General reset</li> <li><b>CAL.HB</b> = Calibrate HB alarm</li> <li><i>if the Multiset function is enabled:</i></li> <li><b>SP.SEL</b> = Select setpoint SETP1...SETP2</li> <li><i>if enabled Options Logics</i></li> <li><b>FB.IN</b> = Input Function Blocks</li> </ul>			

### 4.23.2. but.2 - Selecting function key 2

Acronym	Scrolling message	Submenu	Attributes
but.2	KEY FUNCTION	HMI	R W
<p>The parameter shows and sets the function assigned to key 2 () of the 4140 controller.</p> <p><b>Unit of measurement:</b> -</p> <p><b>Options:</b> As per <b>but.1</b></p>			

### 4.23.3. but.3 - Selecting function key 3

Acronym	Scrolling message	Submenu	Attributes
but.3	KEY FUNCTION	HMI	R W
<p>The parameter shows and sets the function assigned to key 3 () of the 4140 controller.</p> <p><b>Unit of measurement:</b> -</p> <p><b>Options:</b> As per <b>but.1</b></p>			

## 4.23.4. dS.SP - Selecting the SV display

Acronym	Scrolling message	Submenu	Attributes
dS.SP	SV DISPLAY FUNCTION	HMI	R W
<p>The parameter shows and sets the display assigned to the SV display.</p> <p><b>Unit of measurement:</b> -</p> <p><b>Options:</b></p> <p><b>NONE</b> = NONE = Display off  <b>SETP</b> = Local setpoint / manual power or active setpoint (read only), in case of Multiset function  <b>SSP</b> = Active setpoint (read only)  <b>IN.SPR</b> = Remote setpoint input  <b>OUT.PW</b> = Power control output  <b>SP-PV</b> = Deviation  SP-PV   <b>HEAT</b> = Heating power output with 0...100% control  <b>COOL</b> = Cooling power output with 0...100% control  <b>HE+CO</b> = Power control output -100...100% (positive for heating, negative for cooling)  <b>CURR1</b> = Current input CT1  <b>CURR2</b> = Current input CT2</p> <p><i>if the ENERG function is enabled:</i>  <b>CURR</b> = Load current  <b>OUT.KW</b> = Power on load  <b>ENERG</b> = Energy transferred to load</p> <p><i>if the Timer function is enabled:</i>  <b>TIM.RE</b> = Remaining timer value  <b>TIM.EL</b> = Timer value lapsed</p> <p><i>if controller model with valve control:</i>  <b>V.POSI</b> = Valve position</p> <p><i>if controller model with programmer:</i>  <b>P.TIME</b> = Current ramp time or retention step execution</p>			

## 4.23.5. dS.F - Selecting the F display

Acronym	Scrolling message	Submenu	Attributes
dS.F	F DISPLAY FUNCTION	HMI	R W
<p>The parameter shows and sets the display assigned to the F display.  The parameter appears only if the controller is 4140.</p> <p><b>Unit of measurement:</b> -</p> <p><b>Options:</b> Same as <b>dS.SP</b></p> <p><b>note:</b> if dS.SP = SETP and dS.F = OUT.PW  or dS.SP = OUT.PW and dS.F = SETP in manual operation  gradient GRAD.0 = 0: OUT.PW become MAN.PW  gradient GRAD.0 &lt;&gt; 0: SETP become MAN.PW  MAN.PW be changed via up / down if MAN.P = CHANGE</p>			

## 4.23.6. bArG - Selecting the bargraph display

Acronym	Scrolling message	Submenu	Attributes
bArG	BARGRAPH FUNCTION	HMI	R W
<p>The parameter shows and sets the display assigned to the bargraph.  The parameter appears only if the controller is 4140.</p> <p><b>Unit of measurement:</b> -</p> <p><b>Options:</b> Same as <b>dS.SP</b></p>			

## 4. CONFIGURATION

### 4.23.7. LED.1 – Enable RUN led flashing

Acronym	Scrolling message	Submenu	Attributes
LED.1	ENABLE OF RUN LED BLINKING	HMI	R W

The parameter enables and disabled RUN led flashing.

**Unit of measurement:** -

### 4.23.8. MSG.LO - Selecting the message assigned to Low

Acronym	Scrolling message	Submenu	Attributes
MSG.LO	NUM SCROLLING MSG WHEN MAIN INPUT IS LOW ERR	HMI	R W

The parameter shows and sets the number of the message assigned to Low (process variable < minimum scale limit), i.e., the scrolling message shown on the display.  
For more information on scrolling messages, see paragraph “3.1.2.2. Scrolling messages” on page “3.1.2.2. Scrolling messages” on page 34.  
If the parameter is set to “0” no message will be displayed for Lou.

As default, MSG.LO is assigned the message “1” (for LANG1 corresponds to “PROCESS VALUE UNDER LOW LIMIT”, for LANG2 corresponds to “VALORE DEL PROCESSO SOTTO IL LIMITE INFERIORE”).

**Unit of measurement:** Message number

**Options:** 0...25

### 4.23.9. MSG.HI - Selecting the message assigned to HIGH

Acronym	Scrolling message	Submenu	Attributes
MSG.HI	NUM SCROLLING MSG WHEN MAIN INPUT IS HI ERR	HMI	R W

The parameter shows and sets the number of the message assigned to HIGH (process variable > maximum scale limit), i.e., the scrolling message shown on the display.  
For more information on scrolling messages, see paragraph “3.1.2.2. Scrolling messages” on page 34.  
If the parameter is set to “0” no message will be displayed for Hi GH.

As default, MSG.HI is assigned the message “2” (for LANG1 corresponds to “PROCESS VALUE OVER HIGH LIMIT”, for LANG2 corresponds to “VALORE DEL PROCESSO OLTRE IL LIMITE MASSIMO”).

**Unit of measurement:** Message number

**Options:** 0...25

### 4.23.10. MSG.ER - Selecting the message assigned to Err

Acronym	Scrolling message	Submenu	Attributes
MSG.ER	NUM SCROLLING MSG WHEN MAIN INPUT IS ERR ERR	HMI	R W

The parameter shows and sets the number of the message assigned to Err (Pt100 in short circuit or input values below minimum limit), i.e., the scrolling message shown on the display.  
 For more information on scrolling messages, see paragraph “3.1.2.2. Scrolling messages” on page 34.  
 If the parameter is set to “0” no message will be displayed for Err.

As default, MSG.ER is assigned the message “3” (for LANG1 corresponds to “INPUT SENSOR FAIL CONNECTION”, for LANG2 corresponds to “ERRATA CONNESSIONE SONDA”).

**Unit of measurement:** Message number

**Options:** 0...25

#### 4.23.11. MSG.SB - Selecting the message assigned to Sbr

Acronym	Scrolling message	Submenu	Attributes
MSG.SB	NUM SCROLLING MSG WHEN MAIN IN IS SB ERR	HMI	R W
<p>The parameter shows and sets the number of the message assigned to Err (sensor break in short circuit or input values above maximum limit), i.e., the scrolling message shown on the display.            For more information on scrolling messages, see paragraph “3.1.2.2. Scrolling messages” on page 34.            If the parameter is set to “0” no message will be displayed for Sbr.</p> <p>As default, MSG.SB is assigned the message “4” (for LANG1 corresponds to “SENSOR BROKEN”, for LANG2 corresponds to “SONDA APERTA”).</p> <p><b>Unit of measurement:</b> Message number</p> <p><b>Options:</b> 0...25</p>			

#### 4.23.12. LAnG - Selecting language for messages

Acronym	Scrolling message	Submenu	Attributes
LAnG	MESSAGE LANGUAGE	HMI	R W
<p>The parameter shows and sets the language for the scrolling messages.</p> <p><b>Unit of measurement:</b> -</p> <p><b>Options:</b>       <b>LANG1</b> = Language 1 (English)                          <b>LANG2</b> = Language 2 (Italian)                          <b>LANG3</b> = Language 3</p>			

#### 4.23.13. SPEED - Message scrolling speed

Acronym	Scrolling message	Submenu	Attributes
SPEED	SCROLLING MESSAGE SPEED	HMI	R W
<p>The parameter shows and sets the message scrolling speed.            “1” corresponds to maximum scrolling speed, “10” to minimum speed.            With “0” the message does not scroll and the display shows first 5 characters (on model 6140) or the first 7 characters (on model 4140).</p> <p><b>Unit of measurement:</b> -</p> <p><b>Options:</b>       <b>0...10</b> (default = 3)</p> <p><b>Note:</b>           Messages with the description of the parameters always flow at a constant speed.            NOT are subjected parameter setting SPEED</p>			

## 4. CONFIGURATION

### 4.23.14. BACKL - Backlighting level

Acronym	Scrolling message	Submenu	Attributes
BACKL	BACKLIGHT LEVEL	HMI	R W
<p>The parameter shows and sets the backlight level on the display (when the controller is on) 10 seconds after the last key has been pressed. With "0," the backlight does not switch off, but goes to the minimum useful level for reading the display. The backlight goes to maximum level when any key is pressed.</p> <p><b>Unit of measurement:</b> -</p> <p><b>Options:</b>           <b>0...10</b> (default = 8)</p>			

### 4.23.15. QUICK - Quick configuration menu

Acronym	Scrolling message	Submenu	Attributes
QUICK	QUICK CONFIG ENABLE	HMI	R W
<p>The parameter shows and sets enabling of the quick configuration menu.</p> <p><b>Unit of measurement:</b> -</p> <p><b>Options:</b>           <b>OFF</b>    = Quick configuration menu is not displayed                   <b>On</b>        = Quick configuration menu is displayed</p>			

4.24. LINRZ Submenu – Configuring custom linearization

Acronym	Scrolling message	Password	Description
LINRZ	CUSTOM LINEARIZATION CONFIG	Level 2	Lets you configure the parameters for custom linearization in 32 steps or 4 points.  The submenu is visible only if custom linearization was enabled in the configuration of the main input or of the setpoint input. You can set only one linearization, but it can be assigned to the main input, the setpoint input, or both.

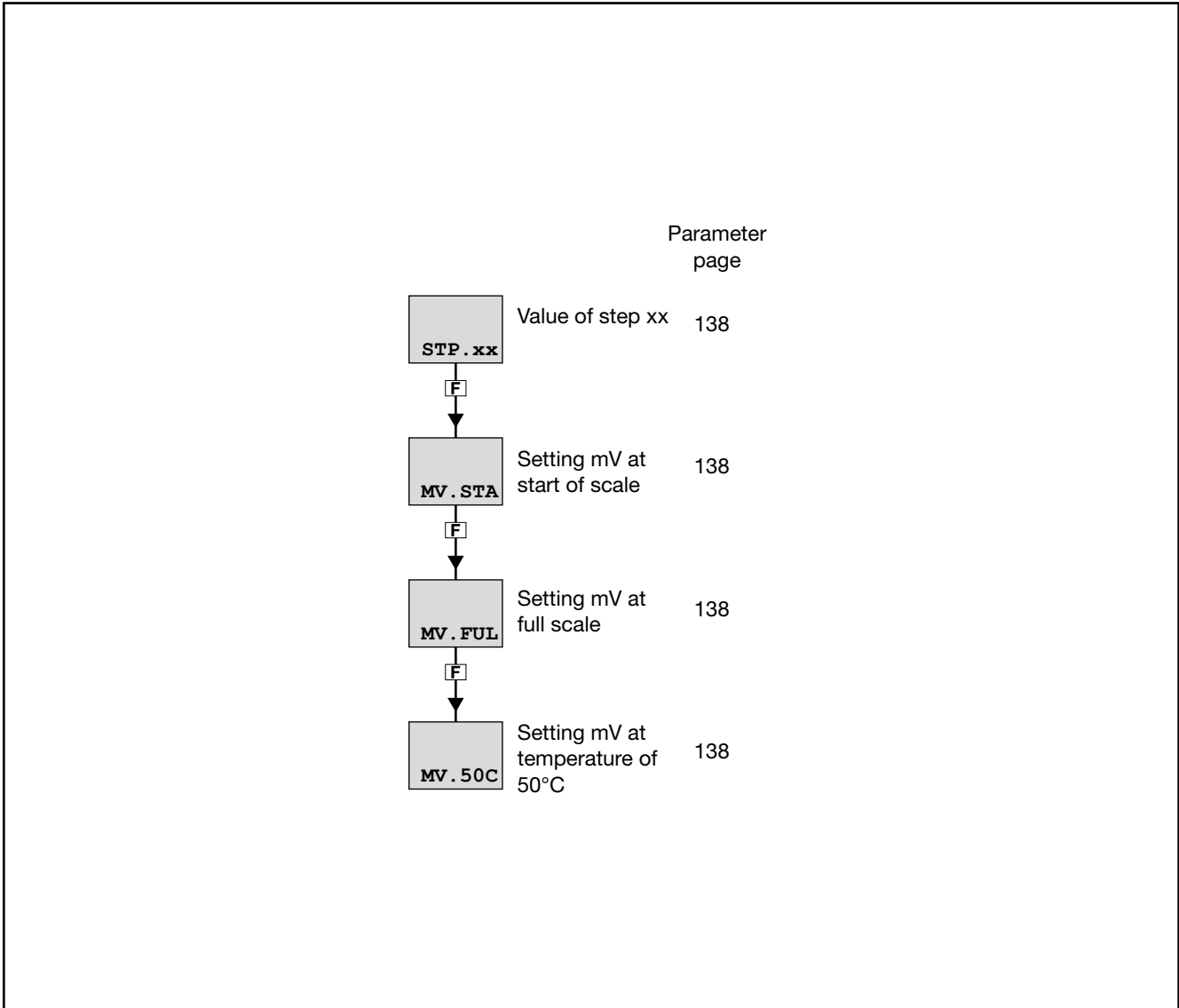

## 4. CONFIGURATION

### 4.24.1. STP.xx - Value of step xx

Acronym	Scrolling message	Submenu	Attributes
STP.xx	CUSTOM LINEARIZATION STEP	LINRZ	R W
<p>The parameter shows and sets the value of the various steps, with xx from 0 to 32. The start scale value goes in STP.00 and the full-scale value in STP.32.</p> <p>The value of the nth step corresponds to the input: <math>mV \text{ start scale} + n \cdot \Delta mV</math> con <math>\Delta mV = (mV \text{ full scale} - mV \text{ start scale})/32</math>.</p> <p><b>Unit of measurement:</b> Scale points</p> <p><b>Options:</b> -1999...9999</p>			

### 4.24.2. MV.STA - Setting mV at start of scale

Acronym	Scrolling message	Submenu	Attributes
MV.STA	MV START SCALE	LINRZ	R W
<p>The parameter shows and sets the value in millivolts at start of scale if the input is a thermocouple.</p> <p><b>Unit of measurement:</b> mV</p> <p><b>Options:</b> -19.99...99.99</p>			

### 4.24.3. MV.FUL - Setting mV at full scale

Acronym	Scrolling message	Submenu	Attributes
MV.FUL	MV FULL SCALE	LINRZ	R W
<p>The parameter shows and sets the value in millivolts at full scale if the input is a thermocouple.</p> <p><b>Unit of measurement:</b> mV</p> <p><b>Options:</b> MV.STA + 1...99.99</p>			

### 4.24.4. MV.50C - Setting mV at temperature of 50 °C

Acronym	Scrolling message	Submenu	Attributes
MV.50C	MV AT 50 °C	LINRZ	R W
<p>The parameter shows and sets the value in millivolts at 50°C if the input is a thermocouple.</p> <p><b>Unit of measurement:</b> mV</p> <p><b>Options:</b> -1.999...9.999</p>			

4.25. US.CAL Submenu – User calibrations

Acronym	Scrolling message	Password	Description
US.CAL	USER CALIBRATION MANAGER	Level 2	Lets the user calibrate the controller with regard to Custom main input, HB alarm setpoints, energy reset, and partial day count.

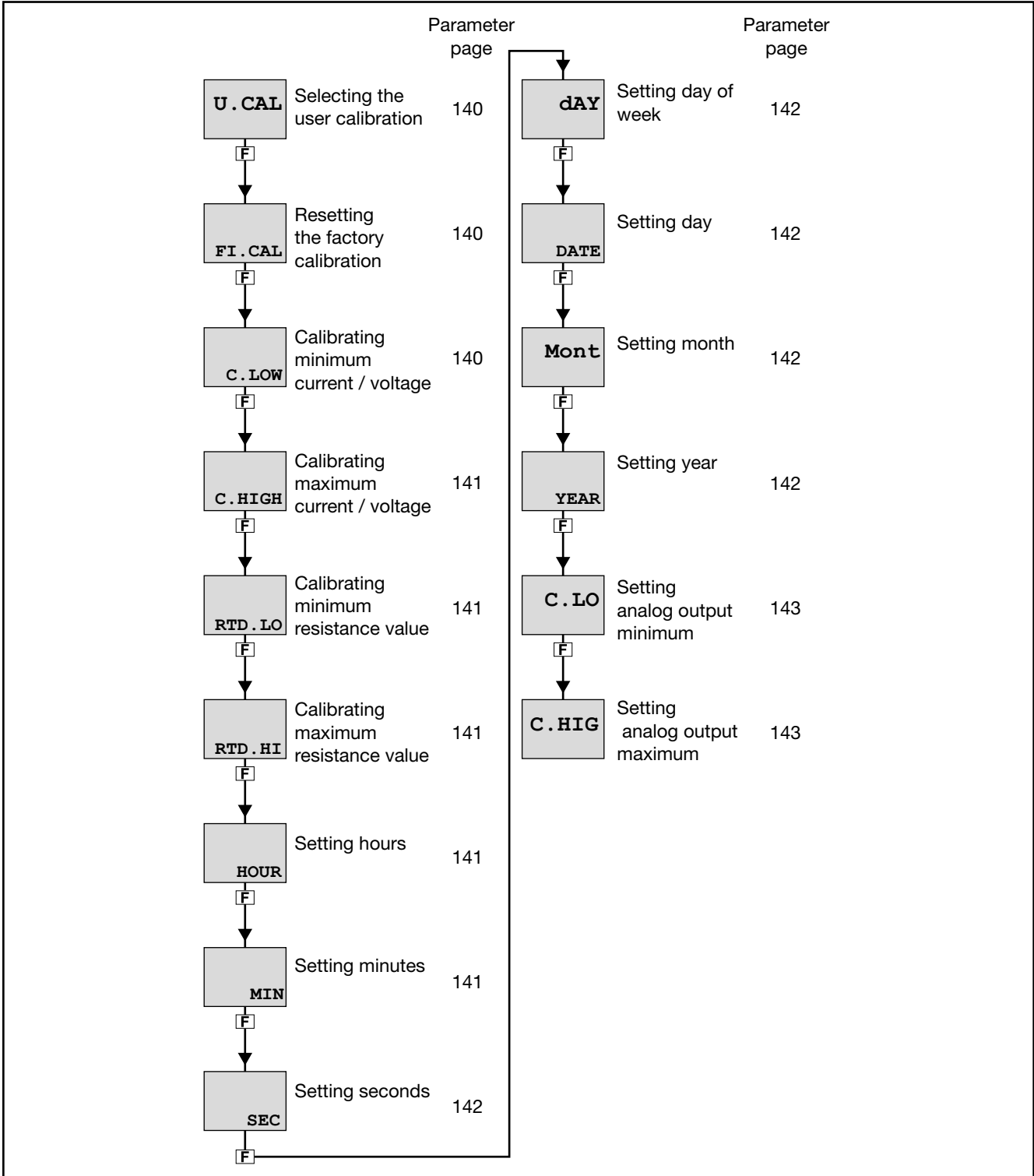

## 4. CONFIGURATION

### 4.25.1. U.CAL - Selecting the user calibration

Acronym	Scrolling message	Submenu	Attributes
U.CAL	USER CALIBRATION TYPE	US.CAL	R W
<p>The parameter shows and sets the parameter, input or output to which calibration will be applied.</p> <p><b>Unit of measurement:</b> -</p> <p><b>Options:</b></p> <p><b>NONE</b> = No calibration</p> <p><b>AL.HB</b> = HB calibration alarm. It is made up of 3 subsequent phases:            Phase 1 : OUTPUT SWITCH ON message, the output is enabled to 100% when the <b>[F]</b> key is pressed (set in the OUT parameter in sub-menu AL.HB) and then switch to phase 2.            Phase 2: CALIBRATION RUNNING message, the percent of the current value is calculated when the <b>[F]</b> key is pressed (set in parameter THR-PE in sub menu AL.HB) and saved in parameter LOW.ON, and then switch to phase 3.            Phase 3: END CALIBRATION message, press the <b>[F]</b> key to end calibration.</p> <p><b>RTC</b> = Real Time Clock setting            the data in the RTC at each power-on are initialized to:            HOUR = 0            MIN = 0            SEC = 0            dAY = MONDA      DATE = 1            Mont = JANUA            YEAR = 00</p> <p><b>ENERG</b> = Reset energy count (totalizer EN.KWH and time EN.TIM)</p> <p><b>P.DAYS</b> = Reset partial day count</p> <p><b>I.MAIN</b> = Calibration of custom main input (selected with parameter tyPE on I.MAIN menu)</p> <p><b>I.SPR</b> = Calibration of remote setpoint input (selected with parameter t.SPr on I.SPR menu)</p> <p><b>I.CT1</b> = CT1 input custom calibration</p> <p><b>I.CT2</b> = CT2 input custom calibration</p> <p><b>OUT.A1</b> = Calibration of custom retransmission output (selected with parameter t.o.A1 on OUT.AN menu)</p> <p><b>OUT.C</b> = Calibration of continuous output</p>			

### 4.25.2. FI.CAL - Resetting the factory calibration

Acronym	Scrolling message	Submenu	Attributes
FI.CAL	FACTORY CALIBRATION	US.CAL	R W
<p>The parameter shows and sets resetting of the factory calibration.            This operation can be done only for inputs and outputs, if U.CAL corresponds to I.MAIN, I.SPR, I.CT1, I.CT2, OUT.A1 or OUT.C.</p> <p><b>Unit of measurement:</b> -</p> <p><b>Options:</b></p> <p><b>no</b> = Keep user calibration</p> <p><b>YES</b> = Reset factory calibration</p>			

### 4.25.3. C.LOW - Calibrating minimum current / voltage

Acronym	Scrolling message	Submenu	Attributes
C.LOW		US.CAL	R W
<p>The parameter appears if you are calibrating a custom I.MAIN or I.SPR input in current or voltage.            To calibrate:</p> <ul style="list-style-type: none"> <li>• apply the current or voltage value corresponding to minimum scale value to the selected input;</li> <li>• press the <b>[F]</b> key to acquire the calibration value.</li> </ul> <p><b>Unit of measurement:</b> -</p> <p><b>Options:</b> -</p>			

## 4.25.4. C.HIGH - Calibrating maximum current / voltage

Acronym	Scrolling message	Submenu	Attributes
C.HIGH		US.CAL	R W
<p>The parameter appears if you are calibrating a custom I.MAIN or I.SPR input in current or voltage.            To calibrate:</p> <ul style="list-style-type: none"> <li>• apply the current or voltage value corresponding to maximum scale value to the selected input;</li> <li>• press the <b>[F]</b> key to acquire the calibration value.</li> </ul> <p><b>Unit of measurement:</b> -</p> <p><b>Options:</b> -</p>			

## 4.25.5. RTD.LO - Calibrating minimum resistance value

Acronym	Scrolling message	Submenu	Attributes
RTD.LO		US.CAL	R W
<p>The parameter appears if you are calibrating a custom I.MAIN RTD input.            To calibrate:</p> <ul style="list-style-type: none"> <li>• apply a resistance corresponding to minimum scale value to the main input (for example, 18.52 <math>\Omega</math> for Pt100 ;</li> <li>• press the <b>[F]</b> key to acquire the calibration value.</li> </ul> <p><b>Unit of measurement:</b> -</p> <p><b>Options:</b> -</p>			

## 4.25.6. RTD.HI - Calibrating maximum resistance value

Acronym	Scrolling message	Submenu	Attributes
RTD.HI		US.CAL	R W
<p>The parameter appears if you are calibrating a custom I.MAIN RTD input.            To calibrate:</p> <ul style="list-style-type: none"> <li>• apply a resistance corresponding to maximum scale value to the main input (for example, 390.48 <math>\Omega</math> for Pt100);</li> <li>• press the <b>[F]</b> key to acquire the calibration value.</li> </ul> <p><b>Unit of measurement:</b> -</p> <p><b>Options:</b> -</p>			

## 4.25.7. HOUR - Setting hours

Acronym	Scrolling message	Submenu	Attributes
HOUR		US.CAL	R W
<p>The parameter shows and sets the hours on the Real Time Clock, if U.CAL = RTC.</p> <p><b>Unit of measurement:</b> Hours</p> <p><b>Options:</b> 0...23</p>			

## 4.25.8. MIN - Setting minutes

Acronym	Scrolling message	Submenu	Attributes
MIN		US.CAL	R W
<p>The parameter shows and sets the minutes on the Real Time Clock, if U.CAL = RTC.</p> <p><b>Unit of measurement:</b> Minutes</p> <p><b>Options:</b> 0...59</p>			

## 4. CONFIGURATION

### 4.25.9. SEC - Setting seconds

Acronym	Scrolling message	Submenu	Attributes
SEC		US.CAL	R W
The parameter shows and sets the seconds on the Real Time Clock, if U.CAL = RTC. <b>Unit of measurement:</b> Seconds <b>Options:</b> 0...59			

### 4.25.10. dAY - Setting day of week

Acronym	Scrolling message	Submenu	Attributes
dAY		US.CAL	R W
The parameter shows and sets the day of the week on the Real Time Clock, if U.CAL = RTC. <b>Unit of measurement:</b> Day of week <b>Options:</b> MONDA...SUNDA			

### 4.25.11. DATE - Setting day

Acronym	Scrolling message	Submenu	Attributes
DATE		US.CAL	R W
The parameter shows and sets the day on the Real Time Clock, if U.CAL = RTC. <b>Unit of measurement:</b> Number of day <b>Options:</b> 1...31			

### 4.25.12. Mont - Setting month

Acronym	Scrolling message	Submenu	Attributes
Mont		US.CAL	R W
The parameter shows and sets the month on the Real Time Clock, if U.CAL = RTC. <b>Unit of measurement:</b> Month <b>Options:</b> JANUA...DECEN			

### 4.25.13. YEAR - Setting year

Acronym	Scrolling message	Submenu	Attributes
YEAR		US.CAL	R W
The parameter shows and sets the year on the Real Time Clock, if U.CAL = RTC. <b>Unit of measurement:</b> Year <b>Options:</b> 0...99			

## 4.25.14. C.LO - Setting analog output minimum

Acronym	Scrolling message	Submenu	Attributes
C.LO		US.CAL	R W
<p>The parameter shows and sets the minimum analog output value.            You can change the displayed value with the <math>\Delta</math> and <math>\nabla</math> keys.            To check the real voltage/current value on the output during calibration, measure it with a voltmeter/ammeter.</p> <p><b>Unit of measurement:</b> Converter points</p> <p><b>Options:</b> 0...65535</p>			

## 4.25.15. C.HIG - Setting analog output maximum

Acronym	Scrolling message	Submenu	Attributes
C.HIG		US.CAL	R W
<p>The parameter shows and sets the maximum analog output value.            You can change the displayed value with the <math>\Delta</math> and <math>\nabla</math> keys.            To check the real voltage/current value on the output during calibration, measure it with a voltmeter/ammeter.</p> <p><b>Unit of measurement:</b> Converter points</p> <p><b>Options:</b> 0...65535</p>			

## 4. CONFIGURATION

### 4.26. PASC0 - Setting level 0 password 0

Acronym	Scrolling message	Submenu	Attributes
PASC0	SET PASS0	Level 2	R W
<p>This parameter may be used to set the password to access User Menu parameters. Default code: 10.</p> <p><b>Unit of measurement:</b> Number</p> <p><b>Options:</b> 0...9999</p>			

### 4.27. PASC1 - Setting level 1 password 1

Acronym	Scrolling message	Submenu	Attributes
PASC1	SET PASS1	Level 2	R W
<p>This parameter may be used to set the password to access the level 1 configuration submenu and User Menu parameters.</p> <p><b>Unit of measurement:</b> Number</p> <p><b>Options:</b> 0...9999</p>			

### 4.28. PASC2 - Setting level 2 password 2

Acronym	Scrolling message	Submenu	Attributes
PASC2	SET PASS2	Level 2	R W
<p>The parameter lets you set the password for accessing level 2 configuration submenus.</p> <p><b>Unit of measurement:</b> Number</p> <p><b>Options:</b> 0...9999</p>			

### 4.29. FI.CFG - Entering the reset code

Acronym	Scrolling message	Submenu	Attributes
FI.CFG	ENTER DEFAULT CONFIGURATION PASS	Level 2	R W
<p>The parameter lets you set the code for resetting the controller to factory configuration, which will delete all changes made. Default code: 99.</p> <p>ATTENTION! After you have set code 99, when you press the <b>[F]</b> key the controller runs the Power-on procedure, as described in paragraph "3.2. Sequence at power-on."</p> <p><b>Unit of measurement:</b> Number</p> <p><b>Options:</b> 0...9999</p>			

## 5. EXAMPLES AND APPLICATION NOTES

### 5.1. Heat/cool control application

A 6140 controller (model 6140-D-R00-00000-1) controls a heating element via a solid-state relay connected to a logic output.

A TC sensor measures the temperature.

Each branch of the circuit is protected by a fuse.

The cooling or alarm relay is protected by a snubber.

The following diagram shows the various connections.

One switch can control more than one controller.

With Quick Configuration you set:

- sensor type (TC);
- unit of measurement of temperature (°C);
- the logic output function (HEAT);
- the relay output function (ALRM1);
- the setpoint, i.e. the temperature to be maintained (SETP);
- the temperature value that trips the alarm (ALRM1).

#### 5.1.1. Connection diagram

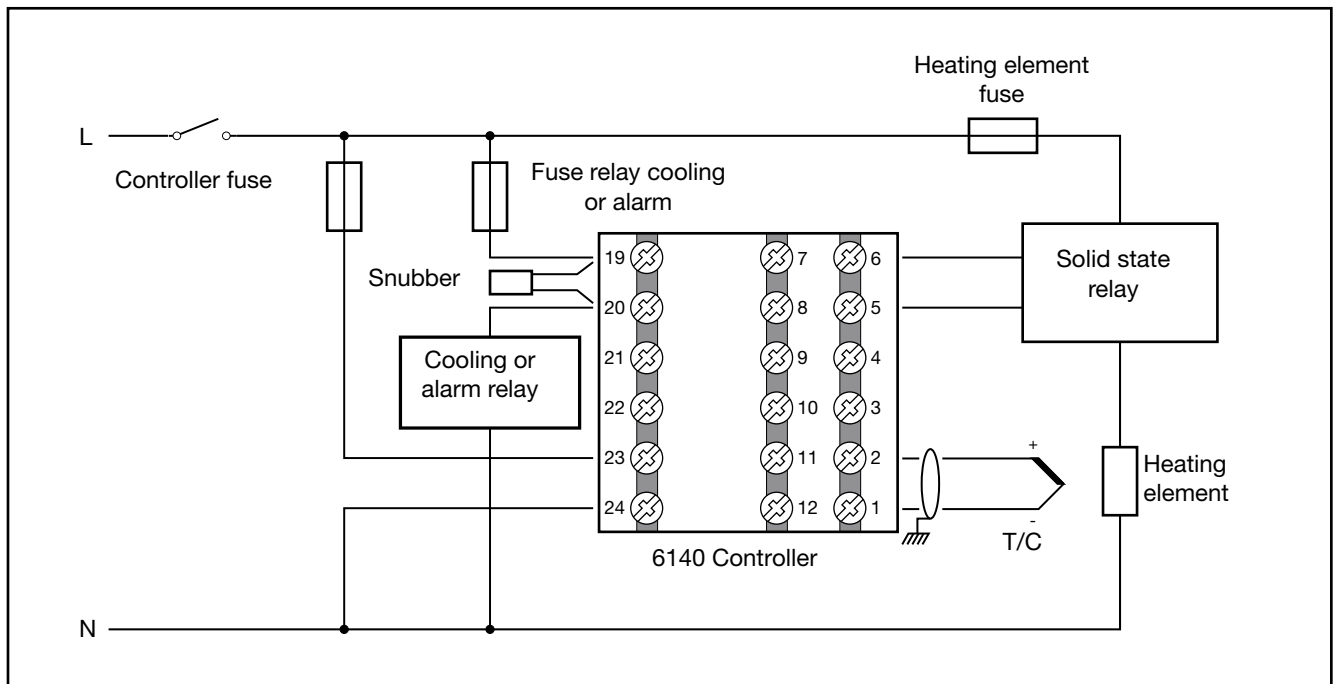



## 5.2. Heating control and current (CT) application

A 6140 controller (model 6140-D-R00-00100-1) controls a heating element via a solid-state relay connected to a logic output.

A TC sensor measures the temperature.

Each branch of the circuit is protected by a fuse.

The alarm relay is protected by a snubber.

A current transformer is connected to a dedicated input to indirectly measure electrical consumption.

The following diagram shows the various connections.

One switch can control more than one controller.

With Quick Configuration you set:

- sensor type (TC);
- unit of measurement of temperature (°C);
- the logic output function (HEAT);
- the relay output function (ALRM1);
- the full-scale value of the CT1 current transformer (HI. CT1)
- the setpoint, i.e. the temperature to be maintained (SETP);
- the temperature value that trips the alarm (ALRM1).

### 5.2.1. Connection diagram

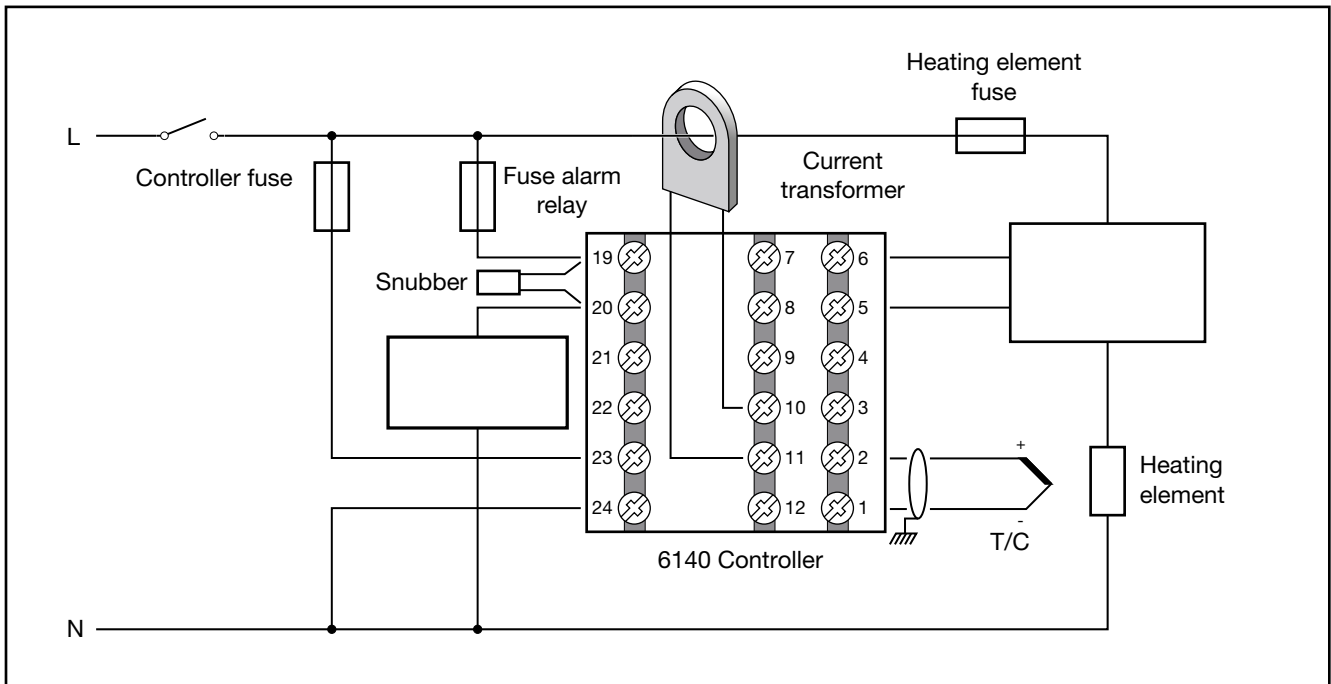



### 5.3. Remote setpoint input

The value of the analog remote setpoint input is shown in the parameter SETPR.

The function can be:

- display only (with settable alarms if required);
- process variable (PV) setpoint if the controller is in REMOTE mode;
- POWER setpoint if the controller is in MANUAL and REMOTE mode

The maximum and minimum scale values of the input are shown by read-only parameters LO.SPR and HI.SPR on the user configuration menu.

The parameter SETPR is shown in read-only on the user configuration menu.

### 5.4. 4-point input correction

The 4-point input correction lets you correct the read of the main input and/or of the remote setpoint input by setting four values: A1, B1, A2 e B2.

To enable the function, set parameter Lin to 4.POIN (I.MAIN menu or I.SPR menu).

The limitations are:

- B1 must always be larger than A1;
- B1-A1 must be greater than 10% of the top of the scale of the selected probe.

The setting is limited to the preset scale LO.SCL... HI.SCL on the I.MAIN menu (or I.SPR). The offset function (parameter OF.SCL, I.MAIN menu) remains enabled.

By using this function for linear scales (60 mV, 1 V, 5 V, 10 V, 20 mA) you can invert the scale.

The four values are set on the LINRZ menu as follows:

- A1 = STP.00
- B1 = STP.01
- A2 = STP.02
- B2 = STP.03

#### Example

Select Pt100 input with Lin = 4.POIN to obtain an RTD sensor with 4-point input correction.

Input Pt100 with:

- Lin = 4.POIN (Pt100 natural scale -200...850),
- DEC.P = 0
- LO.SCL = 0
- HI.SCL = 400

The reference points on the real curve (input) are:

- A1 = STP.00 = 50,
  - B1 = STP.01 = 350,
- B1-A1 = 300, which is larger by 85 (10% of 850).

The corresponding points on the corrected curve (indication) are:

- A2 = STP.02 = 120,
- B2 = STP.03 = 220.

With the corrected curve an input value of 200 is displayed as 170.

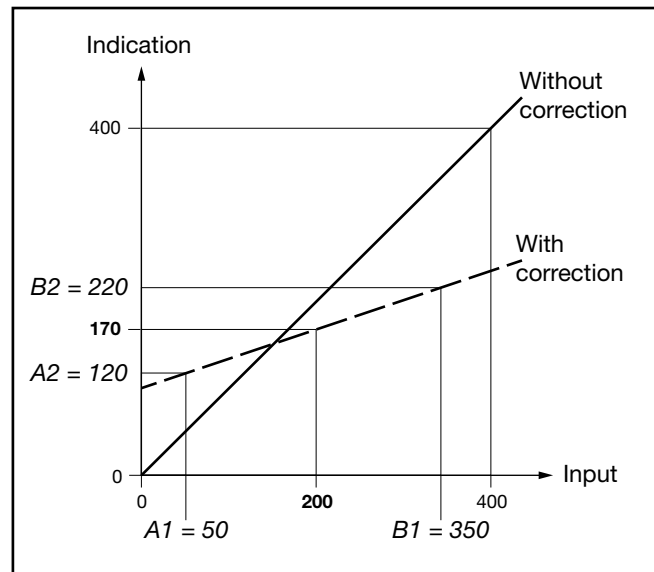

Figure 17 - Diagram of 4-point input correction, for the example (Pt100 input)

### 5.5. Current inputs

The values of current inputs CT1 and CT2 are shown in parameters CURR1 and CURR2.

These values are used in generic alarms AL1... AL4 and especially for the HB alarm

The maximum scale value of the input is shown by parameter HI.CT1 on submenu I.CT1 for CT1, and by parameter HI.CT2 on submenu I.CT2 for CT2.

## 5. EXAMPLES AND APPLICATIVE NOTES

### 5.6. Alarms

#### 5.6.1. Generic alarms AL1...AL4

Generic alarms AL1...AL4 can be mainly 4 types, as described below:

##### Absolute alarm

AL1 inverse and absolute, AL2 direct and absolute. Two alarm setpoints, AL1 (lower setpoint) and AL2 (upper setpoint) are set, corresponding to two specific hysteresis values, Hyst1 (positive) and Hyst2 (negative). The alarm trips when the measured value remains less than AL1 or greater than AL2 for the set delays. The alarm condition ends when the measured value is greater than AL1 + Hyst1, or less than AL2 - Hyst2. This prevents repeated alarms caused by slight changes in the measured value. Any alarm message at power-on, when the equipment is not at full speed, can be avoided by setting disable at power-on.

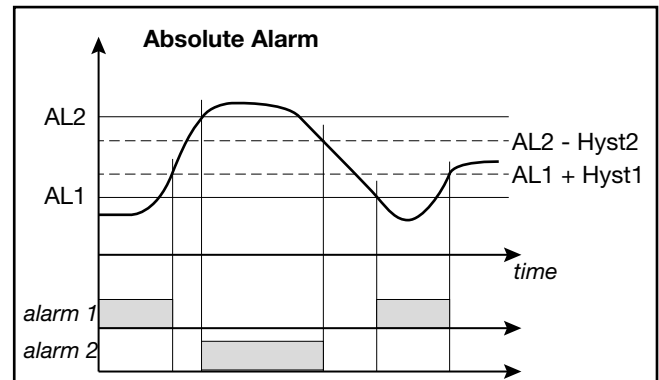

##### Symmetrical absolute alarm

A single alarm setpoint AL1 and a single hysteresis value Hyst1 are set. When a direct alarm is set, the alarm trips when the measured value is less than AL1 - Hyst1 or greater than AL1 + Hyst1 for the set delay. When an inverse alarm is set, the alarm trips when the measured value is greater than AL1 - Hyst1 or less than AL1 + Hyst1 for the set delay.

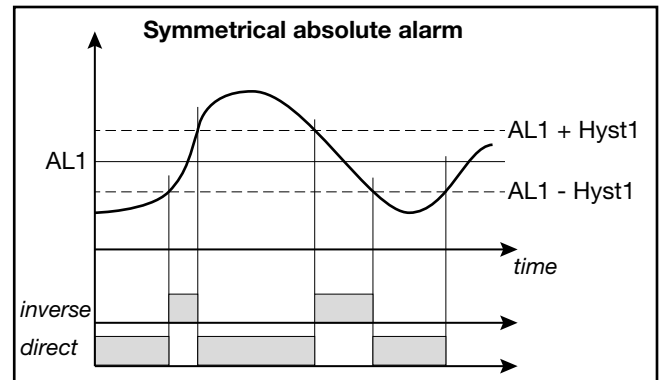

##### Deviation alarm

A single alarm setpoint AL1 and a single hysteresis value Hyst1 (negative) are set. When a direct alarm is set, the alarm trips when the measured value is greater than SP + AL1 for the set delay. The alarm condition ends when the measured value is less than SP + AL1 - Hyst1. When an inverse alarm is set, the alarm trips when the measured value is less than SP + AL1 - Hyst1 for the set delay. The alarm condition ends when the measured value exceeds SP + AL1. The deviation alarm lets you implement dynamic setpoints that automatically follow the trend.

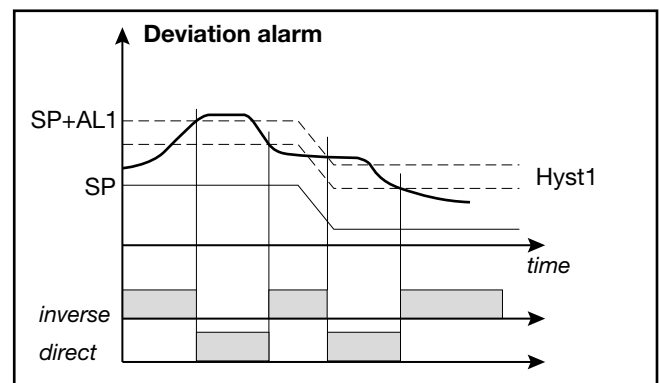

##### Symmetrical deviation alarm

A single alarm setpoint AL1 and a single hysteresis value Hyst1 are set. When a direct alarm is set, the alarm trips when the measured value is less than SP - AL1 or greater than SP + AL1. When an inverse alarm is set, the alarm trips when the measured value is between SP - AL1 and SP + AL2.

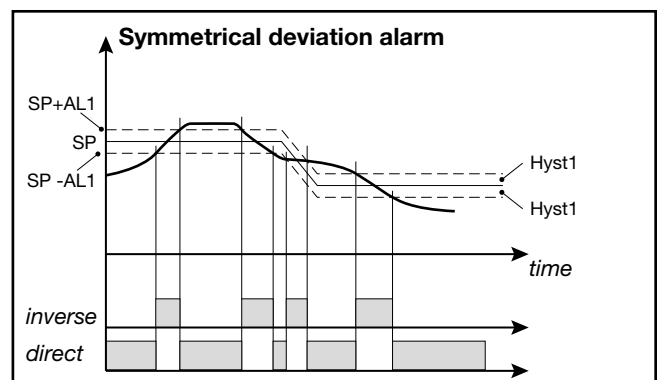

5.6.2. HB alarm

This type of alarm calls for the use of the current transformer input (I.CT1 / I.CT2), which is assigned to a control output, from which the ON and OFF phases are considered.

The alarm signals changes in load draw, discriminating the value of currents for current inputs I.CT1 and I.CT2.

The alarm is active if the rms current value:

- is below set value LOW.ON in the ON time of the of the assigned control output,
- is above set value HIG.ON in the ON time of the of the assigned control output,
- is above set value HI.OFF in the OFF time of the of the assigned control output.

Single tests are disabled by setting a value of "0.0".

The HB alarm trips if one of the above setpoints is exceeded for the set TIME.

Each of the three conditions may indicate a problem in the process managed by the assigned control output.

HB alarm tests are activated only with ON times of the assigned output longer than 0.4 seconds.

The alarm resets automatically if the condition that caused it is eliminated.

The load current is shown by parameters CURR1 and CURR2 on the user configuration menu.

**Note:** ON/OFF times refer to the cycle time set for the control output selected in OUT.

During configuration, you have to indicate load type with LoAd, specifying if it is a monophasic load with only one current transformer CT1 (MONO), a 3-phase star load no neutre with CT1 and CT2 (STAR), or a 3-phase delta load with CT1 and CT2 (DELTA).

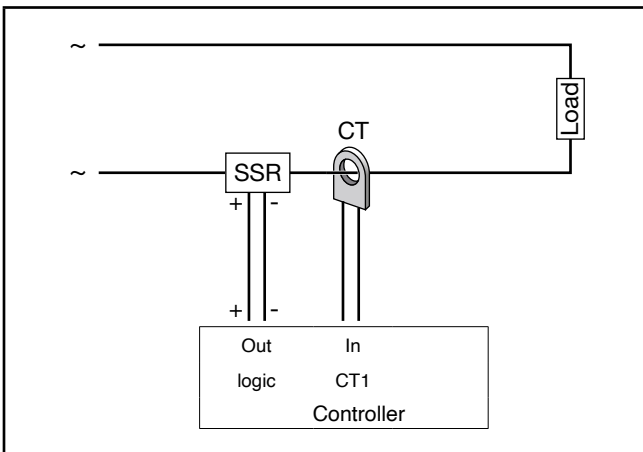

Figure 18 - HB alarm with monophasic load

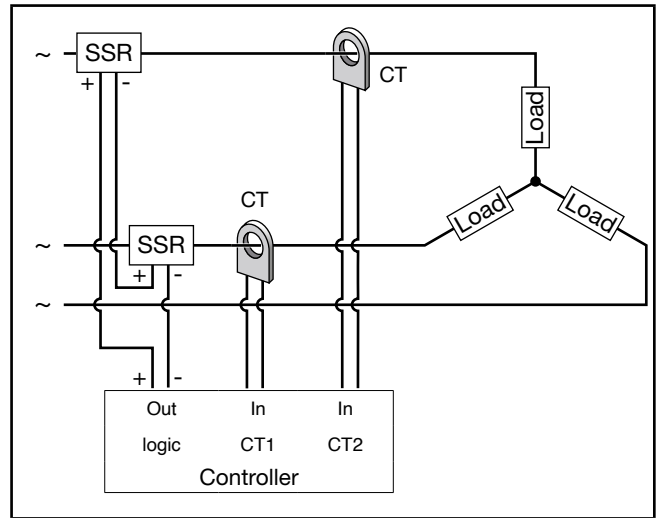

Figure 19 - HB alarm with 3-phase star load without Neutral

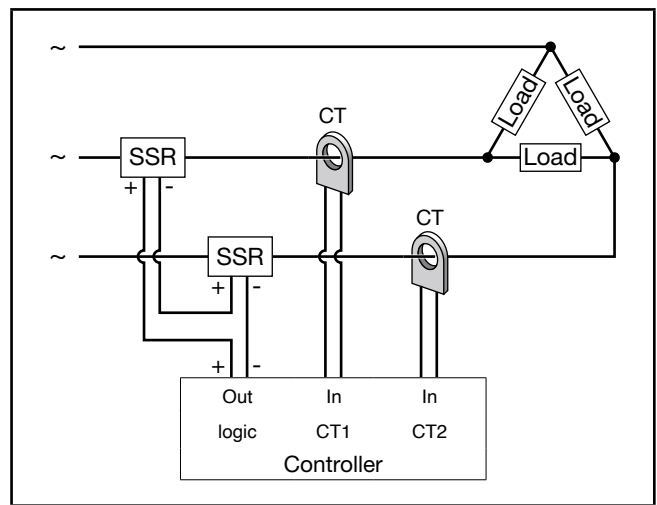

Figure 20 - HB alarm with 3-phase delta load

A 3-phase load can be controlled by means of a logic output connected in series to two SSR modules.

5.6.3. HB alarm calibration

Calibration is possible:

- by user calibration U.CAL = AL.HB (turning the selected output on in OUT)
- as a function of the settable front key (but.1 for model 6140, but.1 or but.2 or but.3 for model 4140); to acquire the current value, the power in automatic or manual must be > 10%; press the key to confirm the percent value (set in parameter THR.PE) of the current value that is saved in parameter LOW.ON.

5.6.4. LBA alarm

This alarm signals an interrupt in the control loop as a possible consequence of a sensor in short circuit, an inverted sensor, or a load break.

It trips an alarm if the variable does not increase its value in heating (or does not decrease it in cooling) when maximum power is supplied for settable time LBA.TM.

If the parameter is set to LBA.TM = 0 the LBA function is disabled.

## 5. EXAMPLES AND APPLICATIVE NOTES

---

The value of the variable is enabled only outside the proportional band. With the alarm active, power is limited to the value LBA.PW and the PV display flashes.

The alarm condition ceases if the temperature increases in heating (in case of decrease in cooling), by setting AL.ACK = On on the user configuration Menu, or by switching to Manual mode.

The LBA alarm is disabled in the presence of ON-OFF control (of heating, cooling, and heating/cooling). In the presence of PID control with ON-OFF heating or cooling, LBA.PW can only be set for the PID part

### 5.7. Retransmission output

---

The retransmission output is used mainly to retransmit the OUT.PW control power.

The percentage of actuation value is shown by read-only parameter OUT. AN on the user configuration menu.

### 5.8. Switching the software on/off

---

#### 5.8.1. How to switch it off

Keep the **[F]** and **[△]** keys pressed for 5 seconds to deactivate the controller.

The device goes to an “OFF” state and assumes the behavior of a controller switched off.

The voltage is not switched off: the process variable (PV) display stays on, but the SV display is off.

All of the outputs (control and alarms) are in an OFF state (logic level 0, relays de-excited) and all controller functions are inhibited except for the “POWER-UP” function and serial communication.

#### 5.8.2. How to switch it on

Keep the **[F]** key pressed for 5 seconds: the controller goes from “OFF” to “ON” state.

If voltage is switched off during the “OFF” state, at the next Power-up the controller returns to “OFF” state (the controller latches the “ON/OFF”).

The key-off function is normally enabled. To disable it, set the parameter On.OF = disab. on the MODE configuration menu.

This function can be assigned to a digital input (F.in.x, parameter ON-OF), excluding deactivation from the keypad.

### 5.9. Soft-Start

---

If enabled (by setting SOFT.S = ON on the PID configuration menu), the Soft-Start function slices power based on the percentage of time lapsed since controller power-on compared to the time set in the parameter SOFT.T

Soft-Start is an alternative to Self-Tuning and is activated after every controller power-on.

The Soft-Start action is reset in Automatic-Manual switching.

### 5.10. Tuning

---

#### 5.10.1. Tuning actions

Tuning actions are divided into 3 categories:

- **Proportional:** action in which the contribution on the output is proportional to the deviation in input.
- **Derivative:** action in which the contribution on the output is proportional to the speed of change of the deviation in input.
- **Integral:** action in which the contribution on the output is proportional to the integral in time of the deviation in input.

The deviation is the offset between the measured value of the controlled variable and the setpoint.

Tuning actions let you achieve optimum tuning of the controlled process in every phase.

##### 5.10.1.1. Influence of Proportional, Derivative and Integral actions on response of controlled process

The response of the controlled process depends on the type of control action set. Specifically:

- Increasing the Proportional Band reduces oscillations

but increases the deviation.

- Decreasing the Proportional Band reduces the deviation but causes oscillations of the controlled variable (excessively low Proportional Band values make the system unstable).
- Increasing the Derivative Action, corresponding to an increase in Derivative Time, reduces the deviation and prevents oscillations up to a critical value of Derivative Time, beyond which it increases the deviation and causes prolonged oscillations.
- Increasing the Integral Action, corresponding to a decrease in Integral Time, tends to cancel the deviation at full speed between the controlled variable and the setpoint.
- If the Integral Time value is too long (weak Integral action), there may be persistence of the deviation between the controlled variable and the setpoint.

For more information on tuning actions, contact Chromalox Customer Care.

5.10.2. Manual tuning

Manual tuning is done as follows:

1. Set the setpoint to the working value.
2. Set the Proportional Band to 0.1% (with ON-OFF control).
3. Switch to automatic and watch the behavior of the variable.  
There will be behavior similar to that shown in the following figure.

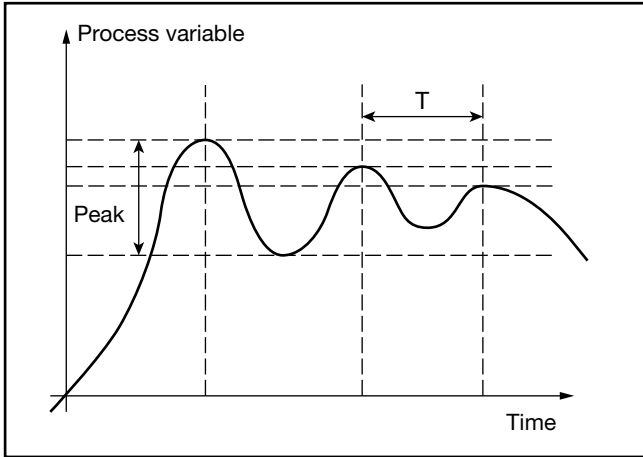

4. Calculate the PID parameters:
  - Proportional Band P.B. value

$$P.B. = \frac{\text{Peak}}{V_{\max} - V_{\min}} \times 100$$

where  $V_{\max} - V_{\min}$  is the scale interval.

- Integral Time value  $It = 1.5 \times T$
  - Derivative Time value  $dt = It / 4$
5. Switch the controller to manual.
  6. Set the calculated parameters (re-enable PID control by setting a cycle time for relay output if necessary).
  7. Switch to automatic.
  8. To check optimization of the parameters, change the setpoint value if possible and check transitory behavior: if oscillation persists, increase the Proportional Band value; on the other hand, if the response is too slow, decrease the value.

5.10.3. Self-Tuning

Self-Tuning is a simplified and automatic tuning mode based on the process state.

The purpose of Self-Tuning is to calculate optimum control parameters at the start of the process.

The variable (for example, temperature) must be the one measurable at zero power (room temperature).

You can automatically start tuning at every power-on or start it by means of the appropriately configured ( ) key.

The procedure runs automatically by optimizing the approach in relation to the real temperature value, in case of (relay, solid-state, Triac) control output, with automatic calculation of optimal cycle time CY.TIM.

At the end of the procedure, the following new PID parameters are saved:

- proportional band,
- integral and derivative times, calculated for the cur-

rent action (heat or cool).

In case of dual action (heat + cool) the parameters are calculated automatically separately for the two actions.

Active tuning condition is signaled on the display by an LED



**Attention!** Self-Tuning is not applicable with an ON/OFF control.

Notes

- For the programmer model, if Self-Tuning starts when the controller is powered-on, the program is in STOP.
- If SP-PV deviation is less than 0.3% f.s., Self-Tuning switches to “one shot” Auto-Tuning; otherwise it calculates a point at 75% of deviation around which to start “one shot” Auto-Tuning, considering a single Heat or Cool action or a dual Heat/Cool action based on the type of set control.

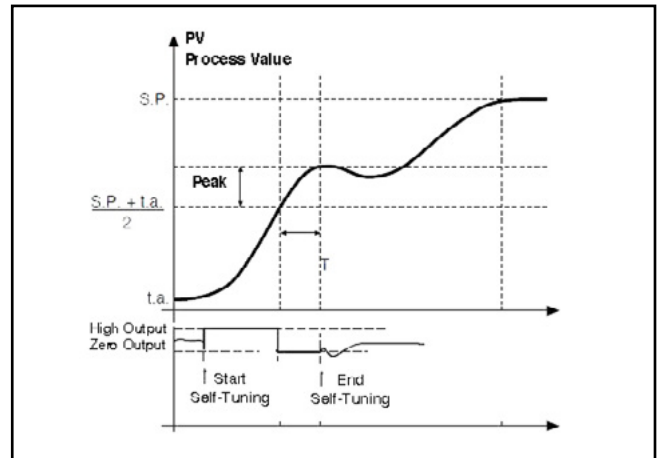

Example single action, PV less SP/4

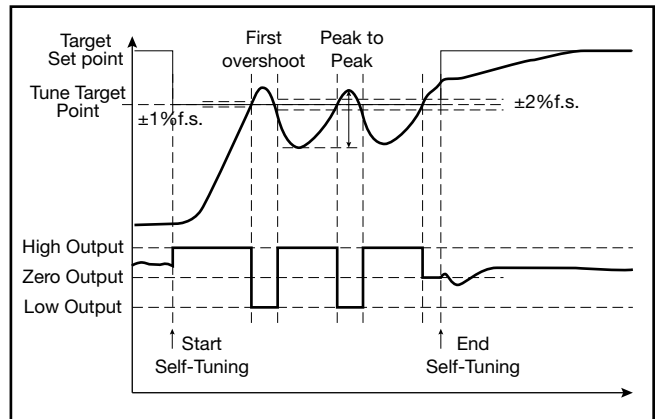

## 5. EXAMPLES AND APPLICATIVE NOTES

Example dual heat/cool action, PV greater than SP/4

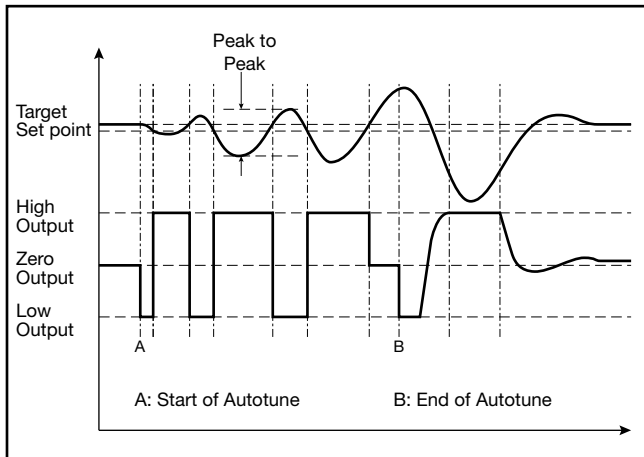

Example with SP-PV deviation less than 0.3% f.s. dual heat/cool action

### 5.10.4. Auto-Tuning

Enabling the Auto-Tuning function blocks the settings of the PID parameters.

There are two types: continuous and one-shot.

Continuous Auto-Tuning constantly measures system oscillations, immediately searching for PID parameter values that reduce the current oscillation. It does not act if the oscillations drop to values below 1.0% of the Proportional Band. It is interrupted if the setpoint changes and automatically resumes with a constant setpoint.

The calculated parameters are not latched if the device switches off, if it goes into manual, or if the configuration code is disabled.

The controller resumes with the parameters programmed before enabling Auto-Tuning.

The calculated parameters are latched when the function, enabled from digital input or key  $\square$ , is disabled.

One-shot" Auto-Tuning can be started manually or automatically. It is useful for calculating PID parameters when the system is around the setpoint.

"One-shot" Auto-Tuning produces a change in the control output up to a maximum of  $\pm 100\%$  of current control power (limited with H.P.HI...H.P.LO for heat and with C.P.HI...C.P.LO for cool) and evaluates the effects in time overshoot.

The calculated parameters are latched. It starts manually via digital input or via Tuning key after an undershoot/overshoot. It starts automatically (with error band of 0.5%) when the PV-SP error goes beyond the set band (programmable at 0.5%, 1%, 2%, 4% of full-scale).



**Attention!** At power-on or after a setpoint change, automatic start is inhibited for a time equal to five times the integral time (with minimum of 5 minutes). The same time has to pass after running "One-shot" Auto-Tuning.

### 5.10.5. Examples of tuning

The two diagrams below show the time change in the monitored value and the change in the controlled tuning output.

- PV = Process variable
- SP + cSPo = cooling setpoint
- $cSPo = C.SP (HI.SCL - LO.SCL) / 100$
- C.PB = Proportional cooling band
- SP = heating setpoint
- H.PB = Proportional heating band

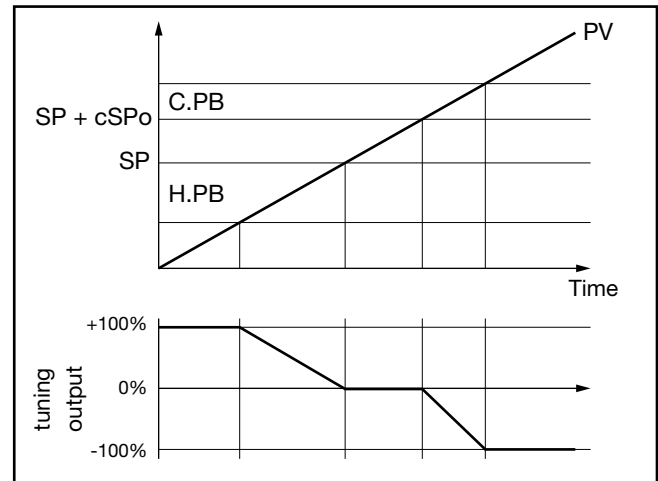

Tuning output only with proportional action in case of proportional heating band separate from cooling band.

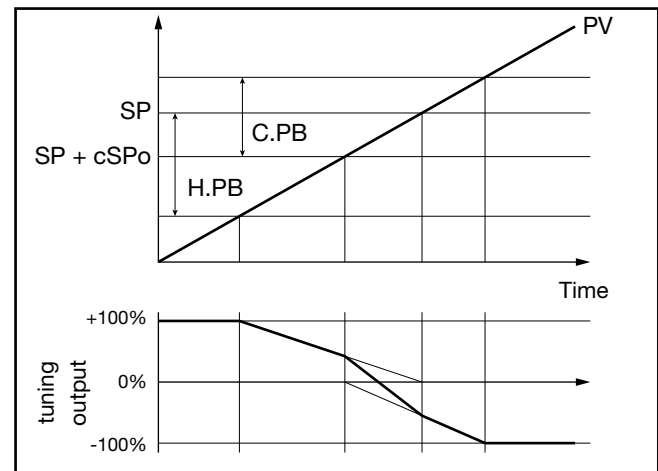

Tuning output only with proportional action in case of proportional heating band superimposed on cooling band.

### 5.10.6. Heat/Cool tuning with relative gain

For this tuning mode (enabled on the PID menu with parameter Cntr = PID.RG) you have to specify the cooling type (COOL parameter).

The PID cooling parameters are calculated starting from heating parameters in the specified ratios:

- **Air** relative gain  $H.PB / C.PB = 1$
- **Water** relative gain  $H.PB / C.PB = 0.8$
- **Oil** relative gain  $H.PB / C.PB = 0.4$

#### Example

Starting with the following heat data:

- COOL = oil

## 5. EXAMPLES AND APPLICATIVE NOTES

- H.PB = 10.0
- H.IT = 4.00
- H.DT = 1.00

there will be the following cool data:

- C.PB = 12.5
- C.IT = 4.00
- C.DT = 1.00

For slicing cycle times for outputs, the following values should be set:

- **Air** CY.TIM Cycle T Cool = 10 seconds
- **Water** CY.TIM Cycle T Cool = 2 seconds
- **Oil** CY.TIM Cycle T Cool = 4 seconds



**Attention!** Cool parameters cannot be changed in this mode.

### 5.11. Timer

The timer is enabled on the MODE configuration menu by selecting TIMER = On.

In case of enabling, select the function F.tiM on the TIMER submenu by choosing among:

- ST.STP: Start/Stop timer
- STABL: stabilization timer
- SWITC: power-on timer

If the timer is set with the FunC = SWITC function (= Switch-on timer after a POWER ON), the instrument will turn on (with SW switch-on) after the time set in the timer has elapsed.

When the count is on, you can see the timer value on the SV display, on the F display, or on the bargraph by setting the parameters dS.SP = TIM.EL, dS.F = TIM.EL or bArG = TIM.EL, respectively.

You can also assign a message to be displayed when the count is on.

When the set TIMER time is reached, you can:

- activate an OUT1...OUT4 output configured with F.ou.x = TIMER,
- go to software off with End = OFF,
- select setpoint 2 with End = SP1-2.

#### Controlling timer from keyboard

If the digital inputs are not enabled, the timer is controlled when TIM.EL is displayed by using the  $\Delta$ ,  $\nabla$  keys as follows:

- $\Delta$  pressed with timer stopped = START
- $\nabla$  pressed with timer running = STOP
- $\Delta$  +  $\nabla$  pressed for 2 seconds = RESET

#### 5.11.1. Start/Stop Timer

By selecting the options, you can alternately assign the StSt start/ stop timer function to:

- a digital input IN.DIG;
- an active alarm ALRM1 or ALRM2 or ALRM3 or ALRM4 or AL.HB;
- a serial SERIA.

You can select the true POSIT state or false NEGAT state for the start/stop command.

With parameter rESE, you can alternately select the timer reset mode:

- autoreset with timer in stop AUT.RS;
- from digital input IN.DIG;
- from active alarm ALRM1 or ALRM2 or ALRM3 or ALRM4 or AL.HB;
- a serial SERIA.

You can select the true POSIT state or false NEGAT state for the reset command.

The timer setpoint is settable with a full-scale of 9999 seconds.

The reset function, always active on the state, resets the Timer value and keeps it blocked even if start is present. In the absence of enabling (stop), the autoreset condition can be active, which resets the timer at every stop.

**The timer can also be controlled (start, stop and reset) with Function Blocks. In this case, the start and reset commands are in OR with the ones defined with the StSt and rESE parameters.**

The following diagrams show timer behavior when enabling from digital input and from alarm are used.

Switching between SETP1 and SETP2 is based on the value of the up gradient GRAD.I (if SETP2 > SETP1) or down gradient GRAD.D (if SETP2 < SETP1).

Switching is immediate if the gradient is set to 0 (zero). SP1/SP2 are managed only if the Multiset function is enabled, as indicated in the End parameter

#### Enabling from digital input

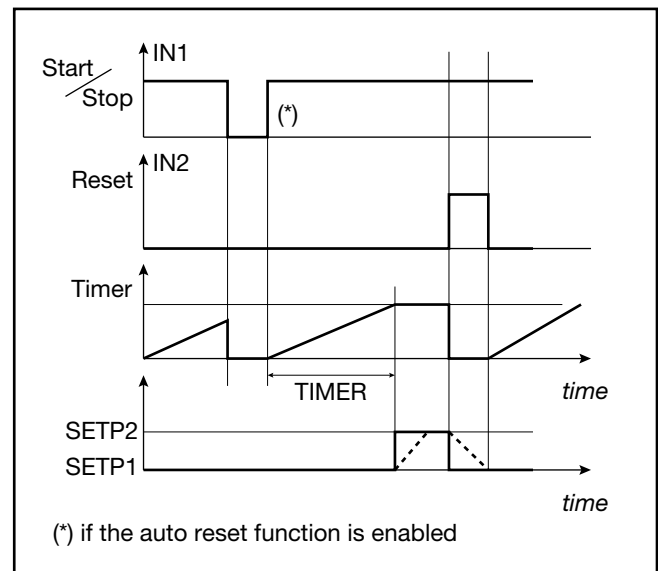

## 5. EXAMPLES AND APPLICATIVE NOTES

### Enabling from alarm

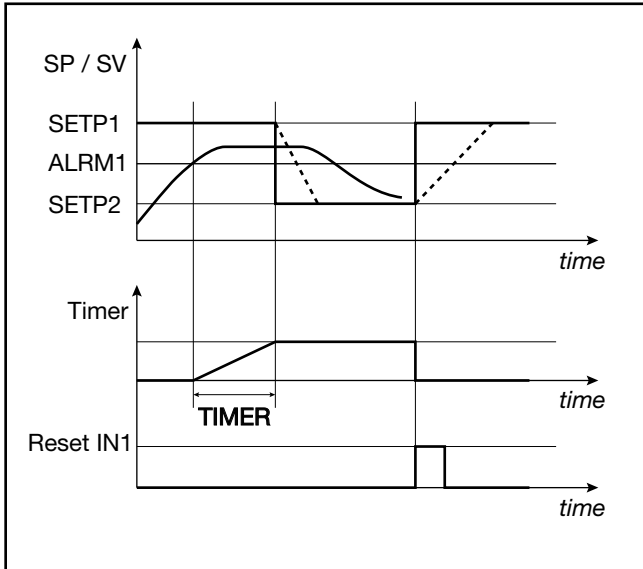

### 5.11.2. Stabilization timer

The stabilization timer is used to control a process at a certain temperature for a certain time. The band defining stabilization of the temperature is settable in BAND (from 0.0% to 25.0 % f.s.); the time is set in TIME. With the band set to 0.0% the count starts the first time the setpoint is reached.

When the function at end of count is End = SP1-2, the end count state activates when the setpoint reaches value SETP2 based on the value of the up gradient GRAD.I (if SETP2 > SETP1) or down gradient GRAD.D (if SETP2 < SETP1). Switching is immediate if the gradient is set to 0 (zero).

The following diagrams show how the stabilization timer works and the state of the end count output.

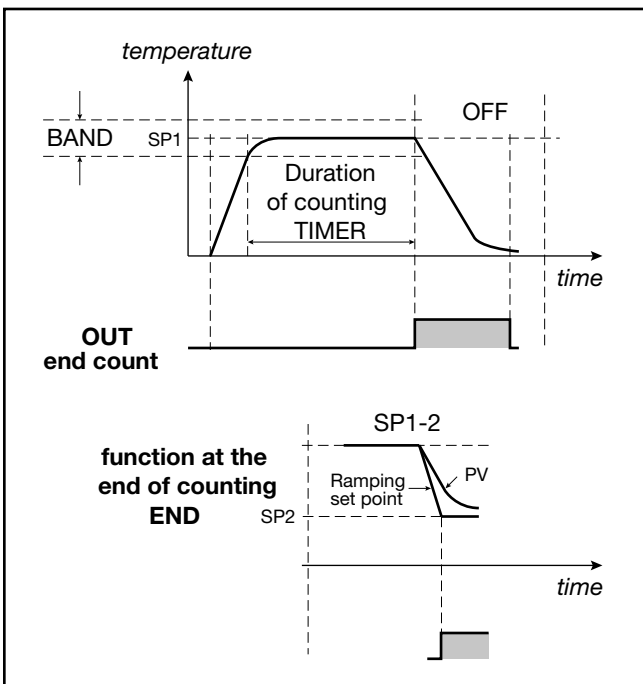

### 5.11.3. Start timer

The start timer is used to start the control a certain time after the controller is powered-on.

The delay after start/power-on is settable in TIME.

The following diagrams show how the start timer works and the state of the end count output.

The instrument therefore remains in software shutdown while the timer is counting.

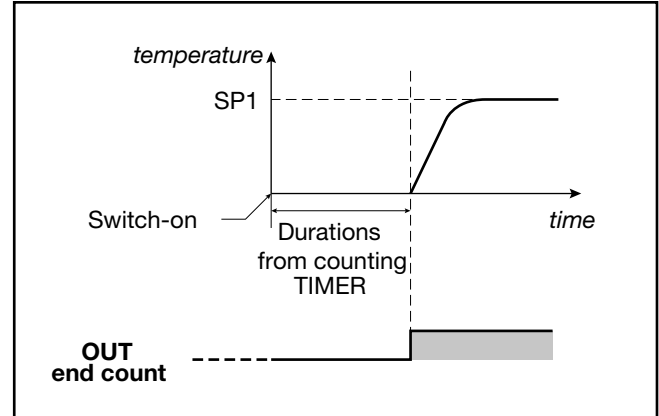

### 5.11.4. Variables available for the user configuration menu

The variables available for the timer are TIM.RE, which shows remaining time, and TIME.EL, which shows lapsed time.

## 5.12. Multiset, setpoint gradient

The Multiset function is enabled in configuration mode by selecting MUL.SP = On .

This function lets you set:

- 2 setpoints (SETP1 and SETP2) by using a digital input with function F.in.x = SP.SE.L or a configurable faceplate key (BUT1 for model 650, BUT1 or BUT2 or BUT3 for models 1250 and 1350) setting the option but.x = SP.SEL. on the HMI submenu.
- 4 setpoints (SETP1, SETP2, SETP3 and SETP4) by using two digital inputs, one with function F.in.x = SP.SE.L and the other with function F.in.x = SP.SE.H.

The selection of SETP1 and SETP2 is shown on the display via LED.

The setpoint gradient function is enabled on the PID submenu by setting the GRAD.I (up gradient setpoint) and/or GRAD.D (down gradient setpoint) parameters with a value other than 0.

At start and at Automatic/Manual switching, the setpoint is assumed equal to PV. With set gradient it reaches the Local/Remote setpoint or the setpoint selected in case of Multiset function.

Each change of setpoint is subject to a gradient: GRAD.I. for change from lower to higher setpoint, GRAD.D. for change from higher to lower setpoint.

The setpoint gradient is inhibited at start when Self-Tuning is enabled. The control setpoint reaches the set value with a speed defined by the gradient.

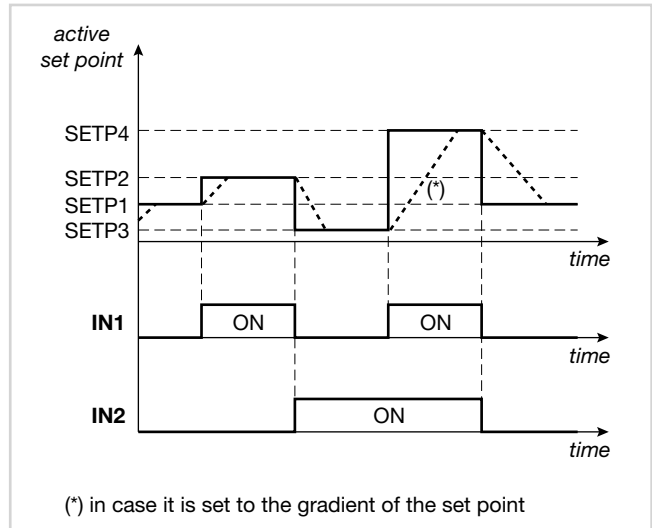

## 5.13. Setpoint programmer

### 5.13.1. What is a program

A program is a set of steps, each having a number of parameters, that let you control the value of a process or of a device based on lapsed time, on specific conditions, and on reference values saved in the controller or supplied to it from the outside.

In its simplest form, a step has two parts, represented on the graphs by two segments:

- a (possible) ramp, i.e., a variable change in the setpoint value time;
- a hold, i.e., a time in which the process value is held constant after it has reached the setpoint value.

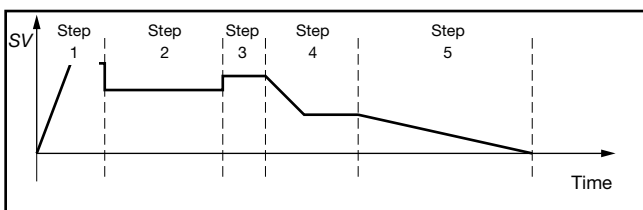

#### Standard programmer mode

A program can have a maximum of 32 steps and up to 4 programs can be saved in the controller. Each program is defined by the number of its first and last step.

#### Simplified programmer mode

In this mode a program consists of a fixed number of steps (maximum 8) and the instrument can store up to 4 programs of 8 steps each in memory

A program can be selected from the keypad, digital input or serial line.

The program can be controlled from the keys, digital inputs (START/STOP, RESET, end program), serial line, or events (output of Function Block).

### 5.13.2. Programmer functions

Depending on the model, the controller can combine the two functions of controller and single-loop programmer. Base time accuracy is 4 seconds every 10 hours

#### Programmer stop and restart modes

The programmer can be started or stopped from:

- digital input;
- key  $\triangle$  (START),  $\nabla$  (STOP) and  $\triangle + \nabla$  (RESET) in the absence of other enablings;
- alarm state (ON = START);
- different restart modes after a Power-off; (Power Off);
- setpoint preceding a Power-off;
- process variable value at time of Power-on;
- optimal search for setpoint forward/back in time;
- wait for Start.

## 5. EXAMPLES AND APPLICATIVE NOTES

### Changes possible in stop state

When the programmer is stopped, you can set or change:

- active setpoint;
- current step time;
- program number;
- step number;
- phase or segment (ramp or hold).

### Consents

You can assign up to 4 consents to each step.

Therefore, the start of a step can depend on a defined state of consents. If the state does not agree with the programmed state, the time base stops.

If the state agrees with the programmed state, execution proceeds with restart of the time base. Each digital input can be assigned to one consent.

### Events

You can assign up to 4 events to each step. At the start of the ramp and at the start of the hold of each step, the events are changed as programmed. Each digital output can be assigned to one event

### Other functions

- End program signal, with or without forcing of control outputs.
- Setting of a tolerance band relative to the setpoint. If the variable is outside the band, the time base is stopped (HBB alarm, Hold Back Band).
- Setpoint slaved with the same time base to manage a slaved controller via analog retransmission output A1.
- Total modularity of functions and parameters, with easy exclusion of ones not required

### 5.13.3. Programmer behavior

The change in local setpoint, which occurs during a program stop phase, causes the restart of the step in execution, with conservation of the set ramp time.

If the controller is switched off and then on again, program execution can continue, or restart from the first step, or search for the step with the setpoint closest to process variable PV.

Behavior at restart is defined by the value of the parameter Strt on the PR.OPT submenu.

STOP/START switching at end of program resets the program and restarts the program.

The Autoreset function implies that programmer reset is active in the stop phase, with consequent acquisition of PV value as active setpoint and resetting of the time base.

With the controller in manual, or with remote absolute setpoint, the programmer time base is stopped.

When switching from remote to local setpoint, the setpoint assumes the value of the remote setpoint at the time of switching if the parameter LO.rE = BUMPL.

### 5.13.4. Program examples

#### 5.13.4.1. ONE STEP program

Project conditions:

- ramp time = 0;
- hold;
- HBB enabling;
- switch-off

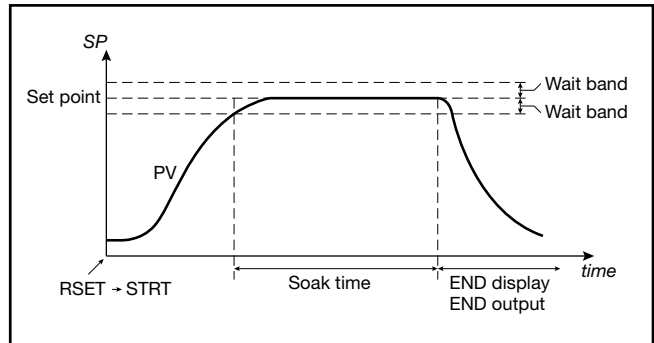

#### 5.13.4.2. ONE STEP program

Project conditions:

- ramp time = 0;
- hold;
- HBB enabling;
- hold at end of program.

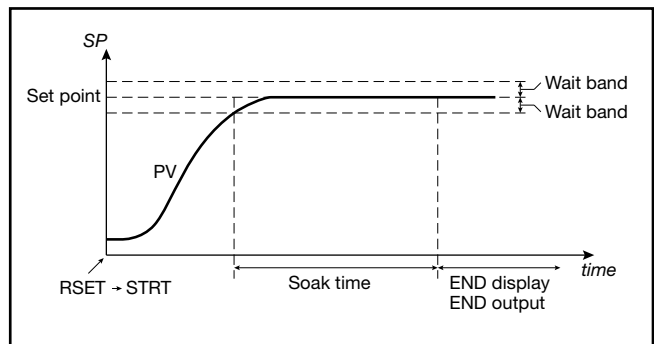

#### 5.13.4.3. Program with assigned events

Project conditions:

- Evt.1 On during STEP1;
- Evt.2 On during hold of STEP1;
- Evt.3 On during ramp of STEP2;
- Evt.4 not used.

STEP1 - setting events at start of step:

- EVN.r.1 = On
- EVN.r.2 = OFF
- EVN.r.3 = OFF
- EVN.r.4 = nonE

STEP1 - setting events at start of hold:

- EVN.h.1 = nonE
- EVN.h.2 = On
- EVN.h.3 = nonE
- EVN.h.4 = nonE

STEP2 - setting events at start of step:

- EVN.r.1 = OFF
- EVN.r.2 = OFF
- EVN.r.3 = On
- EVN.r.4 = nonE

## 5. EXAMPLES AND APPLICATIVE NOTES

STEP2 - setting events at start of hold:

- EVN.h.1 = nonE
- EVN.h.2 = nonE
- EVN.h.3 = OFF
- EVN.h.4 = nonE

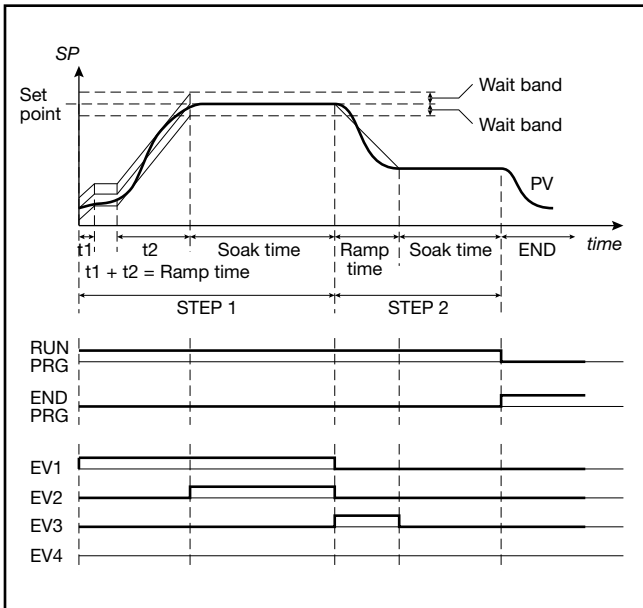

Using C-PWR software for the configuration, the displayed pages would be:

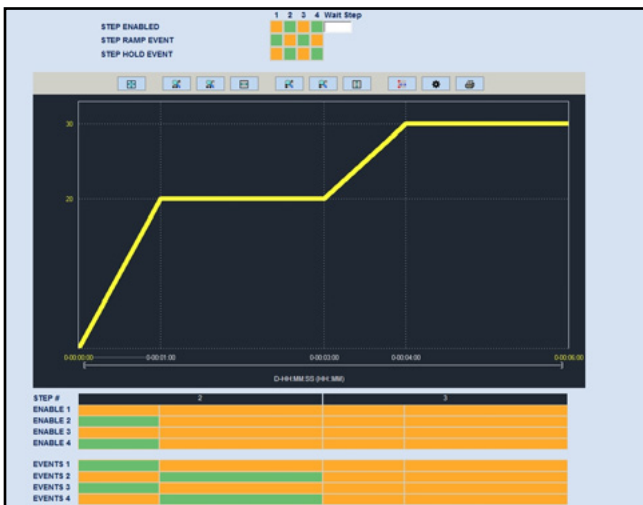

Program diagram

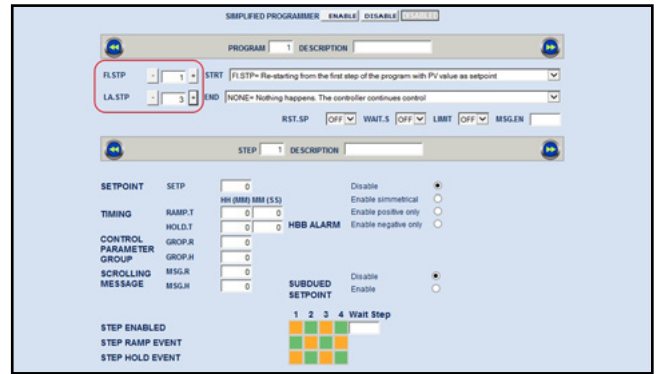

Setting up STEP1 in Standard mode

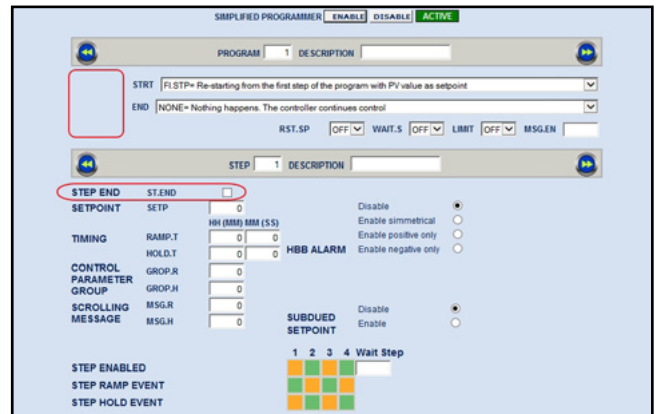

Setting up STEP1 in Simplified mode

## 5. EXAMPLES AND APPLICATIVE NOTES

### Cyclical program with 3 setpoints and 3 steps

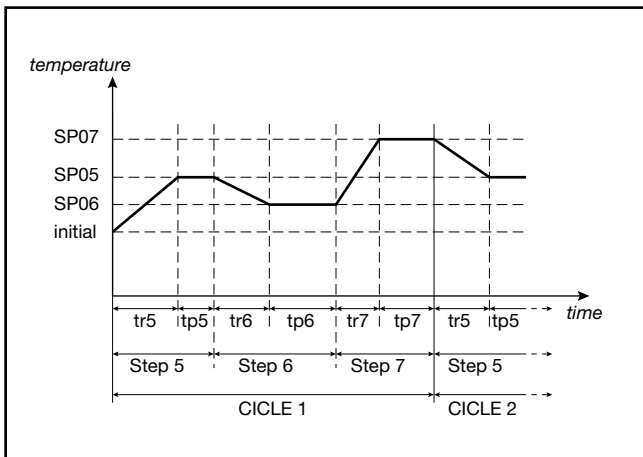

#### 5.13.4.4. Program with HBB (hold back band) function

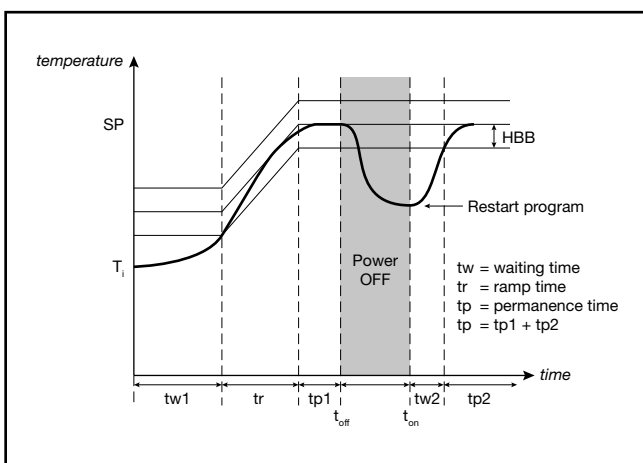

#### 5.13.5. Fast simulation of program

You can easily check a selected program by launching it in fast simulation mode. Enable it by setting the parameter LIMIT = On on the PR.OPT submenu.

The program will run with ramp time limited to 20 seconds and with hold time limited to 10 seconds. If the set values are smaller they are used. In this way the maximum duration of a step is 30 seconds.

During functioning in fast simulation, the HBB alarm is inhibited and the control output assumes the FAULT value on the PID submenu.

All other enabled functions (restart, start/stop, reset, manual/automatic, end cycle or continuous cycle, event outputs, consent from digital inputs, second channel setpoint, etc.) are active.

#### 5.13.6. Controlling the program from the keypad

In the absence of enablings from digital inputs, the program is controlled when programmer state is displayed using the  $\Delta$ ,  $\nabla$  keys, with the following modes:

- $\Delta$  pressed with program stopped = START;
- $\nabla$  pressed with program running = STOP;
- $\nabla$  +  $\Delta$  pressed for 2 seconds = RESET (condition maintained with key pressed);

When the programmer state is not displayed, the key ( ) maintains the function selected with the parameter but1.

#### 5.13.7. Programmer Reset mode

By setting RST.SP = ON provides that with active reset command the setpoint assumes the value of process variable PV and power is forced to zero.

Setting RST.SP = OFF maintains the active setpoint (prior to reset) and power control.

This function is valid in case of reset from digital inputs or enabled keys, as well as in case of reset following a program change (possible only in STOP) or STOP/START switching at end of program.

#### 5.13.8. Restart with step search

If configured, in case of restart the programmer can try to restart not from the first program step but from the point of the program that corresponds, or is closest to, the value of the active process variable PV.

This function mode is called "restart with step search."

At start, if Strt = RSCH was set on the PR.OPT submenu, the program searches for the setpoint with value equal to variable PV.

The search is conducted by shifting the current time forward or back and skipping phases or steps.

The following diagram shows a typical 5-step program profile and explains how restart with step search works

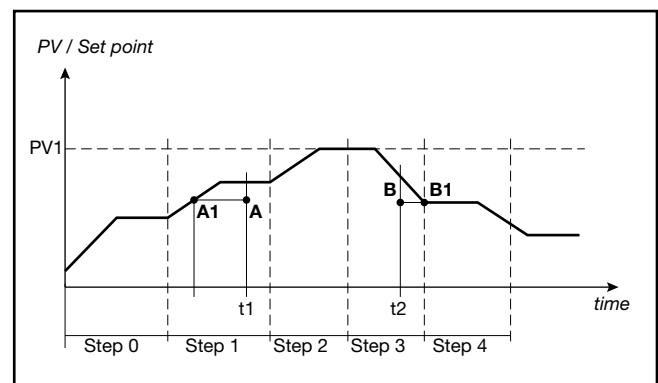

If the variable has values lower than the ones requested during a setpoint raise phase (point A, t1), restart is conducted by lowering the active time base until the setpoint profile (point A1) is intercepted.

If the variable has values lower than the ones requested during a setpoint lower phase (point B, t2), restart is conducted by raising the active time base until the setpoint profile (point B1) is intercepted.

If interception is impossible, as in the case of variable at value PV1, the program is restarted from the active setpoint and time.

If the HBB control is on, programmer base times remain in effect until the variable re-enters the set tolerance band, symmetrical to the setpoint value.

5.13.9. Simplified Programmer Mode

In Simplified Programmer Mode you can only use the PR.STP menu to set up programs.

To enable this mode, adjust the S.PROG parameter in the MODE menu (after enabling programmer mode using the PROGR parameter in the MODE menu).

There may be a maximum of 4 programs each, with a maximum of 8 steps, numbered from 1 to 8.

The FI.STP and LA.STP parameters in the PR.OPT menu disappear, as the first step in the selected program will always be number 1. In the PR.STP menu you may specify which of the 8 steps will be the last step in the program using the ST.END parameter.

The scrolling string reminds you which of the 4 programs you are editing.

**WARNING:** when switching the S.PROG parameter in the MODE menu from ON to OFF, you must obligatorily reset the FI.STP and LA.STP parameters in all programs, as they are not compatible with non-simplified mode.

In simplified mode, the FI.STP and LA.STP parameters disappear and the ST.END parameter appears for selecting the last step in the program:

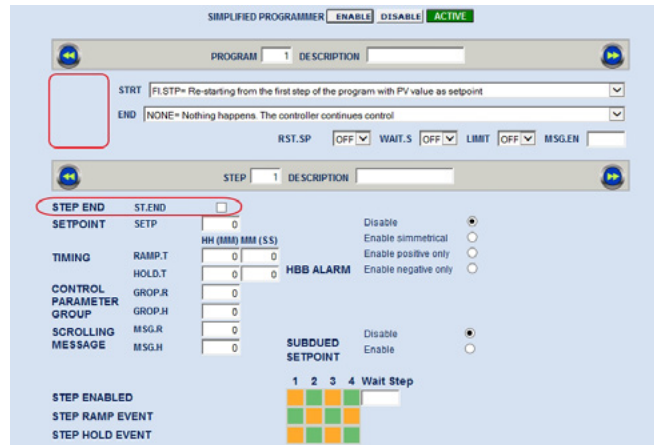

In both simplified and non-simplified mode, the C-PWR tool may be used for easy program set-up.

In non-simplified mode, the FI.STP and LA.STP parameters appear and may be freely set:

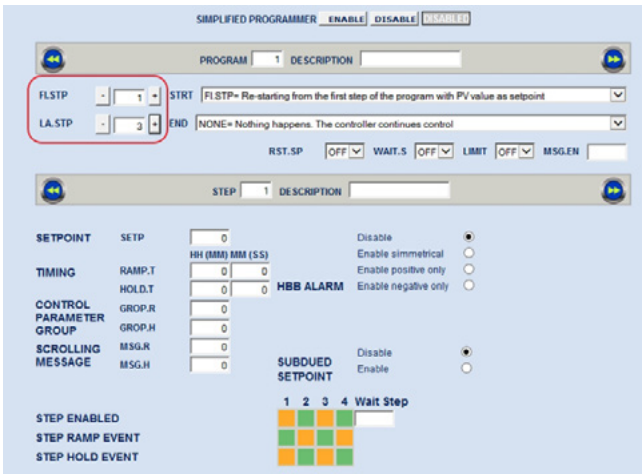

## 5. EXAMPLES AND APPLICATIVE NOTES

### 5.14. Managing motorized valves

In a control procedure, a motorized valve varies the flow rate of a fluid based on the signal from the controller. In an industrial process, the fluid may be a fuel, often corresponding to the thermal energy introduced into the process.

To change the flow rate, the valve has an actuator that modifies the valve's opening value, overcoming the resistance produced by the fluid flowing in it.

Control valves vary the flow rate in a modulated manner, producing finite variations in the fluid flow section corresponding to finite changes in the input signal from the actuator.

A typical actuator consists of an electric motor connected to the valve gate by means of a gearbox and a mechanical drive system.

The actuator can be integrated with various auxiliary components, such as mechanical and electrical safety limit switches, manual drive systems, and position readers.

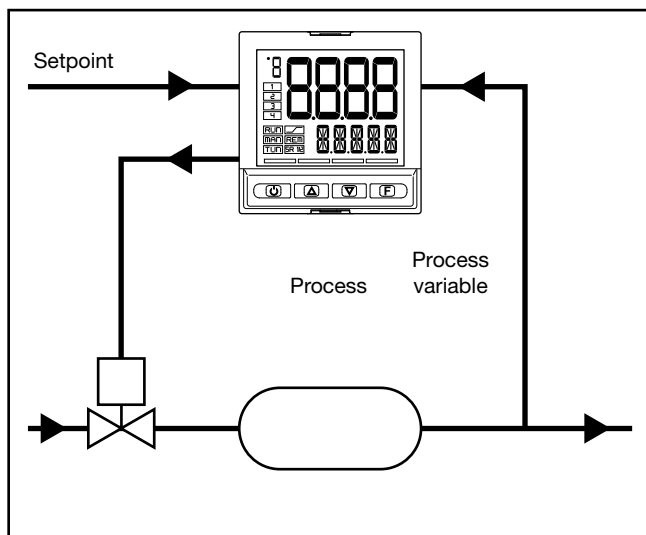

Figure 21 - Valve connection diagram

Based on process dynamics, the controller determines the output value that drives the valve actuator so that valve opening maintains the required process variable value.

#### 5.14.1. Valve control parameters

The controller controls the valves with the following parameters of the VALVE submenu:

- **TRAVL Actuator travel time:** the time the valve takes to go from completely open to completely closed (or vice versa). Settable with resolution of one second, this is a mechanical characteristic of the valve + actuator group.  
NOTE: if the actuator stroke is mechanically limited, reduce the TRAVL value proportionally.
- **TIM.LO Minimum impulse:** expressed as a percentage (with resolution of 0.1%) of actuator time, represents the minimum change in valve position corresponding to the minimum change in power supplied by the controller (power below which the actuator physically does not respond to the command).  
Raising TIM.LO lowers wear on the actuator to the detriment of precise positioning. Minimum impulse duration is settable in TIM.ON as a percentage of actuator time.
- **TIM.HI Impulse setpoint:** expressed as a percentage (with resolution of 0.1%) of actuator time, represents the deviation in position (requested position – real position) below which the maneuver request becomes impulsive. TIM.HI is only active with TIM.OF=0  
Impulse approach allows fine tuning of the position valve, which is especially useful in case of high mechanical inertia. Setting TIM.HI = 0 excludes positioning modulation.
- **TIM.ON:** it is the shortest time accepted for the valve command pulse, expressed as percentage of the “actuator time”
- **TIM.OF:** it is the shortest time between two Valve ON pulse command, expressed as percentage of the “actuator time”.  
Setting TIM.OF=0 this function is excluded.  
Setting TIM.OF <> 0 the Valve movement becomes pulsing; ON pulse time= TIM.ON and OFF pulse time= TIM.OF  
If the value TIM.OF < TIM.ON the value is forced to TIM.ON.
- **DEAD.B Deadband:** this is a deviation band between the control setpoint and the process variable within which the controller does not supply any command to the valve (Open = OFF; Close = OFF). It is expressed as a percentage of full-scale and is symmetrical to the setpoint. Once the process is defined, the deadband is used to prevent stressing the actuator with repeated commands that would be irrelevant to the control.  
By setting DEAD.B = 0 the deadband is excluded.

5.14.2. Valve control modes

In valve control, every request for a maneuver greater than minimum impulse is sent to the actuator via the relays with function V.OPEN / V.CLOS.

Each action updates the assumed position of the virtual potentiometer calculated on the basis of declared actuator travel time. This mode always provides an assumed valve position, which is compared with the controller's position request.

After reaching an assumed end position (fully open or fully closed determined by the virtual potentiometer), the controller supplies an additional command in the same direction, thereby ensuring that the real end position is reached.

The actuators are normally protected against an OPEN command in fully open position or a CLOSE command in fully closed position.



There are two setpoint approach modes:

- Non-impulsive behavior**  
 Set TIM.HI = 0 and TIM.OF=0 for non-impulsive behavior: every request greater than TIM.LO is continually sent to the actuator via the V.OPEN / V.CLOS outputs. The shortest pulse time is settable in TIM.ON as percentage of the "actuator time", it is recommended to set TIM.ON=TIM.LO  
 With power equal to 100.0% or to 0.0%, the corresponding output remains on.
- Impulsive behavior**  
 Set TIM.HI ≠ 0 and TIM.OF=0 for impulsive behavior. every request greater than TIM.LO is sent to the actuator via the V.OPEN / V.CLOS outputs with impulses having a duration of TIM.ON.  
 TIM.HI defines the deviation within which the movement becomes pulsing.  
 With power equal to 100.0% or to 0.0%, the corresponding output remains on.

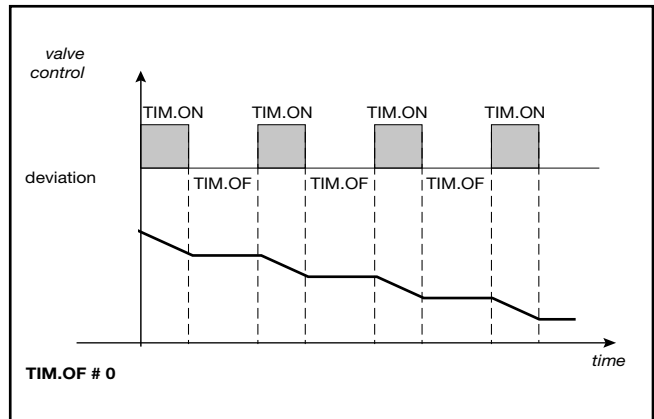
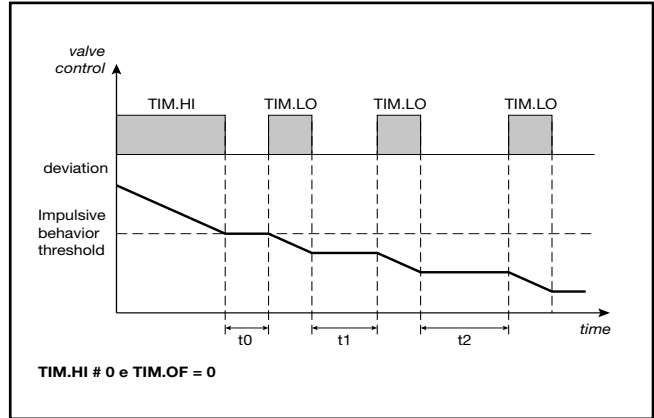
With TIM.OF ≠ 0, every request greater than TIM.LO is sent to the actuator via the V.OPEN / V.CLOS outputs with impulses having a duration of TIM.ON and TIM.OF. With power ≤ 10.0%, or ≥ 90.0%, the impulses are independent of TIM.LO. With power equal to 100.0% or to 0.0%, the corresponding output remains in modulation.



Impulsive behavior with TIM.OF ≠ 0

With the controller in manual, setting the parameter KEY.MO = On allows direct control of the valve open and close commands via the  and  keys.

5.15. Energy counter

The Energy Counter function lets you calculate the total energy transferred to the load and estimate its cost.

The Energy Counter function can be linked to a single output of the controller.

The output must be relay, logic or triac.

The following information can be displayed on the user configuration menu:

- Load current (parameter CURR). This is shown immediately if the option CT1 or CT1 + CT2 is present, or is calculated by using load power (parameter P.LOAD) and line voltage (parameter V.LINE) values, using the formula CURR = P.LOAD / V.LINE. CURR is indicated in amperes and can have values from 0.0 to 99.9.
- Power on load (parameter OUT.KW), calculated in kW. Power is calculated based on nominal power P.LOAD (as a %) or on RMS current if the option CT1 or CT1 +

CT2 is present. OUT.KW can have values from 0.00 to 99.99.

- Elapsed time to equal the energy (parameter EN.TIM) value between 0 and 999 hours
- Energy to the load (parameter OU.KWH) value between 0.00 and 99.99 kWh.
- Totalizer energy transferred to load (parameter EN.KWH), calculated in kWh. EN.KWH can have values from 0 to 9999. The counting of energy stops when it reaches the maximum 9999 kWh to a maximum of 999 hours time EN.TIM
- Cost of energy transferred to load (parameter EN.CST). Cost is calculated based on the nominal cost of energy per kWh (parameter E.COST), using the formula EN.CST = EN.KWH × E.COST. EN.CST can have values from 0 to 9999.

### 5.16. Logic Operations

#### 5.16.1. Function blocks

By means of Function Blocks, the Logic Operations function processes the values of input variables to obtain values for the output variables.

This lets you control the processes very precisely, because you can make a number of actions subject to a series of essential requisites.

The Function Blocks are run every 100msec in sequence, from FB1 to FB16.

Typical maximum delay from activation of an input and corresponding output = 100msec.

The Function Blocks are programmed with C-PWR software. There is a maximum of 16 Function Blocks. Each Block manages up to 4 input variables and 1 variable output. Four types of logic operations on input variables **a**, **b**, **c** and **d** can be performed on the Function Blocks

- (a AND b) OR (c AND d)
- (a OR c) AND (b OR d)
- a OR b OR c OR d
- a AND b AND c AND d

where the AND operator means that the linked operands must evaluate to “true” for the result to be “true,” whereas with the OR operator is it sufficient for only one linked operand to evaluate to “true” for the result to be “true”.

Parentheses change the order of evaluation of the expressions, i.e., expressions in parentheses are evaluated first, and the result is then used for expressions outside parentheses.

The input variables (**a**, **b**, **c**, **d**) to each Function Block can refer to:

- digital inputs (2 or 3 for model 650, 5 for models 1250 and 1350),
- state of alarms,
- state of control output,
- state of controller,
- state of setpoint programmer,
- variables FB\_OUT01...16 from other Function Blocks

The result of the Logic Operations function can act on:

- state of controller,
- state of setpoint programmer,
- state of alarms,
- outputs, by directly setting the state.

#### 5.16.2. Groups of variables

The controller provides a large number of variables that can be used in input for Logic Operations.

The controller has the following groups of homogeneous variables:

##### State Keys

BUT1  
BUT2  
BUT3

##### State of digital inputs

DIGITAL INPUT 1  
DIGITAL INPUT 2

DIGITAL INPUT 3  
DIGITAL INPUT 4  
DIGITAL INPUT 5

##### State of digital outputs

OUTPUT 1  
OUTPUT 2  
OUTPUT 3  
OUTPUT 4

##### Function commands

AU-MA (select Automatic / Manual)  
LO-RE (select Local / Remote)  
HOLD (hold main input variable)  
AL ACK (reset alarms latch)  
A.TUNE (start Auto-Tuning)  
S.TUNE (start Self-Tuning)  
ON-OFF (software ON-OFF)  
SKEY (block F key)  
WRI.EN (enable write configuration parameter)  
SP.SE.L (select SP1/SP2 or SP1...SP4 low bit)  
SP.SE.H (select SP1...SP4 high bit)  
T.STST (start/stop timer)  
T.RST (reset timer)  
P.STST (start/stop programmer)  
P.STRT (start programmer)  
P.STOP (stop programmer)  
P.RST (reset programmer)  
P.SKP (skip to end program)  
ST.SKP (skip to end step)  
ST.ENB.1 (consent 1 to start step)  
ST.ENB.2 (consent 2 to start step)  
ST.ENB.3 (consent 3 to start step)  
ST.ENB.4 (consent 4 to start step)  
LED.GREEN.1 (only for 1350 model)  
LED.GREEN.2 (only for 1350 model)  
LED.GREEN.3 (only for 1350 model)  
LED.GREEN.4 (only for 1350 model)  
LED.GREEN.5 (only for 1350 model)  
LED.GREEN.6 (only for 1350 model)  
LED.GREEN.7 (only for 1350 model)  
LED.GREEN.8 (only for 1350 model)  
LED.RED.1 (only for 1350 model)  
LED.RED.2 (only for 1350 model)  
LED.RED.3 (only for 1350 model)  
LED.RED.4 (only for 1350 model)  
LED.RED.5 (only for 1350 model)  
LED.RED.6 (only for 1350 model)  
LED.RED.7 (only for 1350 model)  
LED.RED.8 (only for 1350 model)  
LED.OUT.1  
LED.OUT.2  
LED.OUT.3  
LED.OUT.4  
RESET ALL DON  
RESET ALL DOFF  
RESET ALL DON AND DOFF  
LED.RUN  
LED.MANUAL  
LED.TUNE  
LED.RAMP  
LED.REMOTE  
LED.SP1/2

**Function state**

PID heating

PID cooling

PID zero

ON/OFF heating

ON/OFF cooling

ON/OFF zero

OR state active alarms)

AL1...AL4 (Alarm AL1...4 state)

LBA ALARM (LBA alarm state)

HB ALARM (HB alarm state)

LO ALARM (Low sensor input state)

HI ALARM (HIGH sensor input state)

ERR ALARM (Err sensor input state)

SBR (Sbr sensor input state)

STATUS AUTOMATIC

STATUS MANUAL

STATUS LOCAL

STATUS REMOTE

Controller models with programmer also have:

PROGRAMMER IN HBB ALARM

PROGRAMMER IN RUN

PROGRAMMER IN HOLD

PROGRAMMER IN READY

PROGRAMMER IN END

STEP EVENT 1

STEP EVENT 2

STEP EVENT 3

STEP EVENT 4

## 5. EXAMPLES AND APPLICATIVE NOTES

### 5.16.3. Programming Function Block

#### 5.16.3.1. Configuration page

The Function Blocks configuration page of the C-PWR program lets you configure and debug the Function Blocks.

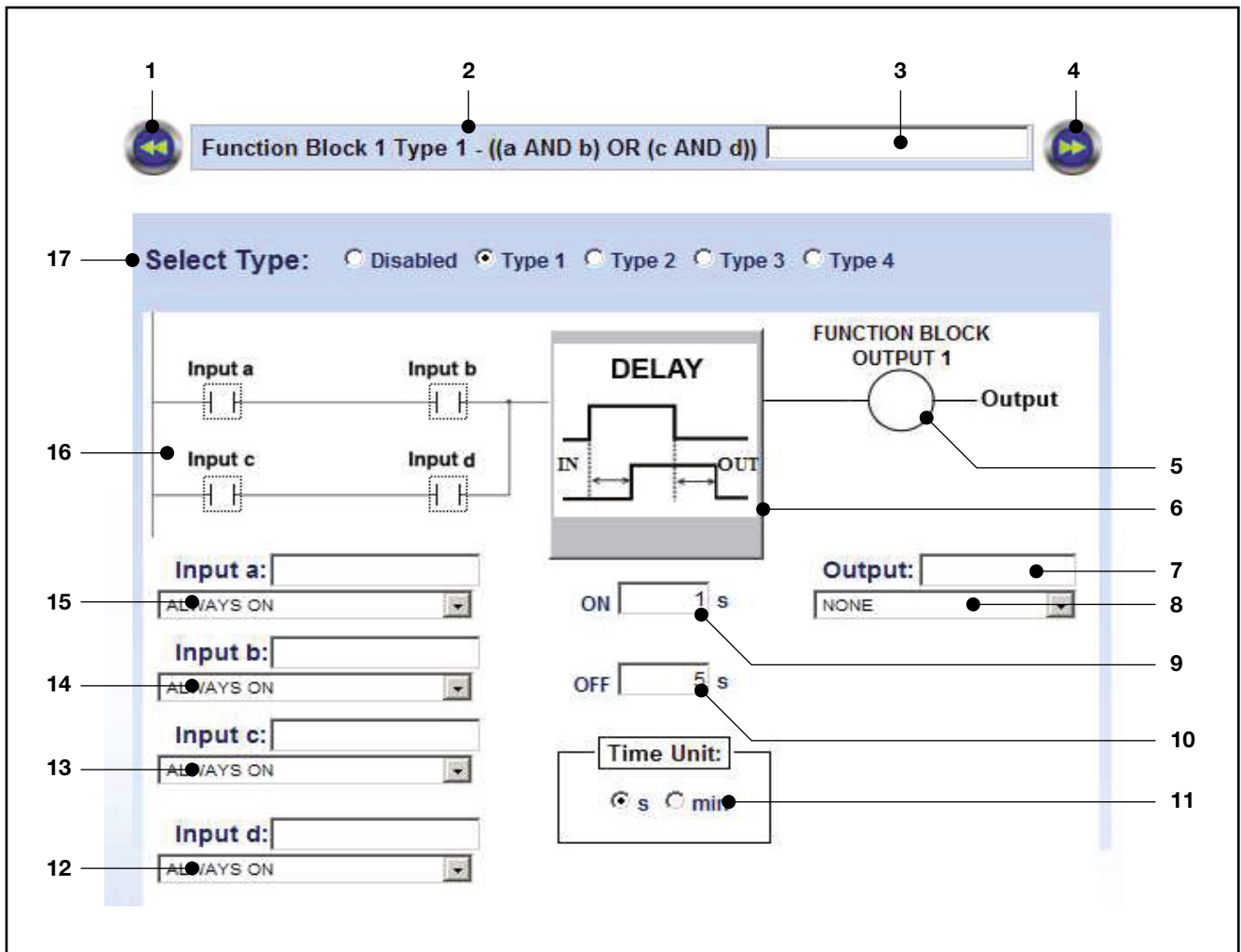

1. Button to return to previous function block.
2. Number of function block and type of logic operations run.
3. Name of function block. You can insert an optional descriptive name of the function block.
4. Button to go to next function block..
5. Output value when result of function operations is true.
6. Graph of DELAY TIMER.
7. Name of output. You can insert an optional descriptive name of the output.
8. Type or variable of activated output.
9. Duration of ON delay.
10. Duration of OFF delay.
11. Unit of measurement of delays (seconds or minutes).
12. Type or variable of input evaluated for input **d**.
13. Type or variable of input evaluated for input **c**.
14. Type or variable of input evaluated for input **b**. The Input d box is used to insert an optional descriptive name of input **b**.
15. Type or variable of input evaluated for input **a**. The Input a box is used to insert an optional descriptive name of input **a**.
16. Graph of logic operation run. The input boxes also show the value that the input must assume in order to be considered "true".
17. Selection of logic function applied to function block.

## 5. EXAMPLES AND APPLICATIVE NOTES

### 5.16.3.2. Enabling the function block and selecting the type of functional logic

The function block page is enabled automatically as soon as you select a type of functional logic. The page is not deleted if you select Disabled.

The configuration of inputs, output and delays stays saved in the software program.

When you select the type of functional logic assigned to the function block, its graph changes as well, as shown in the figures below.

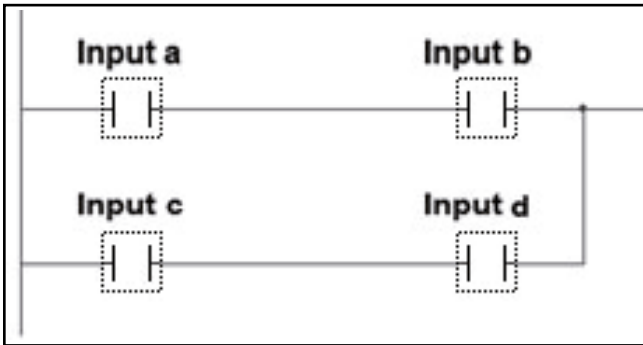

TYPE 1 - (a AND b) OR (c AND d)

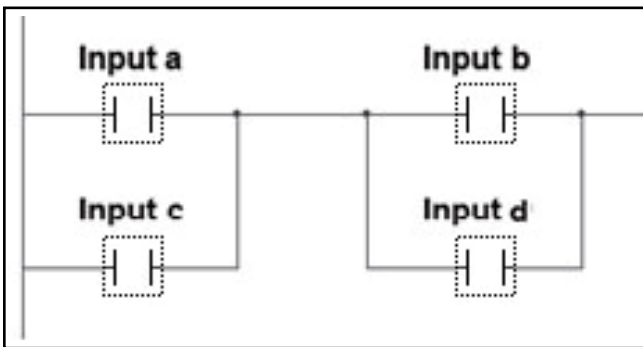

TYPE 2 - (a OR c) AND (b OR d)

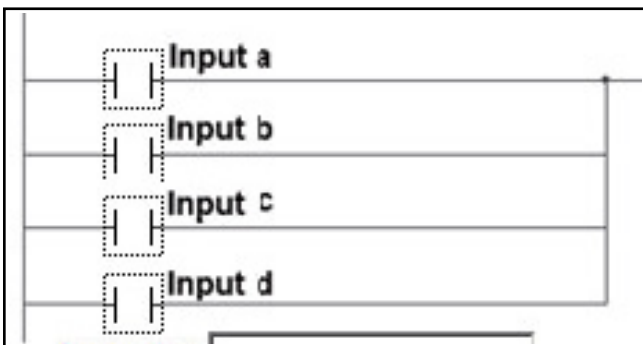

TYPE 3 - a OR b OR c OR d

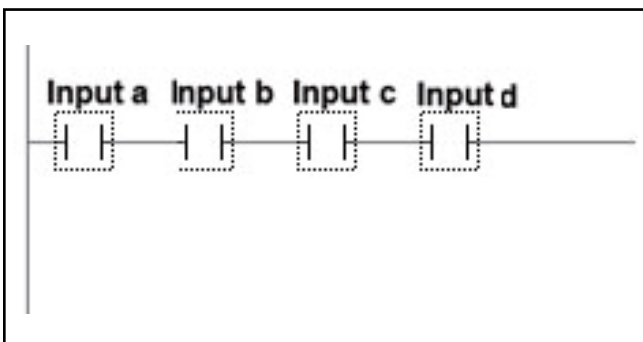

TYPE 4 - a AND b AND c AND d

Give a descriptive name to the function block so that it can be easily recognized for future use.

The name will be saved as part of the “configuration recipe” only on the PC. If you copy the configuration to other controllers, the controller to which the configuration is copied will not contain these descriptive names.

### 5.16.3.3. Configuring input variables

Configure the four input variables **a**, **b**, **c** and **d**, one at a time. On the pull-down menu, select the variable to be assigned to the input.

The options are:

- ON, input always ON;
- OFF, input always OFF;
- one of the values in the groups of Digital input state, Digital output state, and Function state variables listed above in paragraph “5.16.2. Groups of variables.””5.16.2. Groups of variables” on page 164.

By clicking the input’s icon you can reverse its reference state from normally open (NO) to normally closed (NC) and vice versa.

This cannot be done if you chose ON or OFF on the pull-down menu.



NO



NC

If digital inputs IN1, IN2, IN3, IN4, IN5 are among inputs **a**, **b**, **c** and **d**, and you want them to be used only in Function Blocks, you have to configure the function Func = FB.IN for them.

If you want to transmit the output state of a function block (FUNCTION BLOCK OUTPUT 1...16) to an output OUT1...OUT4 of the controller, you have to configure the function Func = FB.OUT for these outputs and specify the output number of the function block in FB.OU.N

Digital I/O assignment		
Input 1	Output 1	
F.IN_1: FB.IN	F.OU.R_1: FB.OUT	FB.OU.N_1: 1
Input 2	Output 2	
F.IN_2: FB.IN	F.OU.R_2: NONE	FB.OU.N_2: 0
Input 3	Output 3	
F.IN_3: NONE	F.OU.R_3: ALRM2	FB.OU.N_3: U
Input 4	Output 4	
F.IN_4: NONE	F.OU.R_4: ALRM2	FB.OU.N_4: 0
Input 5		
F.IN_5: NONE		

Complete the configuration by giving a descriptive name to each input so that it can be easily recognized for future use.

The name will be saved as part of the “configuration recipe” only on the PC and will not be transferred to the controller. Therefore, when the controllers are cloned, the controller to which the configuration was copied will not contain this descriptive name.

## 5. EXAMPLES AND APPLICATIVE NOTES

### 5.16.3.4. Configuring the output

Configure the output by selecting on the pull-down menu one of the values listed in the Function Commands group shown above in paragraph “5.16.2. Groups of variables.” This will be the output variable whose value will be changed by the result of the logic operation processed with the input variables data.

 If the function given the output of the function block is the same assigned to a digital input, the state of this input has priority.

By clicking the output’s icon you can reverse, from normally open (NO) to normally closed (NC) and vice versa, the transmitted state if the result of the logic operation is “true.”



End the configuration by giving a descriptive name to the output so that it can be easily recognized for future use.

The name will be saved as part of the “configuration recipe” only on the PC and will not be transferred to the controller. Therefore, when the controllers are cloned, the controller to which the configuration was copied will not contain this descriptive name.

### 5.16.3.5. Configuring delays

You can insert a delay between the result of the logic operation and the change in value of the output variable. These delays, which can differ from the “true” result and the “false” result of the logic operation, are set on the DELAY

TIMER.  
Delays can be counted in seconds or in minutes

Configure both delays:

- ON, which indicates how long after a “true” result of the logic operation the value of the output variable is changed.
- OFF, which indicates how long after a “false” result of the logic operation the value of the output variable is changed

When the time is set to 0 (zero), the change in value of the output variable is instantaneous.

If both delays for ON and OFF equal 0, the DELAY TIMER is ignored

The counter values that have passed and remain in the ON and OFF delay times are reported in the variables:

- E.ON.01 ... E.ON.16 (elapsed ON time)
- R.ON.01 ... R.ON.16 (remaining ON time)
- E.OF.01 ... E.OF.16 (elapsed OFF time)
- R.OF.01 ... R.OF.16 (remaining OFF time)

The setting of the ON and OFF delay times may be limited with the parameters:

- H.ON.01 ... H.ON.16 (ON delay time upper limit)
- H.OF.01 ... H.OF.16 (OFF delay time upper limit)

The setting of the delay times for ON (D.ON.01 ... D.ON.16) and OFF (D.OF.01 ... D.OF.16), the upper limits and the elapsed and remaining counts can be entered in the user menu.

## 5.17. Instrument menu set-up

The instrument set-up menu may be customised, selecting the menus and the parameters in each menu that must be visible or invisible while browsing with the keypad. For selecting the menus and menu parameters to be displayed in the instrument’s editor, there is a new button on the C-PWR WIZARD page (which may be called up using the “EN.EDI” parameter in the MODE menu):

This button opens a new window containing all the menus that may be displayed on the instrument



Select one of the n menus and another window will open permitting selection of individual menu parameters:

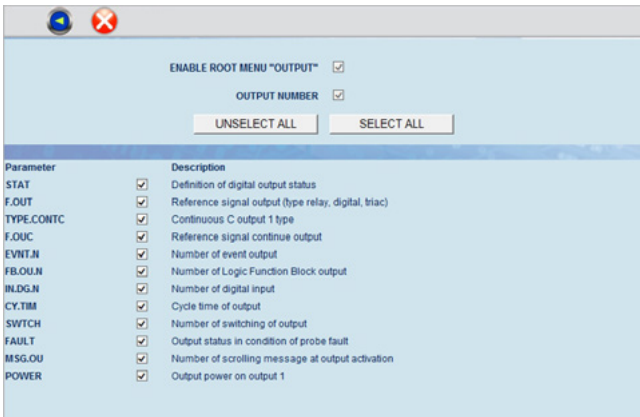

You may select / deselect all parameters at the same time with the "SELECT ALL" and "UNSELECT ALL" buttons. The "ROOT" and "NUMBER" checkboxes (the second only in the case of a menu with multiple instances, such as OUTPUT1, OUTPUT2, etc.) above these buttons cannot be selected by the user, but indicate the two editor views which are obligatory if there is at least one menu parameter selected.

PLEASE NOTE: the common parameters of the I.MAIN, I.SPR, I.CT1 and I.CT2 menus must be selected and follow the setting of the I.MAIN menu.

For example, if the HI.SCL parameter is deselected in the I.MAIN menu, the HI.SPR, HI.CT1 and HI.CT2 parameters will be automatically deselected. It is not possible to select the HI.SPR, HI.CT1 and HI.CT2 parameters from the I.SPR, I.CT1 and I.CT2 menus, except by acting on HI.SCL of I.MAIN.

The corresponding variables may be viewed in the EXPERT menu under the "Enable Menu" group

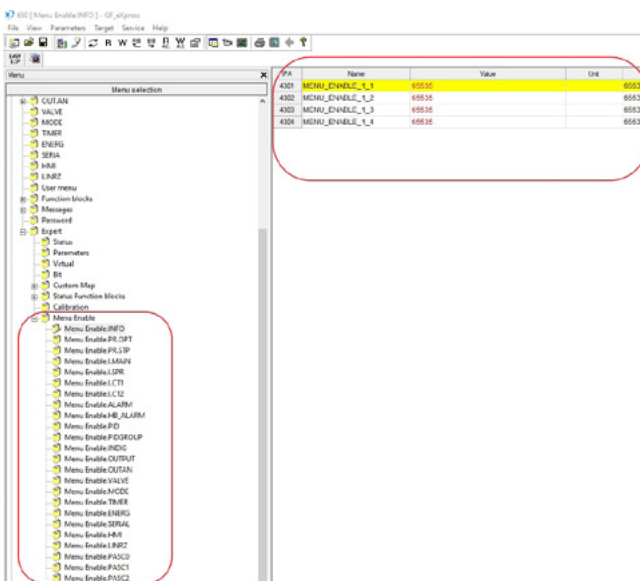



## 6. PROGRAMMING WITH PC

### 6.1. Controller-PC connection

The controller has a port to connect the device to a PC. The following photos show where the port is located on the different controller models.

The connection requires a special accessory cable (code F060800), which acts as a USB-serial interface/converter and communicates as a Virtual COM Port with a USB port on the computer.



**Attention!** To use this interface you have to install the VCP driver, downloadable from:

[www.chromalox.com](http://www.chromalox.com)

When the controller is connected to the PC you can configure it rapidly even when it is not powered.

The instrument configuration memory is powered by the USB connection.

Connecting the controller to the primary power supply while the USB cable is still connected DOES NOT activate normal Power-on. You must first disconnect the controller from the PC and then apply primary power.

### 6.2. Programming Tool

#### 6.2.1. C-PWR

The C-PWR software lets you:

- read and write the configuration of controller (set of parameters);
- save recipes on the PC (recipe archive);
- display as graph / set all parameters needed for the Programmer function;
- display/set Logic Operations (Function Blocks);
- set the user configuration menu sequence and parameters;
- set message strings (3 selectable languages);
- transfer any firmware updates.

#### 6.2.1.1. System requirements

	Minimum	Recommended
<b>Operating system</b>	Windows XP SP2 or Windows Vista or Windows 7 (32 bit)	Windows 7 (64 bit)
<b>Processor</b>	Intel Pentium 1 GHz	Intel Core i5 2,5 Ghz or higher
<b>RAM</b>	2 GB	4 GB or higher
<b>Free space on Hard Disk</b>	2 GB	4 GB or higher
<b>Resolution</b>	XGA (1024 x 768 pixel)	SXGA (1280 x 1024 pixel) or higher
<b>Browser</b>	Microsoft Internet Explorer 8.0	Microsoft Internet Explorer 9.0 or higher
<b>Ethernet port</b>	1 RJ45	1 RJ45
<b>DVD reader</b>	Yes	Yes
<b>USB port</b>	1 USB 2.0	1 USB 2.0



## 7. OPERATOR GUIDE

### 7.1. Displays and keys

The display and keys for each model are described in paragraphs “1.3.1. Display and keys” on page 13 for the 6140, and “1.5.1. Display and keys” on page 17 for the 4140.

#### 7.1.1. Navigating the menus

keys are used for navigating menus and submenus, changing parameters, and confirming choices. Their function depends on the context and on how long they are pressed.



The LEDs above the keys not only give confirmation that each key has been pressed (by flashing), but also show which keys can be used in each situation.

The following navigation functions are assigned to the keys:



Scroll User Configuration menu (Setpoint, Alarm setpoints, Control output, etc.).

Each time the key is pressed, it confirms the value of the displayed parameter and goes to the next item on the menu.

Keep the key pressed for more than 2 seconds to enter the Programming/Configuration Menu.



Each time the key is pressed, you go back to the previous menu item or to the higher menu level, according to the context.

Keep the key pressed for more than 2 seconds to return to the Home page.



Press the key to enter a submenu or to lower the displayed parameter value, according to the context. Keep the key pressed to progressively increase the speed of lowering the displayed parameter.



Press the key to raise the value of the displayed parameter.

Keep the key pressed to progressively increase the speed of raising the displayed parameter.

When the process variable is displayed, in standard configuration the  key switches the controller function mode (manual/automatic).

### 7.2. Power-on

The controller runs a self-diagnostics test immediately after power-on.

During the test all segments of the display flash and a checksum is run.

The hardware resources present are also acquired.

If the self-diagnostics test detects no errors, the controller enters normal functioning state (display shows Home page).

If any system errors are detected, the controller displays the related information.

If the error is caused by a damaged program, update the firmware.

If the error is caused by incorrect configuration, reconfigure the controller with PC and C-PWR software.

Errors are saved in a register and can be displayed with the Error function on the INFO menu.



### 7.3. Operation as controller

The device's normal operating mode is controller-only.

The display shows the following information:

- PV displays the process variable value;
- SV displays the setpoint value (if dS.Sp = setp);
- model 4140 also display the control output value (if dS.F = OUT.PW);
- by pressing the  key the PV display shows, in sequence the significant values that condition controller function: setpoint, alarm setpoints, control output, etc., which can be changed if necessary (parameters in the user menu).

Keep the  key pressed for more than 2 seconds to enter the Programming/Configuration menu.

Use the  and  keys to raise and lower the setpoint to the value required.

Press the  key to save the SP value; otherwise, the set value is saved about 15 seconds after the last change.

## 7. OPERATOR GUIDE

### 7.4. Operation as programmer

#### 7.4.1. Activating the programmer

To enable the Programmer function, set parameter PROGR = ON on the MODE menu.

On the user menu, the parameter P.STAT, which lets you display/control the programmer, is inserted by default. The user menu is available if QUICK = OFF

#### 7.4.2. Display messages

The different controller models display programmer state information in different ways.

The following examples show how the identical information is displayed on the 6140 and 4140 controllers.

As opposed to the model 6140, the 4140 also show the process variable PV value, and setpoint value of the active step.

1. Indication of programmer state. When on, the programmer is on.
2. Number of program running (in example: number 2).
3. Number of program step running (in example: number 5).
4. RUN LED: when on, indicates that program is running; when flashing, indicates that program is in STOP, END or HOLD and that time base is stopped.
5. RAMP LED: when on, indicates that programmer is running ramp segment of step; if off, it is in hold segment of step or at end of program (in example: running ramp of step 5).
6. Current time of segment (ramp or hold) of step. The time value depends on the set time base, hh:mm or mm:ss (in example: time lapsed is 20 minutes 42 seconds).
7. Process variable PV (in example: 118).
8. Setpoint of current step, i.e., value to be reached (in example: 120).

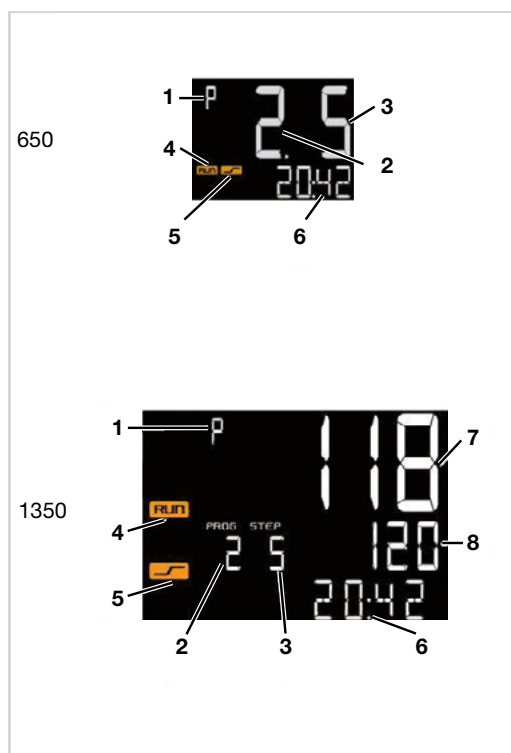

### 7.5. Errors during operation

If errors occur during normal operation, the display shows:

- the identifying code of the error on the PV display;
- the value of the setpoint or of the control output on the SV display.

If provided during configuration of the controller, a specific scrolling message appears on the SV display (model 6140) or on the F display (model 4140).

The most common error messages are:

- Lou** Process variable is below minimum scale limit (parameter LO.SCL on I.MAIN).
- High** Process variable is above maximum scale limit (parameter HI.SCL on I.MAIN).
- Err** PT100 in short circuit or input values below minimum limits (for example, thermocouple with incorrect connection) or 4...20 mA transmitter broken or not powered.
- Sbr** Sensor broken or input values above maximum limit.

## 7.6. Configuration (User menu)

Every operator has a freely accessible menu (no password required) on which he can configure some controller parameters.

The User Configuration menu can be built according to need with the C-PWR, grouping up to 50 parameters from those available for controller configuration (see chapter “4. Configuration” on page 43).

Among the parameters selected to build the menu of user configuration is PASS 1; it may be useful to submit a password to the parameters of the user menu.

In the example (p. 164) is indicated to impose on setting password PASS 1 setting alarms.

The controller leaves the factory with a preconfigured user configuration menu (shown below for model 6140-x-xxx-00000-x-xxx). This menu can subsequently be modified. The related parameters are shown for models with options; the complete list of parameters is shown on the C-PWR user menu page.

To access the User Configuration menu, simply press the **F** key. C-PWR can be used to set the generic parameter in the user menu to automatically return to Home if positioned on the parameter and no key is pressed within 15 seconds.

	Description	Unit of measurement	Valid values	Notes
	Local setpoint	scale points	LO.SP...HI.SP	
	Alarm 1 limit	scale points	LO.AL...HI.AL -999...999	If absolute alarm. If deviation alarm.
	Alarm 2 limit	scale points	LO.AL...HI.AL -999...999	If absolute alarm. If deviation alarm.
	Alarm 3 limit	scale points	LO.AL...HI.AL -999...999	If absolute alarm. If deviation alarm.
	Alarm 4 limit	scale points	LO.AL...HI.AL -999...999	If absolute alarm. If deviation alarm.
	Reset alarms latch and LBA alarm		Off On	Appears if at least one alarm with latch was set or if LBA alarm was enabled. The reset command is temporary and is not saved.
	Reset scrolling message		Off On	Appears if a scrolling message is present. The reset command is temporary and is not saved.
	Control output value		-100.0...100.0 On / OFF	Value Read Only
	Value manual power		0...100.0	The limit of setting depends on the type of control: 0...100.0% Heat control -100.0...100.0% Heat/Cool control
	Home page			

## 7. OPERATOR GUIDE

Example Menu user parameter PASS 1

Display / setting of alarm thresholds are subject to setting  
PASS 1

	Description	Unit of measurement	Valid values	Notes
	Local setpoint	punti scala	LO.SP...HI.SP	
	Insert password 1			
	If the password is correct you are in the menu, otherwise Home			
	Alarm 1 limit	scale points	LO.AL...HI.AL -999...999	If absolute alarm. If deviation alarm.
	Alarm 2 limit	scale points	LO.AL...HI.AL -999...999	If absolute alarm. If deviation alarm.
	Alarm 3 limit	scale points	LO.AL...HI.AL -999...999	If absolute alarm. If deviation alarm.
	Alarm 4 limit	scale points	LO.AL...HI.AL -999...999	If absolute alarm. If deviation alarm.
	Home page			

## 8. MAINTENANCE



**Attention!** The controller must be repaired only by technicians trained and authorized by Chromalox. Any attempt by unauthorized personnel to repair or change the hardware characteristics of the controller will void the warranty.

### 8.1. Replacing the controller

The instrument (display + electronic circuits) can be replaced without having to remove the entire controller from the panel and disconnect its cables.

First switch off the power supply to the controller and to the other devices connected to it.

Then release the top and bottom of the faceplate and remove the instrument (see figure).

Insert the new instrument and switch on the power supply.



**Attention!** Replace the entire controller if the blade contacts inside the instrument or the protective case show traces of burns or are not in perfect condition.

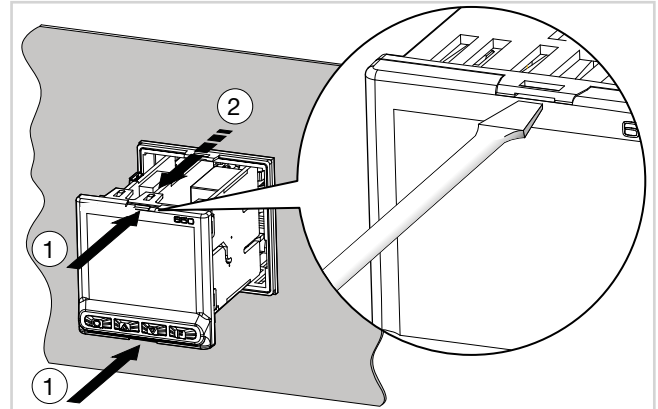

### 8.2. Replacing the gasket

The gasket may lose efficiency over time and due to environmental conditions.

To maintain IP65 faceplate protection, replace the gasket (between faceplate and case and between case and panel) at regular intervals.

To replace the gasket between the case and the panel you have to disassemble the controller from the panel and then reassemble it; to replace the gasket between the faceplate and the case, follow the instructions for replacing the controller).

### 8.3. Cloning the configuration

The configuration of one controller can be cloned to another controller by means of a PC or the optional ZAPPER accessory.

With a PC (and C-PWR software):

1. With the appropriate cable, connect the controller (with the configuration to be cloned) to the PC.
2. Read all of the controller configuration parameters and save them in a file (recipe).
3. Disconnect the controller.
4. Connect the controller to be configured to the PC.
5. Download the saved configuration to the controller.
6. Disconnect the configured controller

With the ZAPPER accessory:

1. Connect the ZAPPER to the controller with the configuration to be cloned.
2. Press the read key on the ZAPPER: the green LED starts flashing. DO NOT disconnect the ZAPPER while the LED is flashing.
3. After a short time the green LED lights up steadily. A rapidly flashing red LED means that the read procedure failed. Disconnect the controller.
4. Connect the ZAPPER to the controller to be configured.
5. Press the write key on the ZAPPER: the green LED starts flashing. DO NOT disconnect the ZAPPER while the LED is flashing.
6. After a short time the green LED lights up steadily. A rapidly flashing red LED means that the write procedure failed.
7. Disconnect the configured controller.

### 8.4. Cleaning

To clean the faceplate and the case, use only a soft cloth dampened with water or alcohol. DO NOT use hydrocarbon solvents (trichloroethylene, gasoline, etc.).

Do not use compressed air to remove dust from the electronic cards. If necessary, use a clean brush with soft bristles.

You can also clean the inside of the controller if necessary. To do this, first switch off the power supply to the controller and to the other devices connected to it.

Then slide out the controller as explained in paragraph "8.1. Replacing the controller" to access and clean the inside of the case "8.1. Replacing the controller" on page 177).

## 8. MAINTENANCE

---

### 8.5. Disposal

---



The controllers must be disposed of in conformity to current laws and regulations. If not correctly disposed of, some of the components used in the devices may harm the environment.



### 8.6. Troubleshooting

---

The following table shows the most common controller faults and their remedies.

Message or problem	Possible cause	Remedy

## 9. TECHNICAL DATA

OPERATOR INTERFACE		6140	4140
<b>DISPLAY</b>	Type	LCD black background	
	Screen area (L x H)	35×30 mm	83×68 mm
	Lighting	Backlit with LEDs, life > 40.000 hours @ 25 °C * with brightness level BACKL=0.8	
	PV Display	Number of digits: 4 to 7 segments, with decimal point	
		Digit height: 17 mm	Digit height: 23 mm
		Color: white	
	SV Display	Number of digits: 5 to 14 segments, with decimal point Digit height: 7,5 mm Color: green	Number of digits: 4 to 7 segments, with decimal point Digit height: 11 mm Color: green
	F Display		Number of digits: 7 to 14 segments, with decimal point Digit height: 9 mm Color: ambra
	Unit of measurement	Selectable, °C, °F or custom <sup>1</sup> Color: same as PV display	
	Controller state signals	Number: 6 (RUN, MAN, _/-, REM, SP1/2) Color: ambra	
Output state signals	Number: 4 (1, 2, 3, 4) Color: red		
Bargraph indicator, configurable		Type: graphic bargraph, 11 segments Power indication: 0...100% or -100...100% Current indication: 0...100% f.s. Valve position indication: 0...100%	
<b>KEYPAD</b>		Keys number: 4, silicone ( Man/Auto, INC,DEC,F) Type: mechanical	Keys number: 6, silicone Type: mechanical

1) Programming is done with the C-PWR configuration program.

## 9. TECHNICAL DATA

INPUTS		6140	4140
<b>MAIN INPUT</b>	Sensor type	TC, RTD (PT100, JPT100), infrared sensor (only for 4140), DC linear sensor	
	Accuracy	<b>TC inputs:</b> Calibration accuracy: < +/- (0,25% of reading value in °C +0,1°C) Linearization accuracy: 0,1% of reading value Cold junction accuracy: < +/- 1,5°C a 25°C room temperature) Cold junction compensation: > 30:1 rejection to the change of the room temperature <b>RTD input:</b> Calibration accuracy: < +/- (0,15% of reading value in °C +1°C) Temperature drift: < +/- (0,005% of reading value in °C +0,015°C)/°C from 25°C room temperature Linearization accuracy: 0,1% of reading value <b>Linear inputs:</b> Calibration accuracy:< 0,1% full scale Temperature drift: < +/- 0,005% full scale /°C at 25°C room temperature	
	Sampling time	60 ms / 120 ms, selectable	
	Digital filter	0,0...20,0 s	
	Temperature unit of measurement	Degrees C / F, selectable from keypad	
	Signal interval	Type: linear Scale: -1999...9999, settable decimal point	
	TC (thermocouple) input	Thermocouple: J, K, R, S, T, C, D, B, E, L, L-GOST, U, G, N, Pt20Rh-Pt40Rh Linearization: ITS90 or custom	
	RTD (resistance thermometer) input	Resistance thermometer: PT100, JPT100 Input impedance (Ri): ≥ 30 kΩ Linearization: DIN 43760 or custom Max. line resistance: 20 Ω	
DC linear input	0...60 mV	input impedance (Ri): > 70 kΩ	
	0...1 V	input impedance (Ri): > 15 kΩ	
	0...5 V / 0...10 V	input impedance (Ri): > 30 kΩ	
	0/4...20 mA	input impedance (Ri): 50 Ω	
		Linearization: linear or custom	
<b>AUXILIARY INPUT</b>	Remote setpoint	0...1 V, 0...10 V, 0/4...20 mA	
	Scale	0...1 V	input impedance (Ri): > 15 kΩ
		0...10 V	input impedance (Ri): > 30 kΩ
		0/4...20 mA	input impedance (Ri): 50 Ω
	Accuracy	0,1% f.s. ±1 digit @25 °C	
<b>CT (ammeter) INPUT</b>	Type	Isolated via external transformer	
		Number: 2 max Max. capacity: x / 50 mA AC Line frequency: 50/60 Hz Input impedance (Ri): 10 Ω	
	Accuracy	±2% f.s. ±1 digit @25 °C	
<b>DIGITAL INPUTS</b>	Type	voltage-free contact, or NPN 24 V - 4,5 mA, or PNP 12/24 V - max 3,6 mA (for detail see electrical connections)	
	Isolation	500 V	
	Number	3 max	5 max

OUTPUTS		6140	4140
	Relay (R)	Number: 4 max Type of relay contact: NO Max. current: 5 A, 250 VAC Minimum load: 5 V, 10 mA Life cycle: > 100.000 operations Double isolation	Number: 4 max Type of relay contact: NO Max. current: 5 A, 250 VAC / 30 VDC, $\cos\phi = 1$
	Logic (D)	Number: 2 max Type: for solid-state relays Voltage: 24 V $\pm 10\%$ (min 10 V @20 mA) Isolated from main input	
	Triac ( long life relè) (T)	Number: 1 max Load: resistive Voltage: 75...264 VAC Current max: 1 A Isolation 3 kV snubber circuit integrated zero crossing switching	
	Continuous (C)	Number: 1 max Current: 4...20 mA $R_{out} : < 500 \Omega$ Resolution: 12 bit Isolated from main input	
	Analog retransmission (A1)	Number: 1 max 0...10 V, max 20 mA, $R_{out} : > 500 \Omega$ 0...20 mA, 4...20 mA, $R_{out} : < 500 \Omega$ Resolution: 12 bit Isolated from main input	
<b>ALARMS</b>	Number of alarm functions	4 max, assignable to an output	
	Possible configurations	Maximum, minimum, symmetric, absolute/relative, exclusion at firing, memory, reset from keypad and/or contact, LBA, HB, HBB Hold Back Band if enabled with Programmer function	

## 9. TECHNICAL DATA

<b>CONTROL FUNCTIONS</b>		<b>6140</b>	<b>4140</b>
<b>CONTROL</b>	Type	Single loop	
	Control	PID, ON/OFF, single action heat or cool, double action heat/cool	
	Control output	Continuous or ON/OFF Cycle time: constant or optimized (BF)	
	Control output for motorized valves	OPEN/CLOSE for floating motorized valve on Relay, Solid-state, Triac outputs	
<b>SETPOINT PROGRAMMER</b>	Number of programs	Max 4 Start / Stop / Reset / Skip via digital inputs and/or outputs from logic operations Output state: Run /Hold / Ready / End	
	Number of steps	Max 32 freely selectable if in non-simplified mode: if in "Simplified programmer" mode, MAX 8 steps per program, with fixed order: Program 1, Step 1-8, Program 2, Step 9 – -16, and so on. Each with own setpoint, ramp time and hold time Times settable in HH:MM or MM:SS Max 4 consents, configurable for ramp and for hold Max 4 events, configurable in ramp and in hold	
<b>MULTIPLE SETPOINTS</b>	Number of setpoints	Max 4, selectable from digital input Each setpoint change is subject to set ramp, different for up and down ramp	
<b>LOGIC<sup>1</sup> OPERATIONS</b>	Function blocks	Max 16, with 4 input variables per block. The result can act on the state of the controller, of the programmer on alarms and outputs. Each function contains an incorporated timer block timer.	
<b>TIMER FUNCTION</b>	Modes	START / STOP STABILIZATION (timer is on when PV enters a band set around setpoint; at end of count you can activate an output, shut down SW or change SP1/SP2) FIRING (timed activation of control after power on)	
<b>ENERGY COUNTER</b>		Calculation done on nominal line voltage and nominal load power or on rms current measured on load via CT	
<b>DIAGNOSTIC</b>		Short circuit or open circuit (LBA alarm) Interrupted or partially interrupted load (HB alarm) Short circuit of control output (SSR alarm)	
<b>RETENTIVE MEMORY</b>	Type	EEPROM	
	Max. number of writes	1.000.000	
<b>SERIAL INTERFACE</b>		<b>6140</b>	<b>4140</b>
		Type: RS485 Baudrate: 1200, 2400, 4800, 9600, 19.200, 38.400, 57.600, 115.200 bit/s Protocoll: MODBUS RTU Isolated from main input	

1) Programming is done with the C-PWR configuration program.

## 9. TECHNICAL DATA

GENERAL DATA		6140	4140
POWER SUPPLY	Operating voltage	100...240 VAC/VDC $\pm$ 10%, 50/60 Hz (on request 20...27 VAC/VDC $\pm$ 10%)	
	Power dissipation	5 W max	10 W max
	Protections	Overvoltage 300 V / 35 V	
	Connection	Screw terminals and crimp connector, max. wire section 1 mm <sup>2</sup>	
CONNECTIONS	Serial configuration port (for USB connection)	Connector: microUSB	
	Inputs and outputs	Screw terminals and crimp connector, max. wire section 2,5 mm <sup>2</sup>	
AMBIENT CONDITIONS	Use	Indoor	
	Altitude	2000 m max	
	Operating temperature	-10 ... +55 °C (as per IEC 68-2-14)	
	Storage temperature	-20 ... +70 °C (as per IEC 68-2-14)	
	Relative humidity	20...85% RH non-condensing (as per IEC 68-2-3)	
PROTECTION LEVEL		IP 65 on front panel (as per IEC 68-2-3)	
ASSEMBLY	Positioning	On panel, removable faceplate	
	Installation regulations	Installation category: II; Pollution degree: 2 Isolation: double	
DIMENSIONS		48 × 48 mm (1/16 DIN), Depth: 80 mm	96 × 96 mm (1/4 DIN) Depth: 80 mm
WEIGHT		0,16 kg	0,24 kg
CE STANDARDS	EMC (electromagnetic compatibility)	Conforms to directive 2014/30/EU with reference to standard EN 61326-1 emission in industrial environment class A for models 650 LV emission in residential environment class B for models 650 HV	
	Safety LVD	conforms to directive 2014/35/EU with reference to standard EN61010-1	

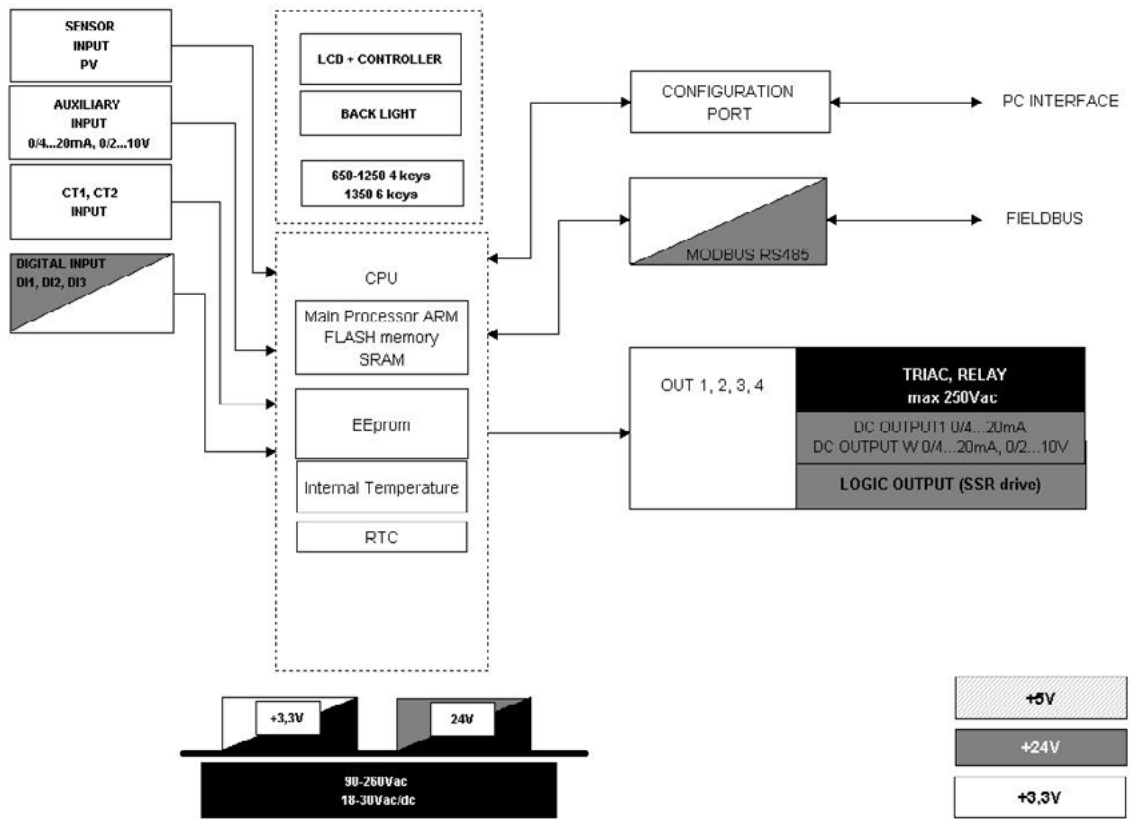

# 9. TECHNICAL DATA

## Insulation Block Diagram 6140

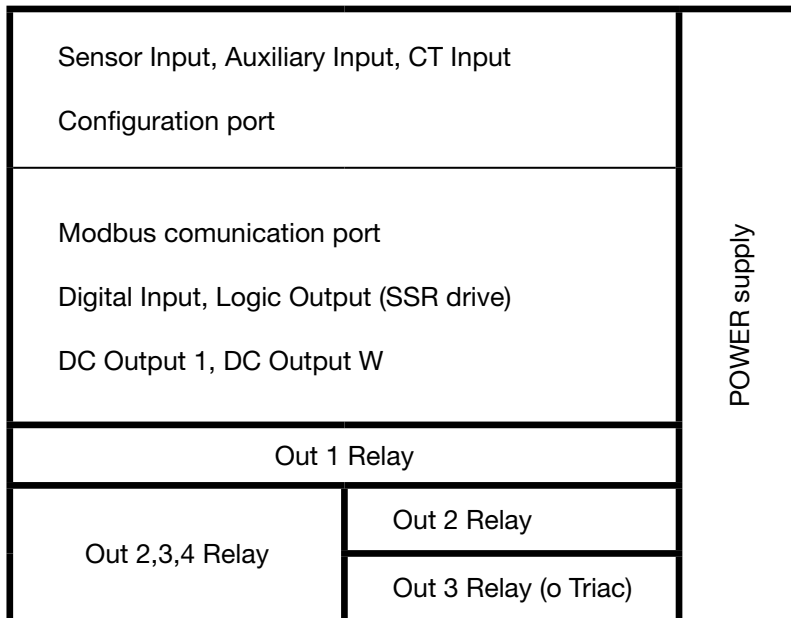

650

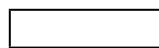

-  Functional insulation
-  Reinforced insulation

Insulation Block Diagram 4140

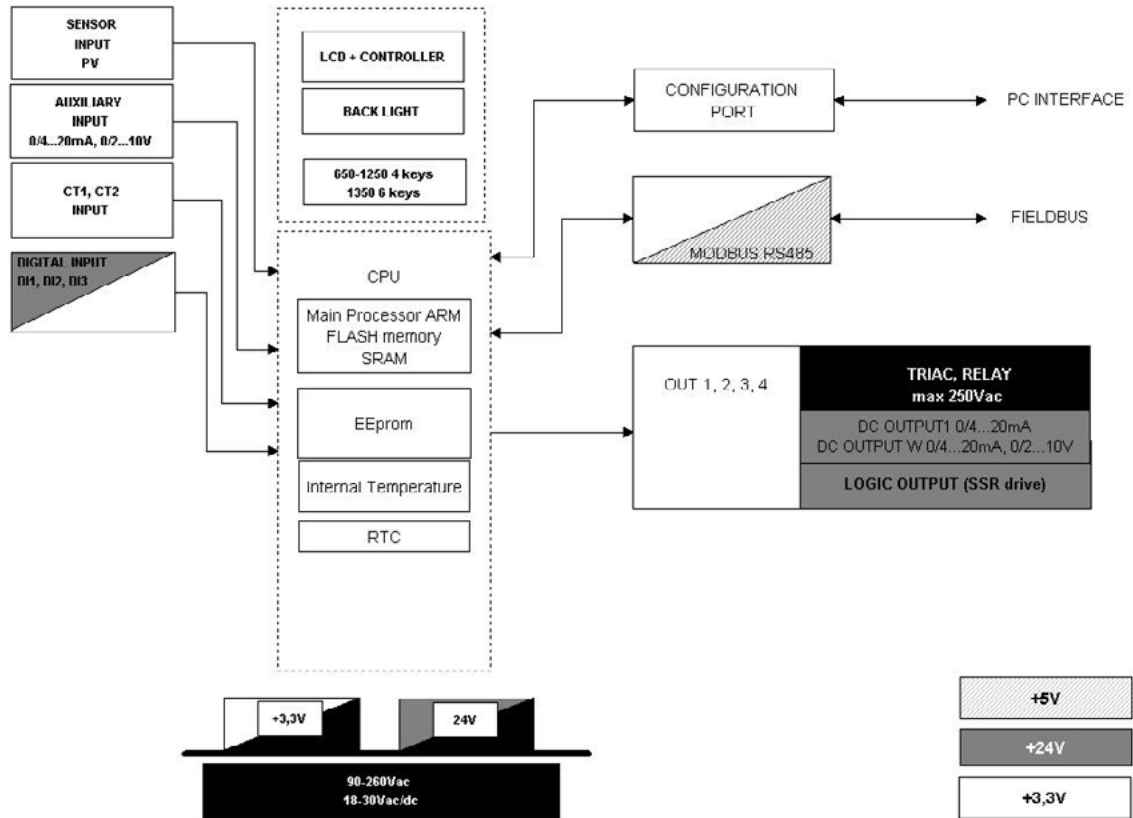

1250 1350

Sensor Input, Auxiliary Input, CT Input	POWER supply
Configuration port	
Modbus communication port	
Digital Input, Logic Output (SSR drive)	
DC Output 1, DC Output W	
Out 1 Relay	
Out 2 Relay	
Out 3 Relay (o Triac)	

- Functional insulation
- Reinforced insulation



# 10. ORDER METHODS

## 10.1. 6140 & 4140 Controller

6140 Standard Offering Order Table												
Power Supply Voltage	Model	Inputs			Outputs						Logic functions	Total Number of Outputs
		Digital	CT	Remote Set point	Relay	Triac	SSR Driver	Analog I	Analog Retrans	RS485		
100-240V	<b>6140-R-R00-00000-1-G</b>				2							2 outputs
20-27V	6140-D-R00-00000-0-G				1		1					
100-240V	<b>6140-D-R00-00000-1-G</b>				1		1					
20-27V	<b>6140-D-R00-00101-0-G</b>		1		1		1			•		
100-240V	6140-C-R00-00000-1-G				1			1				
20-27V	6140-C-R00-00101-0-G		1		1			1		•		
100-240V	6140-R-RR0-00000-1-G				3							3 outputs
100-240V	6140-R-RR0-00200-1-G		2		3							
100-240V	6140-C-RR0-00000-1-G				2			1				
100-240V	<b>6140-C-RR0-00101-1-G</b>		1		2			1		•		
100-240V	6140-C-DR0-00101-1-G		1		1		1	1		•		

**Bold Model Codes are Stocked**

4140 Standard Offering Order Table												
Power Supply Voltage	Model	Inputs			Outputs						Logic functions	Total Number of Outputs
		Digital	CT	Remote Set point	Relay	Triac	SSR Driver	Analog I	Analog Retrans	RS485		
100-240V	4140-R-R00-00000-1-G				2							2 outputs
100-240V	<b>4140-D-R00-00000-1-G</b>				1		1					
100-240V	4140-C-R00-10051-1-G	5		1	1			1		•		
100-240V	<b>4140-R-RR0-00000-1-G</b>				3							3 outputs
100-240V	4140-C-RR0-00000-1-G				2			1				
100-240V	4140-C-RR0-10051-1-G	5		1	2			1		•		
100-240V	4140-C-DR0-10050-1-G	5		1	1		1	1				
100-240V	4140-R-RR0-00000-1-G				3	1						4 outputs
100-240V	4140-C-DRR-00051-1-LFG	5			2		1	1		•	•	
100-240V	<b>4140-C-DRR-11251-1-G</b>	5	2	1	2		1	1	1	•		5 outputs

**Bold Model Codes are Stocked**

## 11. ACCESSORIES

Code	Description
0149-50200	Cable for programming with PC, USB-TTL 3 V with USB – microUSB connectors, length 1.8 m
0149-50201	Gasket for 6140
0149-50202	Gasket for 4140
0149-50203	Fastening Clip for 6140
0149-50204	Fastening Clip for 4140

**Limited Warranty:**

Please refer to the Chromalox limited warranty applicable to this product at  
<http://www.chromalox.com/customer-service/policies/termsofsale.aspx>.

**Chromalox, Inc.**  
**103 Gamma Drive**  
**Pittsburgh, PA 15238**  
**(412) 967-3800**  
**[www.chromalox.com](http://www.chromalox.com)**