

## Installation Instructions

# DIG Indicating Temperature Controller



PK607  
January, 2026

## General Information

### ⚠ CAUTION

**Chromalox DIG are designed for temperature control service only. Because they do not fail safe, they should not be used for temperature limiting duty.**

**APPLICATION** - Chromalox Type DIG SPDT thermostats are designed for a variety of applications where NEMA 4X enclosure are necessary or desirable. As well as precise temperature control.

### ⚠ CAUTION

**Chromalox DIG are not for use in hazardous environments as described in National Electrical Code. Failure to comply can result in explosion or fire.**

### ⚠ CAUTION

**Users should install adequate controls and safety devices with their electric heating equipment. Where consequences of failure may be severe, back-up controls are essential. Although the safety of the installation is the responsibility of the user, Chromalox will be glad to make equipment recommendations.**

The DIG indicating electronic temperature controller is very accurate and can be used to control heating and/or cooling equipment. The thermostat has a 8' waterproof temperature sensor which allows you to control temperatures remotely, and it retains settings in memory in case of power failure. Temperature is shown on the digital display when thermostat is on, and can be easily adjusted.

### ⚠ WARNING

**Use on AC only. Thermostat is not DC rated. Nominal Voltage range is 100-277VAC.**

#### OPTIONAL ACCESSORY

A bulb well with NPT connection is available through Chromalox. See the specifications on our Catalog Page for details and ordering information.

#### Bulb Wells

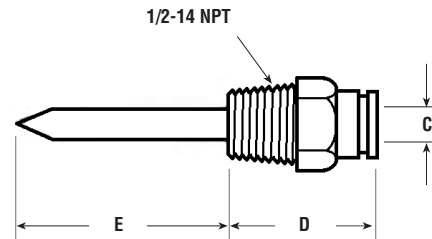

| Well Material | Dimensions (In.) |         |       |       |
|---------------|------------------|---------|-------|-------|
|               | C                | D       | E     | I.D.  |
| Copper        | 0.386            | 2-13/16 | 2.723 | 0.290 |

# DIG Non-Indicating Temperature Controller

## Installation Instructions

| Model Number | Temp. Range  | Sensor       |                  | Nominal Differential |
|--------------|--------------|--------------|------------------|----------------------|
|              |              | Dia.         | Length           |                      |
| DIG-25       | -30 to 220°F | 0.354" / 9mm | 2.565" / 65.16mm | 1-15°F               |

### Electrical Ratings

|  |     |     |     |     |
|--|-----|-----|-----|-----|
| Voltage, A.C. Only   | 120 | 208 | 240 | 277 |
| Non-Inductive or Resistance Load Amperes (Not Lamp Loads)                          | 30  | 30  | 30  | 30  |
| Pilot Duty - 125 VA, 24/600V. A.C.   |     |     |     |     |
| Electrical Endurance: 100,000 Operations (NO: 30A 240VAC, Room temp, 1s on 9s off) |     |     |     |     |

Mounting holes are  $\text{Ø}0.181"$  (4.6mm)

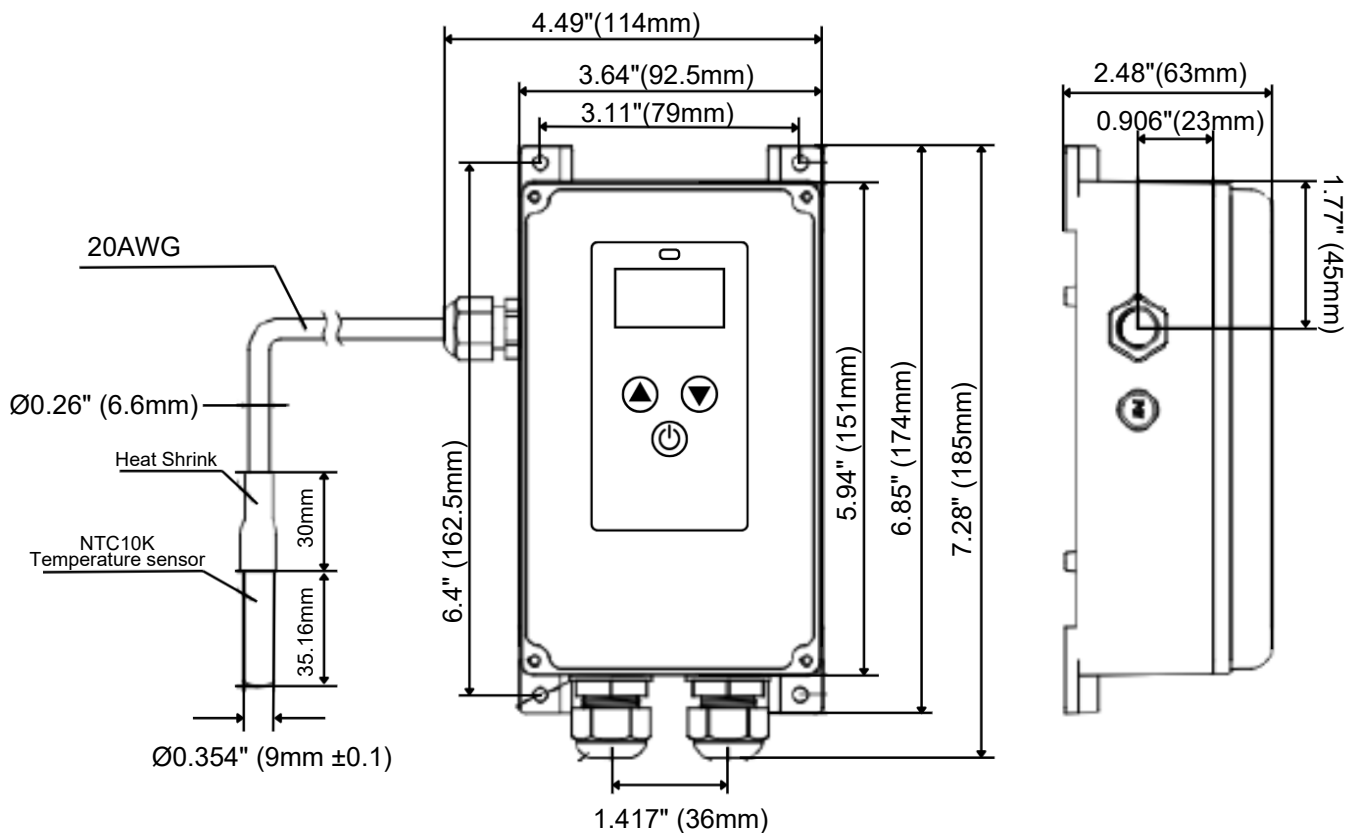

## Mounting

### ⚠ CAUTION

**Do not mount control where it will be subject to vibration, shock, grease, or corrosive vapors. Do not mount adjacent to a large magnetic contactor, as vibration and shock will cause thermostat to interact erratically - resulting in chattering of the contactor.**

The air temperature in and around the control enclosure should be kept as near to normal room temperature as possible. NEVER above 140°F or below -20°F.

Indoors, the thermostats may be mounted in any position.

Outdoors, where exposed directly to weather, the electrical connection should face down.

### Buttons

"▲": Increase parameter (Temperature or Differential)

"▼": Decrease parameter (Temperature or Differential)

"⏻": Power on and off by quick press. Access differential by holding for 3 seconds with power off.

### Temperature Setting

The DIG is default factory set at 68°F. When the Thermostat is on, the temperature setting may be adjusted by pressing button "▲" or "▼" which will adjust the variable by 0.5°F increments. Holding down both "⏻" and "▼" will allow you to cycle between Fahrenheit and Celsius.

### Differential Setting

The DIG is default factory set at 1°F. With the power off, press and hold "⏻" for 3 seconds, the differential setting will then be displayed. User can now adjust by pressing button "▲" or "▼" which will adjust the variable by 1°F increments.

Differential settings will be saved after 3 seconds of no buttons being pressed.

### Setting Protection

Settings will be saved when powered off, and recovered when powered back on.

### Fault Indication

In the case of a malfunction, the screen will display E0 and the output will be shutdown. The fault should be eliminated after the thermostat is turned off and then on again.

Screen will display LESS if the sensed temperature is less than the range of the thermostat.

## Lock/Unlock

The DIG is default factory set at unlock. When the Thermostat is powered on, the lock mode may be adjusted by holding down both the "▲" and "▼" arrows for 5 seconds which will then allow the selection of uL(unlocked) or L(locked) using the arrow keys.

After no operation for about 3 seconds, the setting will be saved automatically, and the unit will return to the normal display.

## Wiring

### ⚠ WARNING

**HAZARD OF ELECTRIC SHOCK. Disconnect all power before wiring or servicing this control. Failure to comply can result in electrical shock or electrocution.**

There are a two conduit openings on the NEMA 4X enclosure for easier installation. To make your wiring connections, proceed as follows:

1. Loosen the four cover screws and remove the cover. Do not damage the o-ring seal.
2. Insert wire through conduit opening and tighten conduit nut when in place.
3. Make wiring connections to the screw terminals. (The following is based on 120V 1PH)

Wiring when load does not exceed t'stat rating

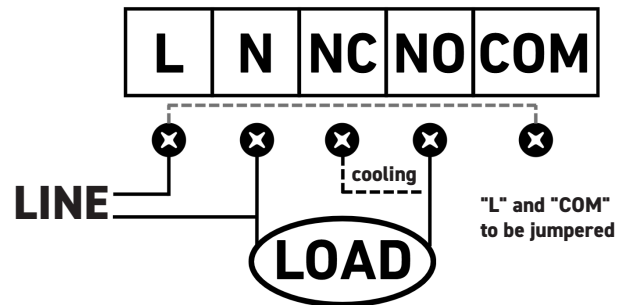

Wiring when load exceeds t'stat rating, pilot duty

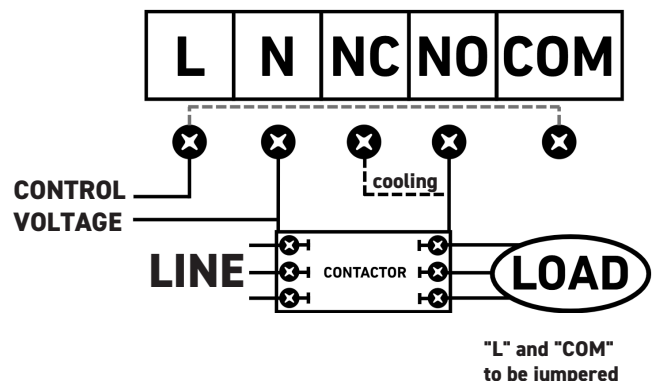

4. Replace the cover ensuring the o-ring seal is properly seated and tighten the screws.

**Limited Warranty:**

Please refer to the Chromalox limited warranty applicable to this product at  
<http://www.chromalox.com/customer-service/policies/termsofsale.aspx>.

**Chromalox, Inc.**  
**1347 Heil Quaker Boulevard**  
**Lavergne, TN 37086**  
**(615) 793**  
**[www.chromalox.com](http://www.chromalox.com)**