

Installation Instructions

CET-GF

for use with Self-Regulating & Constant Wattage
Electric Heating Cables



PJ971
161-562581-344
March, 2025

CET-GF

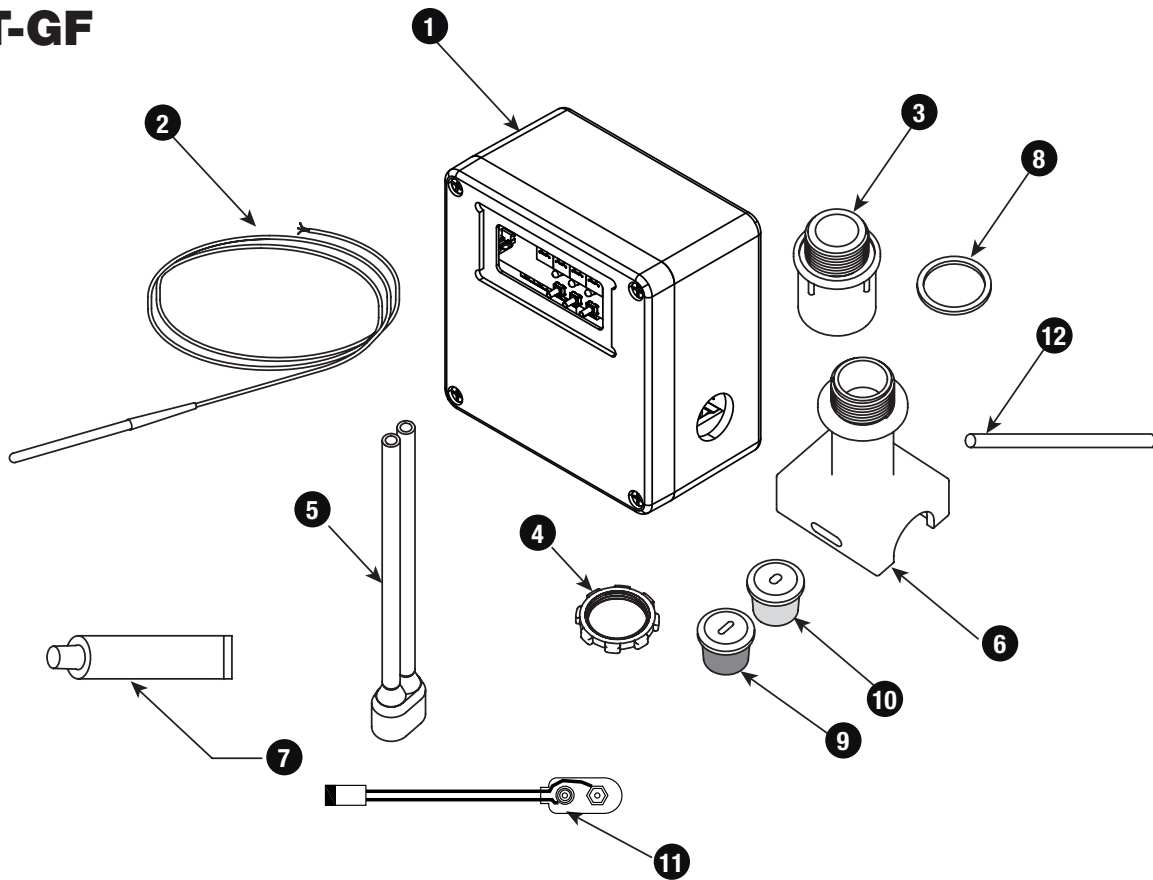

Item	Qty	Description	Item	Qty	Description
1	1	Control Unit / Junction Box	7	1	RTV
2	1	Line/Ambient Sensing RTD	8	1	O-Ring
3	1	Compression Fitting	9	1	Self-Regulating Cable Grommet
4	1	Locknut	10	1	Constant Wattage Cable Grommet
5	1	Silicone Termination Boot	11	1	9 VDC Battery Connector
6	1	Pipe Standoff	12	1	Protective Sleeve

General

The CET-GF unit is used for temperature control and electrical termination of self-regulating and constant wattage electric heating cables. Each kit contains the terminations needed to make all electrical connections.

The CET-GF digital thermostat kit is a microprocessor based temperature control and power connection kit used for freeze protection or process temperature maintenance of pipes protected by heat tracing products. This thermostat can be used in ordinary areas.

Certifications & Approvals



Precautions & Warnings

General Equipment Warnings

The user must ensure that their employees are fully trained and supervised in the proper working procedures in order to ensure their safety. The plant must be maintained in a safe condition.

Personnel must be fully aware of the risk associated with electricity. Only qualified personnel shall perform work on this unit during installation, operation, and maintenance procedures.

This equipment was specifically designed for its intended purpose and shall not be used for any other application without a complete re-evaluation by the manufacturer. The operator shall ensure these instructions are kept with the equipment to prevent any misuse for which the equipment has not been designed.



The Safety Alert Symbol  is used on the product, consult the documentation to find out the nature of the potential hazard, any actions to be taken, and the consequences of not adhering to the requirement.

The seriousness of the potential hazard is identified by one of three signal words below.



The Safety Alert Symbol  is used on the product, consult the documentation to find out the nature of the potential electrical hazard, any actions to be taken, and the consequences of not adhering to the requirement.

The seriousness of the potential hazard is identified by one of three signal words below.

Electrical Safety

All personnel working on electrical equipment shall strictly adhere to the applicable local, countrywide, and industry-recognized standards. Examples of such standards may include, but not limited to, the IEC (International Electric Code), NEC (National Electric Code), OSHA (Occupational Safety and Health Administration), NFPA (National Fire Protection Association), Health and Safety Work Act 1974, Factories Act 1961, and others. Failure to adhere to proper safety standards, including proper use of PPE (Personal Protective Equipment) may result in injury or even death. Chromalox will not be liable for failure of customer to adhere to governing standards.



DANGER – will result in serious injury or death.



WARNING – could result in serious injury or death.



CAUTION – may result in minor or moderate injury.



Means Protective Earth (ground) terminal. De-energize all equipment before opening junction boxes and control panels and follow the appropriate lockout/tagout procedures. Do not work on live circuits. Qualified persons and associated equipment must be effectively grounded in accordance with the applicable governing standard, such as the IEC (International Electric Code) to eliminate shock hazard. During any service work, please follow the proper electrical isolation, lockout/tagout, and disconnection procedures.

General Warnings

DANGER/DANGER

EXPLOSION HAZARD. Explosion could occur if this product is installed in a location in an environment it is not designed for. Ensure environmental rating is appropriate for the product.

Risque d'explosion. Une explosion peut se produire si ce produit est installé à un endroit dans un environnement pour lequel il n'a pas été conçu. Assurez-vous que la classification environnementale est appropriée pour le produit.

DANGER/DANGER

Hazardous voltage enclosed. Contact will cause electric shock and burn. Isolate all sources of power before removing the inner cover.

Tension dangereuse à l'intérieur. Tout contact peut provoquer une décharge électrique et des brûlures. Ne faites pas fonctionner le thermostat si le couvercle est fissuré, brisé ou inégal avec le boîtier.

CAUTION/MISE EN GARDE

EQUIPMENT DAMAGE. Users should install adequate controls and safety devices with their electric heating equipment. The consequences of all possible failure modes must be evaluated.

Domages matériels. Les utilisateurs doivent installer des contrôles et des dispositifs de sécurité adéquats avec leur équipement de chauffage électrique. Les conséquences de tous les modes de défaillance possibles doivent être évaluées.

CAUTION/MISE EN GARDE

EQUIPMENT DAMAGE. Equipment can be damaged by the ingress of water. Care must be taken to ensure that water does not enter the enclosure when covers are removed.

Domages à l'équipement. L'équipement peut être endommagé par la pénétration d'eau. Il faut veiller à ce que l'eau ne pénètre pas dans le boîtier lorsque les couvercles sont retirés.

NOTICE/AVIS

All personnel working on electrical equipment must adhere to all national and local regulations, codes, and standards.

Tout le personnel travaillant sur des équipements électriques à basse tension doit se conformer à toutes les réglementations, codes et normes nationales et locales.

NOTICE/AVIS

Only suitably qualified and experienced persons, who are familiar with this equipment, and the work they are to do, should carry out installation, commissioning, operation, or maintenance of this equipment.

l'installation, la mise en service, le fonctionnement ou l'entretien de cet équipement ne doivent être effectués que par des personnes qualifiées et expérimentées, déjà familiarisées avec cet équipement et le travail qu'elles doivent faire.

NOTICE/AVIS

Such persons shall adhere to proper electrical safety procedures, including the use of appropriate personal protective equipment (ppe).

Ces personnes doivent respecter les procédures de sécurité électrique appropriées, y compris l'utilisation d'un équipement de protection individuelle (epi) adéquat.

NOTICE/AVIS

Failure to adhere to any of the above may result in equipment damage, operating losses, injury, or death. Chromalox will not be liable for failure to adhere to all governing regulations, codes, standards, site procedures and information given in this manual.

Le non-respect de l'une des consignes ci-dessus peut entraîner des dommages matériels, des pertes d'exploitation, des blessures ou la mort. chromalox ne sera pas responsable du non-respect de toutes les réglementations, codes, normes, procédures de site et informations données dans ce manuel.

NOTICE/AVIS

**If in doubt, contact chromalox.
En cas de doute, contactez chromalox.**

NOTICE/AVIS

When the outer cover is removed, the enclosure ingress protection is reduced to NEMA 1 [IP 20]. With the inner cover still in place, the enclosure is finger proof, but not water resistant, or proof against tools and wires.

Lorsque le couvercle extérieur est retiré, la protection contre les intrusions du boîtier est réduite à NEMA 1 [IP 20]. Avec le couvercle intérieur toujours en place, le boîtier est à l'épreuve des doigts, mais il n'est pas à l'épreuve de l'eau, ni des outils et du câblage.



NOTICE/AVIS

Tools should not be used to depress the push-buttons on the inner cover.

Il ne faut pas utiliser d'outils pour appuyer sur les boutons-poussoirs du couvercle intérieur.



NOTICE/AVIS

If the equipment is used in a manner not specified by the manufacturer, then the protection provided by the equipment may be impaired.

Si l'équipement est utilisé d'une manière non spécifiée par le fabricant, la protection fournie par l'équipement peut être altérée.



NOTICE/AVIS

If the equipment is used in a manner not specified by the manufacturer, then the warranty will be invalidated.

Si l'équipement est utilisé d'une manière non spécifiée par le fabricant, la protection fournie par l'équipement peut être altérée.

Receiving, Handling, & Lifting



The packaging supplied is only suitable for short term indoor storage.

Any outdoor storage is considered temporary (less than 48 hours) and the entire system must immediately be protected from the outdoor elements with appropriate coverings. The coverings shall be suitably covered for protection against adverse weather, using a tear-free waterproof membrane such as a tarpaulin. The equipment shall be placed on dry ground or on blocks to lift it clear of any possible water.

The unit must be handled with care and stored in clean, dry conditions as befits any electrical apparatus. Units must not be exposed to wet or damp atmospheres. Units shall be stored in areas with uniform temperature control to prevent condensation accumulation.

Unpacking

All hardware and materials are to be removed with tools designed for the purpose.

Equipment Handling & Lifting

Ensure that the equipment is correctly moved and installed by technically qualified and competent persons experienced in the class of work involved. Know the capabilities of the lifting equipment available to handle the weight of the system. At no time should any person be under, or in contact with, a suspended load.

Ensure that all precautions are taken regarding the weight of the panel or controller. Lifting equipment shall have capacity for the given weight.

Exercise care during any movement and placement operations to prevent falling or unintentional rolling or tipping.

Each unit is manufactured with great care from the highest quality materials and thoroughly inspected before leaving the manufacturing facility. Examine the equipment against the packing list to check that the quantity received, and its identity is complete.

Start-up & Commissioning

Installation review, Start-up, and Commissioning shall only be performed by Chromalox personnel. Otherwise, the User assumes all responsibilities, and all warranties, both written and implied, are voided otherwise.

Contact Chromalox Service Group or www.chromalox.com for additional information.

Check that labels and tags are secure and correct.

Ensure all other safety and / or shutdown devices are functioning properly.

It is a warranty requirement to comply with these instructions and documented evidence shall be maintained in the form of a signed checklist as per the Appendix A or operator's equivalent.

NOTE: A completed Maintenance Checklist or equivalent will be required in the event of any safety or warranty claim.



NOTICE/AVIS

Inspect the equipment/system to ensure no damage has occurred within 48 hours of receipt. If damaged, please report any claims to your carrier and contact Chromalox within 7 days for repair options. Do not attempt to operate damaged equipment.

Inspectez l'équipement/le système pour vous assurer qu'aucun dommage n'est survenu dans les 48 heures suivant la réception. En cas de dommage, veuillez signaler toute réclamation à votre transporteur et contacter Chromalox dans les 7 jours pour connaître les possibilités de réparation. N'essayez pas de faire fonctionner un équipement endommagé.

Any service work must be performed by trained personnel.

Contact your local Chromalox representative for technical support. Provide your unit part number, model number, and Chromalox purchase order number to properly identify the equipment.

Cable installation instructions: CPR, CPM, CZH cable special instructions denoted by *

WARNING: For pipe temperatures over 500°F (260°C) or use with MI cable, use High Temp Adapter Kit

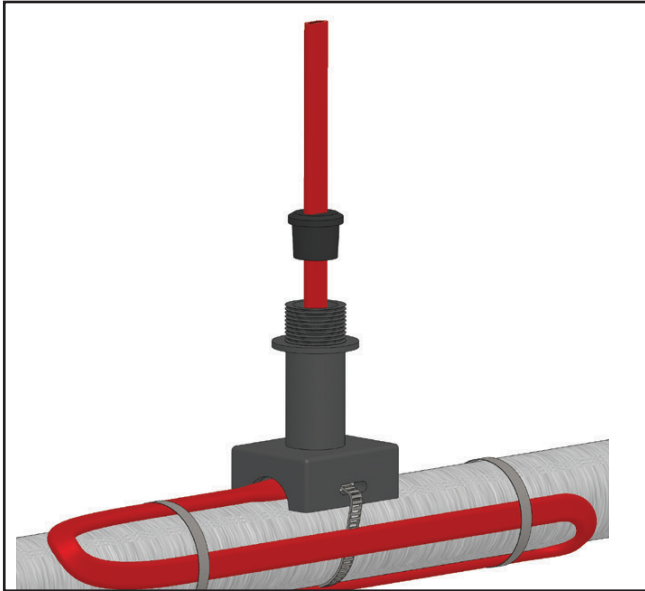

1. Insert heating cable through pipe standoff and proper grommet as shown. 8 inches of cable should extend past the grommet. Strap pipe standoff to pipe with pipe strap (Chromalox type PS not included) and attach extra cable to pipe as appropriate. If the provided RTD is to be fed through the standoff pipe, a small slice will need to be made to the outer edge of the top of the grommet. For pipes smaller than 1-1/2" diameter a small pipe adapter (Chromalox model SPA not included) is required.

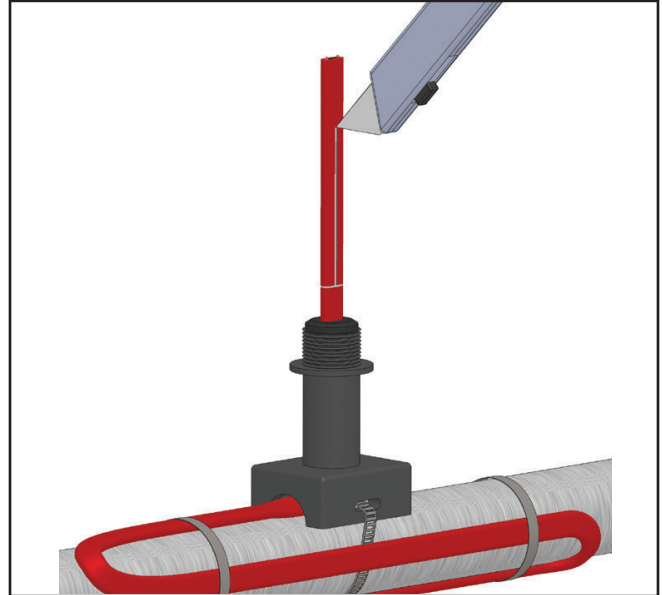

2. Score the outer insulation 7 inches from the end of the cable. Lightly cut the outer jacket up the center to the end of heating cable and remove the outer jacket from the cable. **WARNING: DO NOT CUT METAL BRAID.**

Note: If using over braid only cable, skip this step.

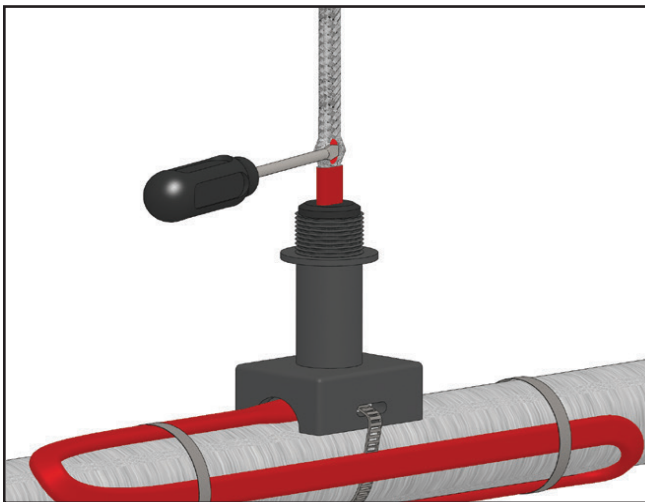

3. Move braid back toward the overjacket, creating a bulge. At the bulge, separate the braid to make an opening.

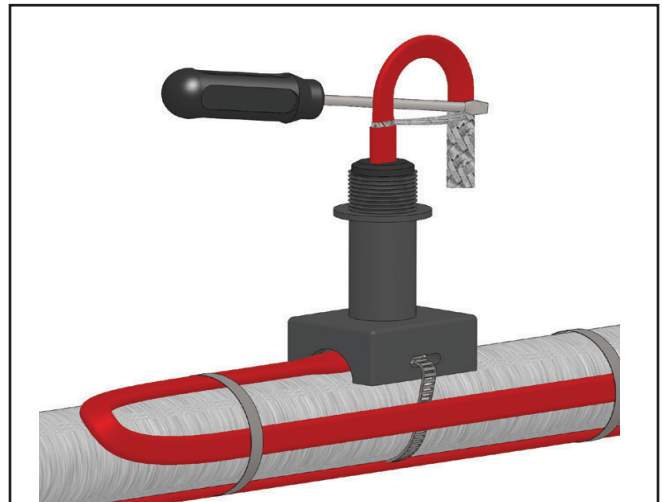

4. While bending the heating cable, work the cable through the braid opening. Pull the braid tight.

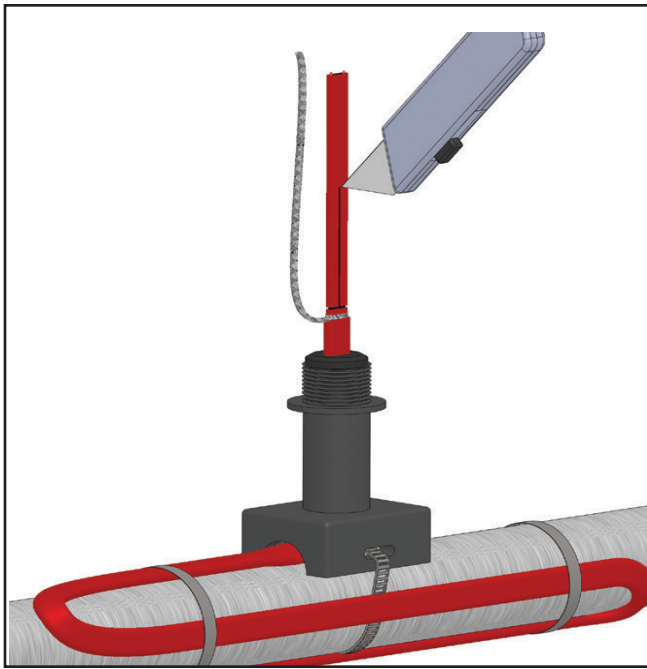

5. Score the inner insulation 6 inches from the end. Lightly cut the inner jacket up the center to end of heating cable and remove the inner jacket from the cable.

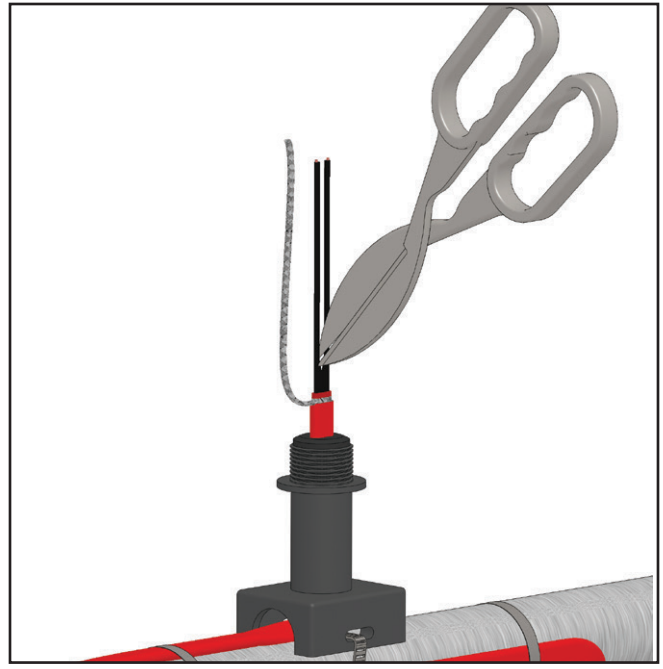

6. Use tin snips or similar tool to cut excess material from between the buss wires.
*Separate CZH leads and strip 1/4" from each lead wire.

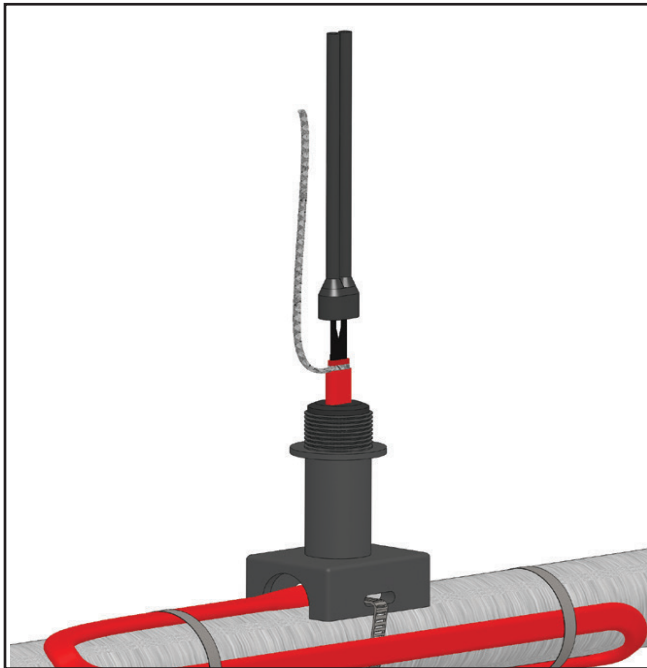

7. Liberally apply RTV over the exposed matrix and leads. Push the rubber boot over the heating cable.

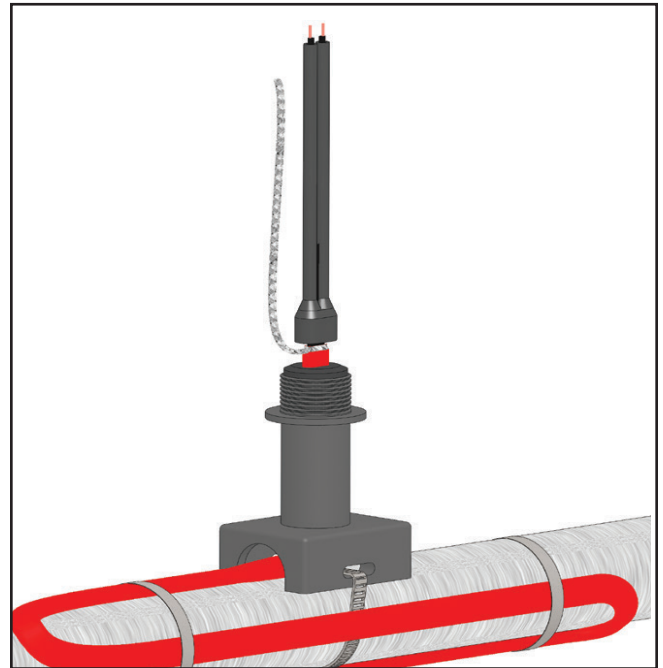

8. Strip each bus wire so that no black matrix material shows above the end of the rubber boot. Trim lead ends as needed.

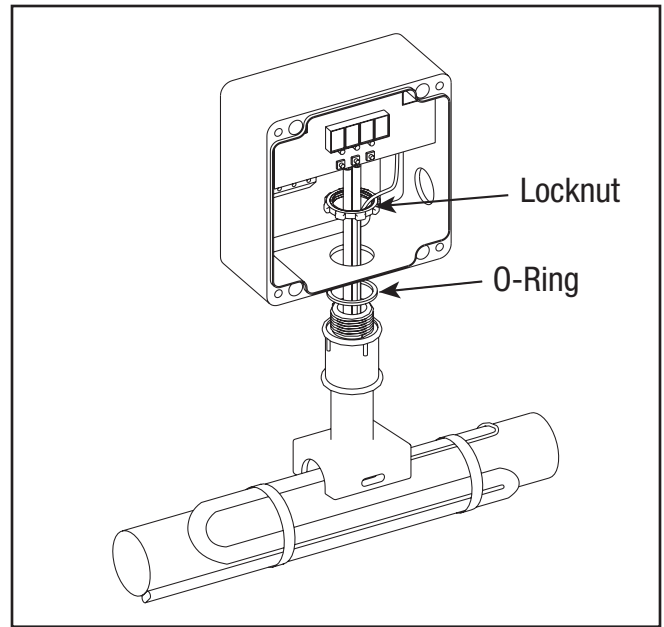
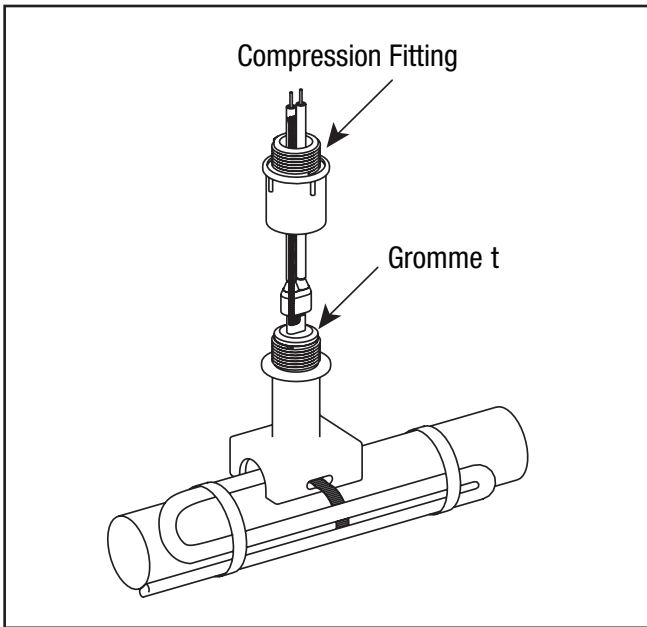

9. Slide compression fitting over cable. Grommet should be placed inside pipe standoff. Termination boot should be spaced 1/2" from sealing grommet. Tighten compression fitting until it bottoms out against pipe standoff.

10. Seat O-Ring into compression fitting groove at base of threads. Ensure O-Ring is not twisted. Assemble junction box to compression fitting as shown. Tighten locknut until the junction box bottoms out against the lip of the compression fitting.

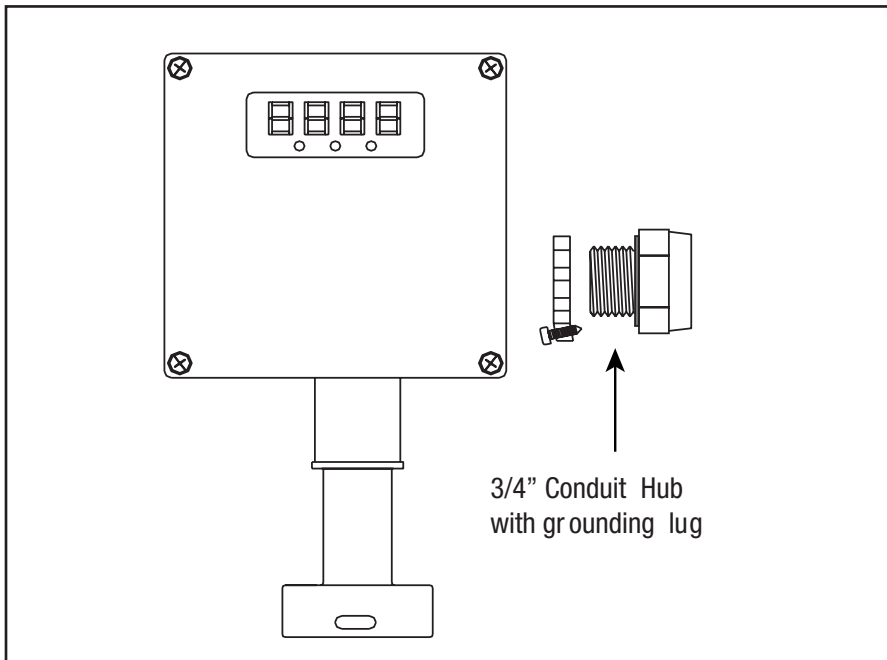

11. Please see the electric diagram for proper wiring for your application. For over-jacketed cable with internally grounded braid: Grounding braid shall have the included protective sleeve slid over it once inside the enclosure. Then, insert grounding braid into grounding terminal. Attach junction box cover to seal enclosure. Access hole on right is designed for a 3/4" conduit hub. Use properly rated conduit hub to maintain NEMA 4X rating.

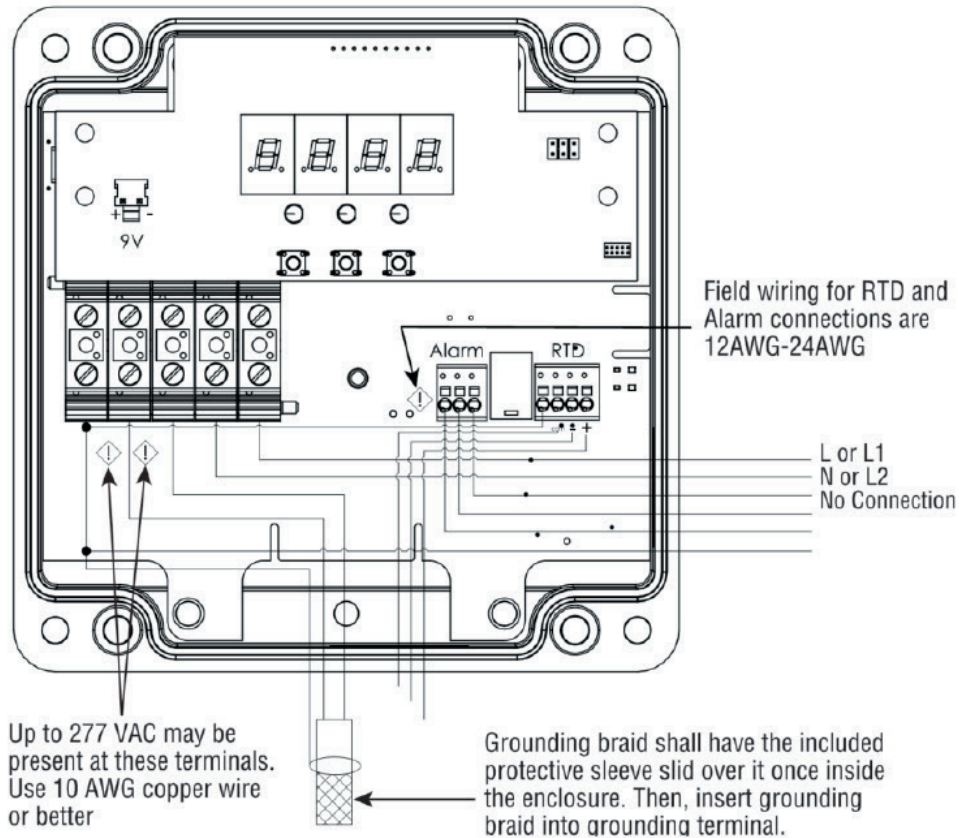

⚠ DANGER/DANGER

Hazardous voltage enclosed. Contact will cause electric shock and burn. Do not operate thermostat if lid is cracked, broken or uneven with enclosure.

Tension dangereuse à l'intérieur. Tout contact peut provoquer une décharge électrique et des brûlures. Ne faites pas fonctionner le thermostat si le couvercle est fissuré, brisé ou inégal avec le boîtier.

⚠ CAUTION/MISE EN GARDE

UL/cUL compliance. RTD wires longer than 50ft (15m) are not UL/cUL compliant. RTD wire should be no more than 50ft (15m).

Conformité UL/cUL. Les fils RTD de plus de 15 m ne sont pas conformes aux normes UL/cUL. Les fils RTD ne doivent pas dépasser 15 m (50 pi).

⚠ CAUTION/MISE EN GARDE

Enclosure lid must be properly sealed prior to operating. Each of the screws are to be evenly tightened by hand with appropriate screw driv-

er ONLY until snug. It is recommended that the lid be secured to the torque specified in the installation manual. Overtightening or uneven tightening may cause the lid to break which would void all environmental approvals.

Le couvercle du boîtier doit être correctement scellé avant l'utilisation. Chacune des vis doit être serrée uniformément à la main avec un tournevis approprié **UNIQUEMENT jusqu'à ce qu'elle soit just assez serrée. Il est recommandé que le couvercle soit fixé au couple spécifié dans le manuel d'installation. Un serrage excessif ou inégal peut entraîner la rupture du couvercle, ce qui annulerait toutes les approbations environnementales et de localisation dangereuse.**

⚠ CAUTION/MISE EN GARDE

EQUIPMENT DAMAGE. Equipment may not operate properly if not installed correctly. Install this device vertically.

Domages à l'équipement. L'équipement pourrait ne pas fonctionner correctement s'il n'est pas installé correctement. Installez cet appareil à la verticale.

 **CAUTION/MISE EN GARDE**

EQUIPMENT DAMAGE. Do not engage the Auto Cycle feature during normal operation. The heating cables will become fully energized for approximately 2 minutes throughout the Auto Cycle Interval which could cause damaging temperature overshoot.

Domages à l'équipement. N'engagez pas la fonction de cycle automatique pendant le fonctionnement normal. Les câbles chauffants seront entièrement sous tension pendant environ 2 minutes au cours de l'intervalle de cycle automatique, ce qui pourrait provoquer un dépassement de température nuisible.

 **CAUTION/MISE EN GARDE**

An arc flash label is provided. Data for this should be determined using a site arc flash study. The completed label should be affixed to the outside of the equipment.

Une étiquette d'éclair d'arc est fournie. Les données de cette étiquette doivent être déterminées à l'aide d'une étude d'éclair d'arc sur le site. L'étiquette remplie doit être apposée à l'extérieur de l'équipement.

 **NOTICE/AVIS**

De-energize all equipment before opening junction boxes and control panels and follow the appropriate lockout/tagout procedures. Do not work on live circuits. All equipment must be effectively grounded [earthed] in accordance with all national and local regulations, codes, and standards. During any service work, please follow the proper electrical isolation and lockout/tagout procedures.

Mettez tous les équipements hors tension avant d'ouvrir les boîtes de jonction et les panneaux de commande et suivez les procédures de verrouillage et d'étiquetage appropriées. Ne travaillez pas sur des circuits sous tension. Tous les équipements doivent être mis à la terre conformément à l'ensemble des réglementations, codes et normes nationaux et locaux. Lors de toute intervention, veuillez suivre les procédures d'isolation électrique et de verrouillage/déconnexion appropriées.

 **NOTICE/AVIS**

Users should install adequate controls and safety devices with their electric heating equipment. Where the consequences of failure may be severe, back-up controls are recommended.

Les utilisateurs doivent installer des contrôles et des dispositifs de sécurité adéquats avec leur équipement de chauffage électrique. Lorsque les conséquences d'une défaillance peuvent être graves, il est recommandé d'installer des commandes de secours.

 **NOTICE/AVIS**

A disconnect device and protection device(s) should be provided in the installation.

Un ou plusieurs dispositifs de déconnexion ou de protection doivent être prévus dans l'installation.

 **NOTICE/AVIS**

The equipment must be installed with a 2-pole isolating device when this equipment is connected to a supply where both wires/terminals are live.

L'équipement doit être installé avec un dispositif d'isolation bipolaire lorsqu'il est connecté à une alimentation où les deux fils/bornes sont sous tension.

 **NOTICE/AVIS**

Tighten or replace all loose or missing hardware.

Resserrez ou remplacez toute ferrure desserrée ou manquante.

 **NOTICE/AVIS**

Refer to the Chromalox unit design drawing for specific certifications(s) and/or classification rating. Certified enclosures **MUST NOT** be modified, altered, or repaired by anyone other than the manufacturer. Improper usage will void the warranty and could create a dangerous environment.

Reportez-vous au dessin de conception de l'unité Chromalox pour les certifications particulières et/ou la classification. Les boîtiers certifiés **NE DOIVENT PAS** être modifiés, altérés ou réparés par une personne autre que le fabricant. Une utilisation inappropriée annule la garantie et peut créer un environnement dangereux.

Start-Up

WARNING

For up to 30 amp loads, use minimum 10 AWG wiring or better for 120/277 VAC power input.

Connecting power to the unit.

1. Powering up with 120/277 VAC: To power up the unit apply 120/277 VAC to the terminal block according to the schematic below:

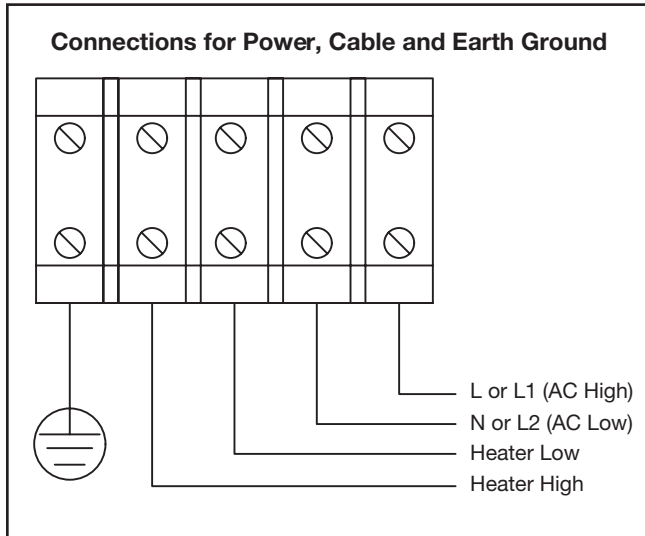

2. Programming with 9VDC battery:

The CET-GF may be programmed with a 9VDC battery should standard service line voltage be unavailable.

Note: Powering unit with 9VDC should only be used for programming purposes and not operation of the unit.

WARNING

3. Programming and alarm overview

Digital Thermostat must have the following components set to correctly control the temperature:

- a. Setpoint – targeted temperature value that controller will aim to reach
- b. Hi Temperature Alarm – Temperature at which the unit goes into high temperature alarm mode.
- c. Lo Temperature Alarm – Temperature at which the unit goes into low temperature alarm mode. Alarm can also be disabled by decreasing the value to a setting below (20°F)
- d. Deadband – The allowable temperature differential between the Set Point and the Sensed Temperature during normal operation. The Deadband is centered on the Setpoint. The Deadband has a range of 2 to 10 deg. in 2 degree increments.
The Load is removed once the temperature is 1/2 way between the Setpoint and the upper limit of the Deadband.
- e. Temperature Units – selection between degrees Fahrenheit or Celsius.
- f. Alarm State – NC (Normally Closed) or NO (Normally Open) contacts available.

Connecting RTD Wire

1. Connect RTD wire according to the schematic:

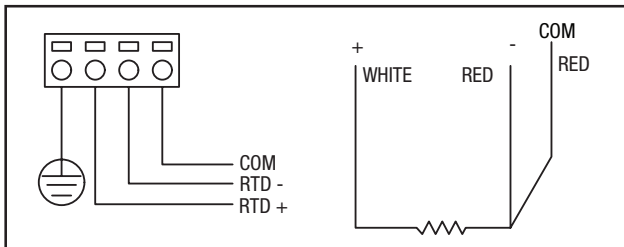

Alarm Wiring

The alarm on the CET-GF unit is an electromagnetic mechanical relay. The alarm relay is a dry contact and will need separate AC or DC voltage supplied. See page 15 for alarm contact ratings.

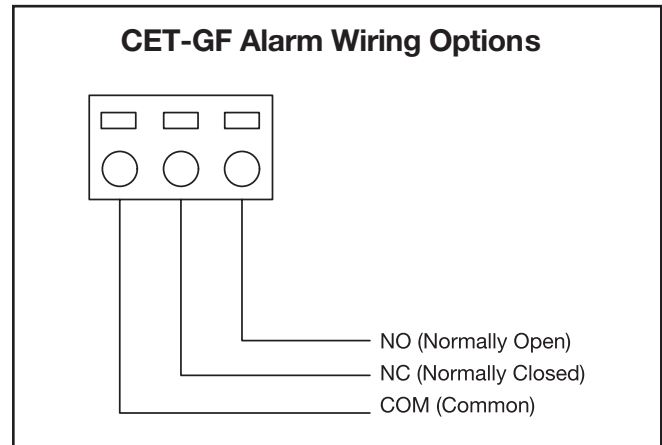

Programming

To program the digital Thermostat follow the instructions below:

Parameter	Display	Default	Min.	Max	Alternate
Set point	57P7	40°F (4°C)	32°F (0°C)	200°F (93°C)	
High Temp	H17P	150°F (65°C)	32°F (0°C)	230°F (110°C)	
Low Temp	L07P	32°F (0°C)	20°F (-6°C)	75°F (24°C)	Disabled/Off
Dead Band	88ND	4°F (2.5°C)	2°F (2°C)	10°F (6°C)	
Temp Units	UN17	°F	°F	°C	
Ground Fault	GFEP	30mA	30mA or OFF	150mA	
Trip*	7F1P	TRUE	TRUE	FALSE	
Latch*	L7CH	TRUE	TRUE	FALSE	

- Trip=TRUE and Latch=TRUE.
 - * Heat is turned OFF and remains off until the user intervenes.
 - * Alarm output goes to TRUE and remains TRUE until the user intervenes.
- Trip= TRUE and Latch =FALSE.
 - * Heat is turned OFF. Should the ground fault condition clear after that, the CET-GF would then go back to normal operation, switching the heat according to temperature setting.
 - * Alarm output goes to TRUE. Should the ground fault condition clear after that, the alarm would then go to FALSE.
- Trip=FALSE and Latch =TRUE.
 - * Heat continues to be switched according to temperature control setting, regardless of whether a ground fault is detected.
 - * Alarm output goes to TRUE and remains TRUE until the user intervenes.
- Trip=FALSE and Latch =FALSE.
 - * Heat remains ON (assuming that sensed temperature is cooler than setpoint), regardless of whether a ground fault is detected.
 - * Alarm output goes to TRUE. Should the ground fault condition clear after that, the alarm signaling output would go back to FALSE.

Resetting GFEP alarm (only when latch value is TRUE):

- Do not remove internal cover with power on
 - Do not use tools to reset alarm only use hands
 - Use caution when opening CET-GF when moisture is present due to internals being live
- * To un-latch GFEP alarm, one needs to set LATCH option to NO.

Troubleshooting

Alarm Type	Display	Solution
Sensor Open	Sens err	Check if your sensor is correctly connected to the unit
Sensor Shorted	Sens err	Check if your sensor is correctly connected to the unit
Lo Temperature	Blinking between sensed temperature and “LoTP”	Sensed temperature is below Lo Temp. Threshold. Alarm will be cleared automatically when sens temp > lo threshold + 5 deg
Hi Temperature	Blinking between sensed temperature and “HiTP”	Sensed temperature is above HI Temp. Threshold. Alarm will be cleared automatically when sens temp < hi threshold - 5 deg
EPR	Non-Volatile memory error	Press UP & DOWN keys for 2 seconds. Unit will be loaded with default settings
ERR1	Program memory error	Program memory corrupt. Solution: Reprogram the unit. Consult Factory.
GFEP	Ground Fault Alarm	Current leakage to ground. Inspect load wiring.
COM	Communication Error	Issue with temperature sensing clip.

Optional Wall Mount Kit

The CET-GF may be mounted on vertical surfaces. .

Considerations:

1. The kit comes complete with two stainless steel mounting brackets and the necessary hardware to mount the brackets to the CET-GF.
2. When installing the CET-GF on a vertical surface, the Pipe Standoff is not used and is typically replaced by rigid 1" NPT conduit. The conduit shall terminate into the Compression Fitting.

Ordering Information:

Wall Mount Kit PCN (Part Number): 514220

Stainless Steel Hardware:

Screw x 4 

Hex Nut x 4 

Washer x 4 

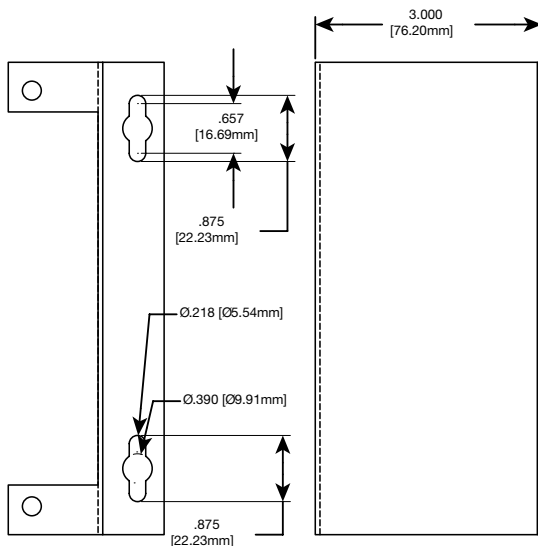
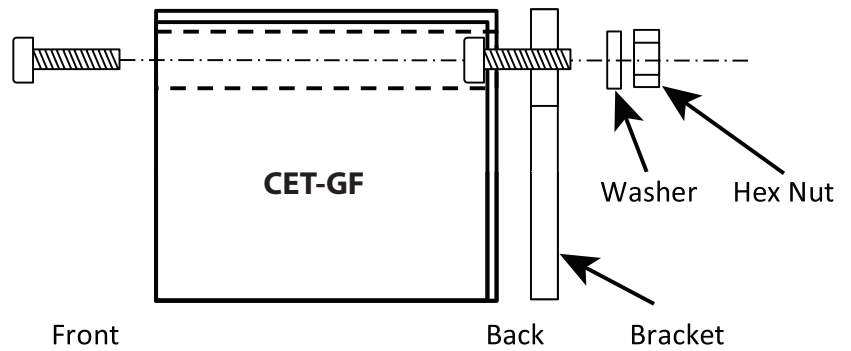

RECOMMENDED - WALL MOUNT LAYOUT MAXIMUM #10 STUD

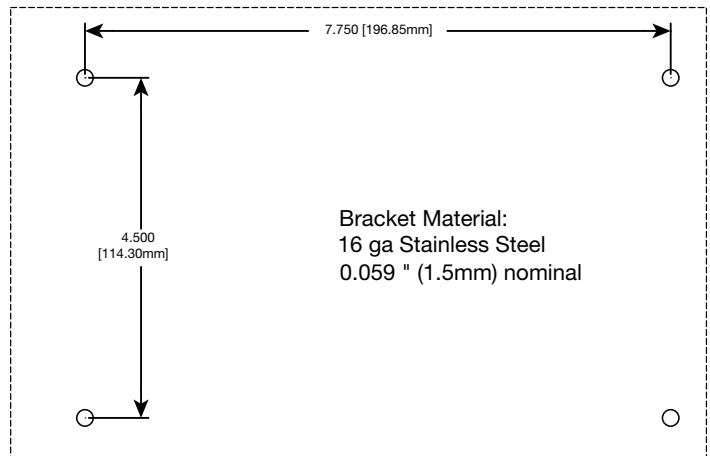

Product Maintenance & Care

The following inspections should occur upon receipt of product and at least once every year.

- a. Wiring
Inspect wiring for wear, fraying and evidence of overheating. Replace if needed.
- b. Hardware & Connectors
Inspect for loose electrical and mechanical connections. Tighten or replace all loose or missing hardware.
- c. Cleaning
Ensure the display is clean and visible. The heat sink fins on the back must be free from corrosion and debris. Remove all debris from the heat sink. If any of the fins are found to be broken then replace the unit.

Equipment Ratings:

Voltage Rating: 120-277 VAC, Overvoltage Category II 50/60 Hz

Current Rating: 30 amps

Ambient Temp. Rating: -40°F to 104°F (-40°C to 40°C)

Alarm Rating:

- DC Contact Rating up to 2A, 30VDC Resistive
- AC Contact Rating up to 0.6A, 120VAC or 0.2A, 250VAC General Purpose

VA rating on electronics: 4.0 Watts

Maximum RTD output 1.25 volts, 7 milliamps

- Maximum RTD length (with extension wire) 50ft

Group 1, Class A equipment per EN 61326-1:2013

Enclosure rating: Type 4X, IP67

Settings:

Setpoint: 32°F(0°C) to 200°F(93°C)

Alarms: High Temp: 32°F (0°C) to 230°F (110°C)
Low Temp: 20°F (-6°C) to 75°F (24°C);
or Disabled/Off

Deadband: 2°F(2°C) to 10°F(6°C)
+/-1°F to 10°F around the setpoint

Alarm Function:

Mode	COM-NC	COM-NO
Normal Operation	Open	Closed
Alarm Condition	Closed	Open
Power Off	Closed	Open

Agency Approvals:

UL:

- UL/cUL
- UL File number QUXX.E84610
- cUL File number QUXX7.E84610

CE

Field Wiring Considerations:

Torque values for field wiring terminals.....11-15 in-lbs
(1.2 - 1.7 n-m)

Main Cable Load Wire Gauge Range.....6-18 AWG

Field Wiring for RTD and Alarm Conn.12-24 AWG

Stripped insertion length..... 1/2" (12mm)

Limited Warranty:

Please refer to the Chromalox limited warranty applicable to this product at
<http://www.chromalox.com/customer-service/policies/termsofsale.aspx>.

Chromalox
103 Gamma Drive
Pittsburgh, PA 15238
(412) 967-3800
www.chromalox.com